

# MANUAL

Batterie - Motor-Controller  
BAMO A1, A2-x-60 ... 500  
for DC-Motors



Industrie Elektronik  
G m b H

Hans-Paul-Kaysser-Strasse 1  
D-71397 Leutenbach 3 - Nellmersbach

Tel.: 07195/9283-0  
Fax 07195/928329  
email [info@unitek-online.de](mailto:info@unitek-online.de)  
Http// [www.unitek-online.de](http://www.unitek-online.de)

Ausgabe  
1108-1

<b>Contents</b>		<b>Page</b>
<b>1</b>	<b>Basic Information</b>	
	Safety Advice	3
	General Information	4
	Application	4
	Construction	4
	Technical Data	5
<b>2</b>	<b>Mechanical Installation</b>	
	Dimensions 60, 120, 240	6
	Dimensions 280	7
	Dimensions add. Heatsink 60 ... 240	8
	Dimensions add. Heatsink 280	9
<b>3</b>	<b>Electrical Installation</b>	
	Connection Overview	10
	Power connections	11
	Control connections	12
	Speed-command value	13
	External current limit	14
	ready for operation (BTB) indication	15
	Analogue measuring outputs	15
	Plug-Clamp Numbers	16
<b>4</b>	<b>Device Overview</b>	
	Component overview	17
	Blockdiagram	18
	Adjustment functions	19
<b>5</b>	<b>Adjustment</b>	
	Adjustment advice	20
	Speed - command value	21
	Speed - actual value	22
	Current limitation	23
	Speed controller switching	24
	Adjustment without measuring instruments	24
<b>6</b>	<b>Getting Started</b>	
	Default setup	26
	First getting started	27
<b>7</b>	<b>Fault Finding</b>	
	Functions errors	28
	Signals	29
<b>8</b>	<b>Protocol</b>	30
<b>9</b>	<b>Guarantee</b>	31

Electronic devices always involve the risk of failure.

## **Caution Direct Voltage** **DC 160V=**



This manual has to be read carefully and must be understood by experts before installing or starting the device.

If there are any doubts call your trader or the manufacturer.

The BAMO series is designed to regulate electrical currents;  
protection standard IP00.

Connection only to a battery or galvanic isolated direct voltage. (See Page 10)

### **Standards and Guidelines:**

The device and it's associated components can only be installed and switched on where the local laws and technical standards have been strictly adhered to:

- |  |  |
|--|--|
| EU-Guidelines  | 89/392/EWG, 84/528/EWG, 86/663/EWG, 72/23/EWG<br>EN60204, EN50178, EN60439-1, EN60146, EN61800-3 |
| - IEC/UL   | IEC364, IEC 664, UL508C, UL840   |
| - VDE-regulations                                      | VDE100, VDE110, VDE160   |
| - TÜV-regulations                                      |  |
| - Regulations of Professional and Occupational bodies: | VGB4   |

The user has to assure that: after

- a failure of the device
- an incorrect handling
- a failure of the control unit etc.

the drive is brought to a secure operating condition.

Machines and installations are to be provided with supervisory and safety equipment, that is independent of the device.

### **Adjustment**

- only by qualified personnel
- adhere to safety regulations

### **Installation work**

- only when disconnected from all power lines.

### **QS**

The devices are archived by the manufacturer with serial number and their test specifications.

### **CE**

The EU-guide line 89/336/EWG with the Regulations EN61000-2 and EN61000-4 are observed.

## General Information

The battery motor controller BAMO-Ax-xx forms together with the low voltage DC-motor a propulsion unit distinguished by its high control range.

With a DC-motor the current is proportional to the torque and the voltage is proportional to the speed.

Current and voltage are measured precisely.

The analogue circuits of the servo drive are simply constructed.

The speed actual value is generated from armature voltage or from the DC-tachogenerator.

The speed and the current controller are designed as P-I-controller.

In version BAMO-A2 (4Q) the brake energy is refeeded to the battery.

## Application

for all kinds of machines or vehicles up to 40kW battery feded drive power especially for

- a great controller range
- a high efficiency
- small motor dimensions
- a even and smooth travel

for speed or torque regulation or

combined speed-torque regulation with or without superposed position controller.

## For use in

battery powered vehicles like cleaning machines, el. boats, fork-lift trucks, transport systems, Solar- or wind powered installations, and many other battery powered machines and installations.

## Construction:

Cubicle-mount unit in IP00 according to the VDE- DIN- and EU- regulations.

Standard analogue regulation electronics.

Power electronics with IGBT-power semiconductors, generous dimensioning.

## Characteristics:

- \* Battery supply or galvanic isolated direct voltage (Notice advice on page 10 !)
- \* Galvanic isolation between auxiliary voltage and regulation electronics  
auxiliary voltage and power stage  
regulation electronics and power stage
- \* Differential command value inputs
- \* Speed and torque regulation
- \* Static and dynamic current limit
- \* Measuring outputs for speed and current
- \* Enable logic, quick stop
- \* Temperature control for motor and device

## Technical Data

### Power Connection

Type <b>BAMO A1, A2</b>	<b>36 - 60 ... 360</b>	<b>160 - 60 ... 360</b>
Battery voltage	12, 24V	36 up to 160V
Direct voltage bus	12, 24V	36 up to 160V
Output voltage $0.8 \times U_B$	max.30V	max. 150V
Auxiliary voltage		
	24V= $\pm 20\%$ , max. 0.5A, waviness <20%	

### Spezifications

Type <b>BAMO A1, A2 -x-</b>		<b>60</b>	<b>120</b>	<b>180</b>	<b>280</b>	<b>360</b>
Steady current max.	A=	60	120	180	280	360
Peek current max. (5s)	A=	100	200	300	400	600
El. power max	kW	7.8	15.6	23.4	36.4	46.8
Power dissipation	W	300	600	900	1400	1800
External fusing	A	80	160	300	500	600
Cooling	See cooling advice page 8					
Dimensions (see drawings)	Size	2				3
Weight	Kg	6				11

### Common specifications

Protection standard	IP 00
Device layout	VDE 0100 group C VDE 0160
Humidity stress	class F accordig to DIN 40040 no dewing
Set up height	< 1000m above NN
Operation range	0 ... 45°C
Extended operation range	up to 60°C red. 2%/°C
Bearing range	-30°C up to + 80°C
Speed controller	
control accuracy	without actual value error $\pm 0,5\%$
Control range	1: ,000
Temperature observation	80°C

**VERSIONS:** BAMO A1-xx 1 Quadrant-controller propeling in rotation direction  
 BAMO A2-xx 4 Quadrant-controller propeling and breaking in both rotation directions. Energy rear feed

**CAUTION:** for battery operation or direct current bus only  
 (see advice on page 10)



# BAMO A1, A2 60-500A

Dimensions

## Dimensions BAMO A1,A2-x-60,120,240

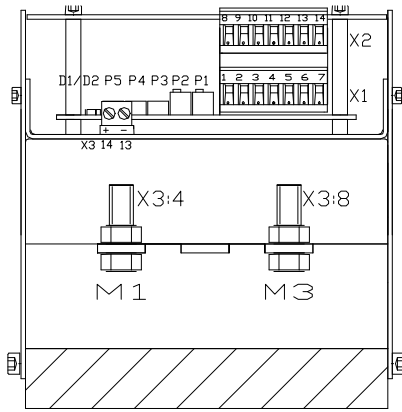

Mounting plate or additional head sink .

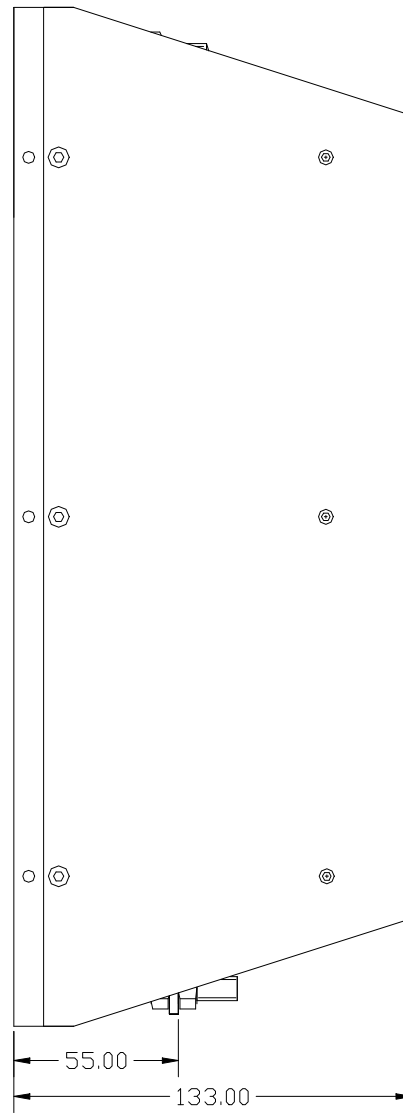
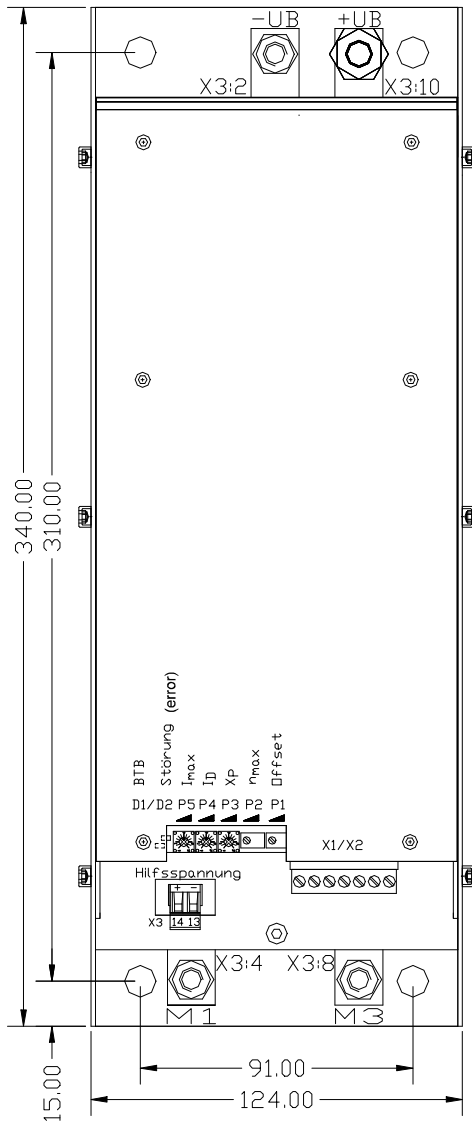

Size 2

# 2 Mechanical installation

## Dimensions BAMO A1, A2-x-280, (500)

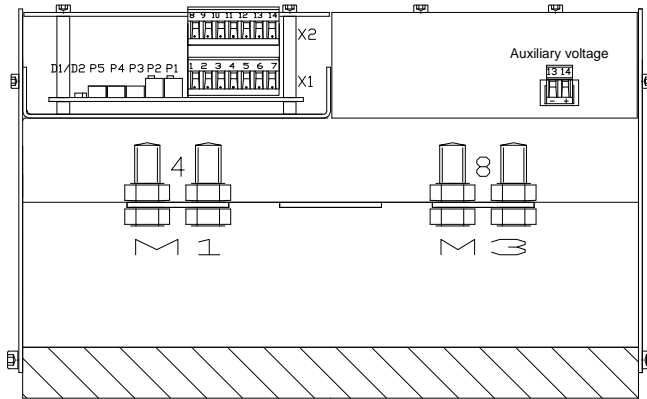

Mounting plate or additional head sink.

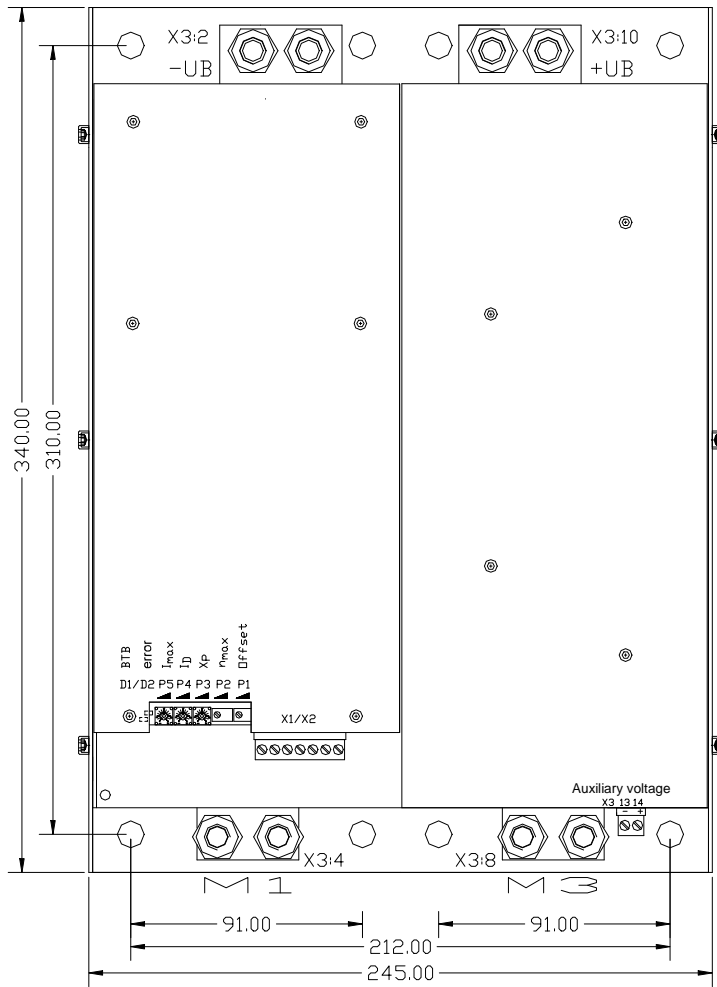

Size 3

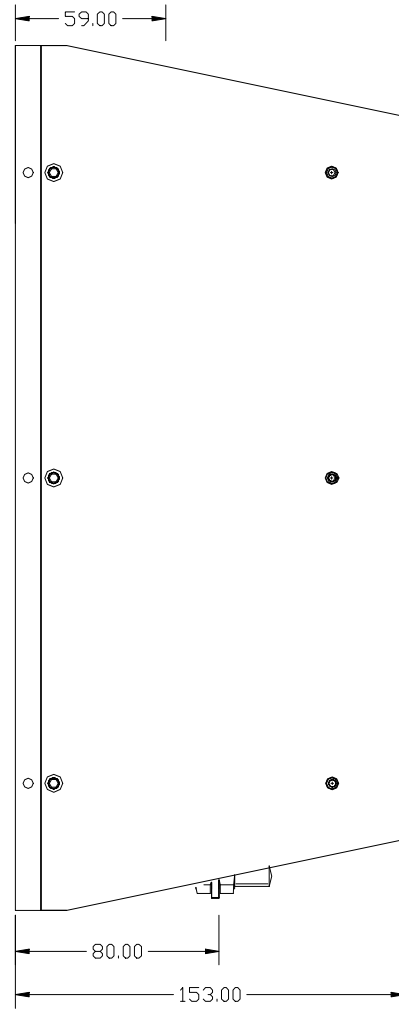

Additional heat sink type LUKUE - 3,4 (mountig on the BAMO)

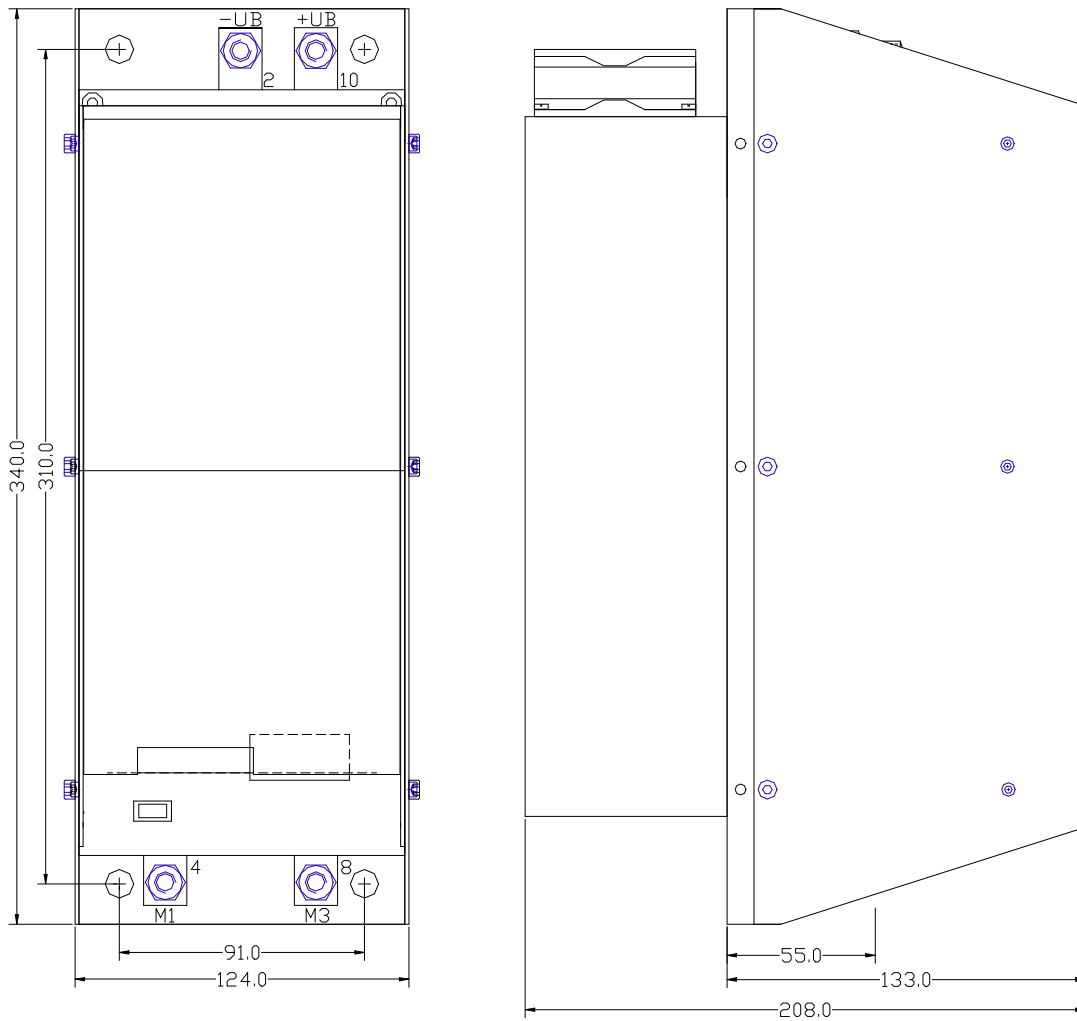

Size 2	1x addit. heat sink LUKUE 3	(Weight + 3kg)
Size 3	1x addit. heat sink LUKUE 4 or 2x LUKUE 3	(Weight + 6kg)

Screws M10x110mm



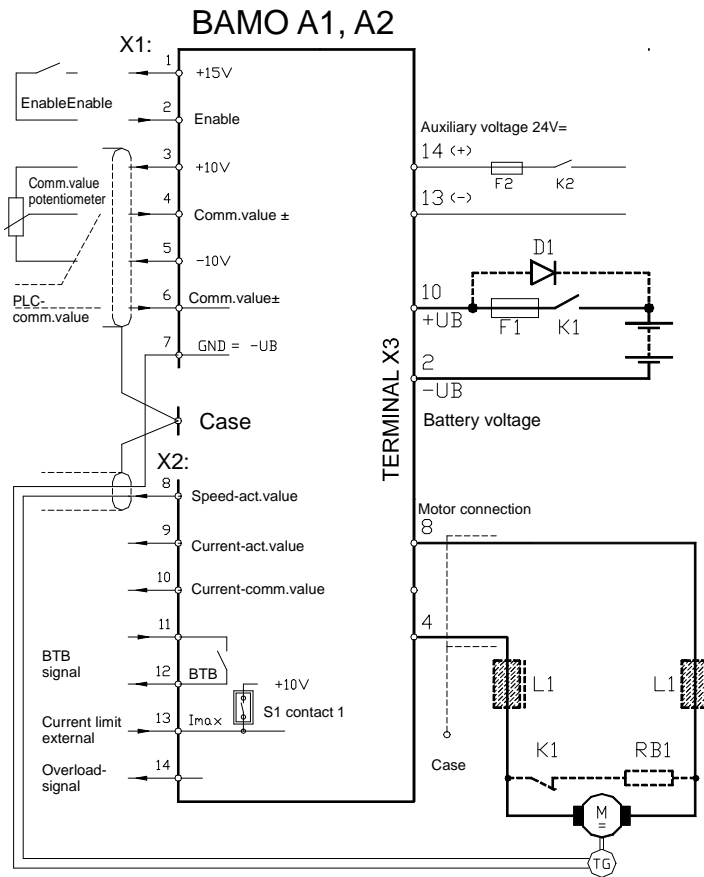

**Notice:**

**Power connection X3:2 (-UB) , X3:10 (+UB)**

Connection polarity > no protection against mixing up the contacts  
when the connection is wrong the output stage can be destroyed!

The power connection must not be devided during braking! If nessesary built in reverse-current-protection-diode D1. On-stage current = device peek current

**Connection to Direct voltage bus or Power supply unit**

Make sure that the overvoltage in the buffer circuit is limited to 20% during braking. Small resistance of the source or ballast circuit. If the resistance of the motor is very small the fast rising of the buffer voltage circuit can damage the semi-conductors. In normal case the device is switched to error by the overvoltage observation.

**Auxiliary voltage connection X3:13, X3:14**

Safe against mixing up the contacts. The connection can be switched seperated from the power connection. Notice the tolerance and the residual ripple of the voltage.

**Motor connection X3:4 (M1),X3:8 (M3)**

The motor connections can be exchanged. In case of EMC-problems use chokes and shielded line. Brakong resistor RB1 and DC-contactor K1 as resistor brake with type A1 or as battery failure brake with type A2

**Control connections see special advices.**

# 3 Electrical installation

## Power Connection

### Caution:

The connection advices concerning the individual attachment of the connections to the plug numbers or terminals are binding.  
All further advices to this are not binding.  
The input and output lines can be altered or completed in consideration of the electrical regulations.

### Notice:

- connection and operation advices
- local technical regulations
- EU-machine regulation 89/392/EWG, 84/528/EWG, 86/663/EWG
- CE-advice, EMC

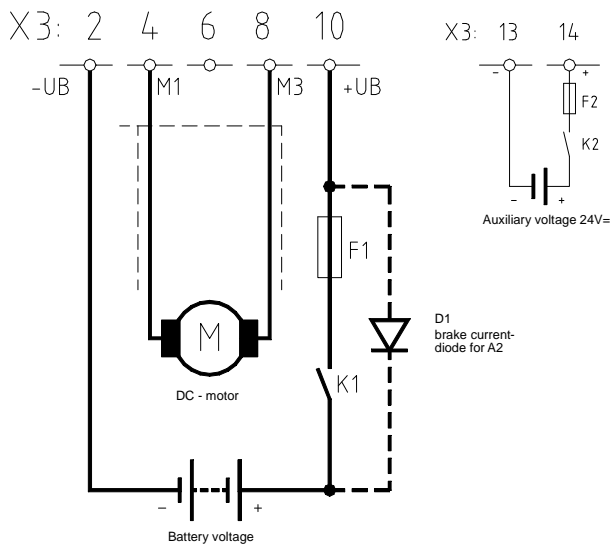

### Caution: Risk of destruction by overvoltage in buffer circuit

Using BAMO-A2-36 the battery voltage ( $U_{B+}$  X3:10,  $U_{B-}$  X3:2) must be applied to the device 10s before switching on and 10s after switching off enable to limit a possible occurring brake voltage by the battery reverse current protection diode D1 against uncontrolled disconnecting the battery voltage while braking.

If using a DC-Bus notice advices on page 10.

Dimensioning	at A	60	120	240	280
Battery lines (max. 2m)	mm <sup>2</sup>	10	35	95	120
Motor lines	mm <sup>2</sup>	10	35	95	120
Fuse F1	A	89	160	360	500
Auxiliary voltage line	mm <sup>2</sup>	0.5			
Fuse F2	A	2A			

### Connection lines

**Caution :** with longer lines >>> use a one step stronger cross section !

## Control Connection

The connecting advices are for general information and without obligation

### Notice:

- Connecting- and operating instructions
- Local regulations
- EU-machine regulation



pin-No. terminal block

X1: 1 up to X1:7 and X2 : 8 up to X2 : 14

### Signal lines

- Shielded and seperated from power lines.
- command values paired twisted and shielded.

### Logical connections

- Relay with gold contacts or reed relays. Contact current 6mA.

### Enable -internal logical voltage

- internal logical voltage X1:1 +15V/10mA
- contact chain between X1:1 and X1:2

### Enable -external logical voltage

- enable voltage +10 ... +30V X1:2
- GND X1:7

### Switch on enable

- command value and speed controller are enabled immediately.

### Switch off enable

- command value and speed controller are enabled stop
- command value >>> is switched internally immediately to 0
- after 2 seconds >>> speed controller is locked.

### Caution:

Make sure that the battery voltage is connected to the device at least for 10 seconds after switching off the enable.

### Auxiliary voltage connection

- Direct voltage command 24V=
- Operating range 19V up to 54V=
- Rated current 0.5A, inrush current 2A
- Residual ripple <20%
- Fusing 2AF

**Caution:** when using a switching power supply for auxiliary voltage.  
Switch on power supply before connecting auxiliary voltage (K2).

# 3 Electrical installation

## Command value-speed

voltage source for command values  $\pm 10V$ , 10mA

+10V	X1:3
-10V	X1:5
GND	X1:7

## Command value input

- command value input maximum  $\pm 10V$
- differential input
- input resistance 50 k $\Omega$
- relay contacts: gold- or reed contacts



## Caution

command value lines paired twisted and shielded. Screen connection one-sided.

## Connection:

### Command value voltage with internal supply

command value	X1:4 (signal)
	X1:7 (GND)
bridge	X1:6 — X1:7

### External command value voltage SPS/CNC

command value	X1:4 (signal)
	X1:6 (GND)

### External command value current SPS/CNC

Resistance for command value current 0 ...  $\pm 20mA$  >>> R-comm. = 500 $\Omega$

command value current	X1:4 (signal)
	X1:6 (GND)

Int.supply

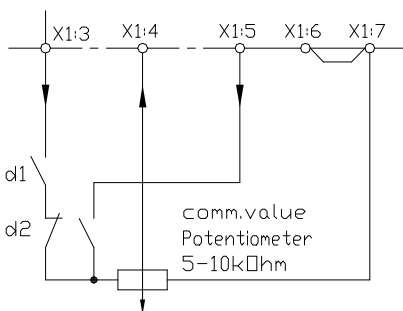

CNC/PLC

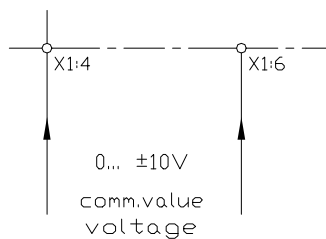

Comm.value current

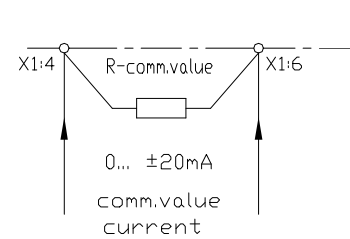

With **A1(1Q)** only positive command value  
leave out d2 and connection X1:5 is not coated

## Caution:

do not use a command value current between 4 and 20mA



**External current limitation**

voltage source for external current limit

+10V/10mA X1:13  
 GND X1:7

**Current limit input**

maximum input voltage +10V  
 input resistance 10 kΩ  
 internal attenuation with potentiometer I<sub>max</sub>  
 relay contacts: gold- or reed contacts  
 switch S1, contact 2 = OFF (see page 17)

**Connection**

current limit X2:13 (signal)  
 X1:7 (GND)

**Adjustment range**

0 ... +5V >>> 0 up to 100% device command current  
 0 ... +10V >>> 0 up to 200% device command current  
 internal overcurrent control >>> max. 5sec.

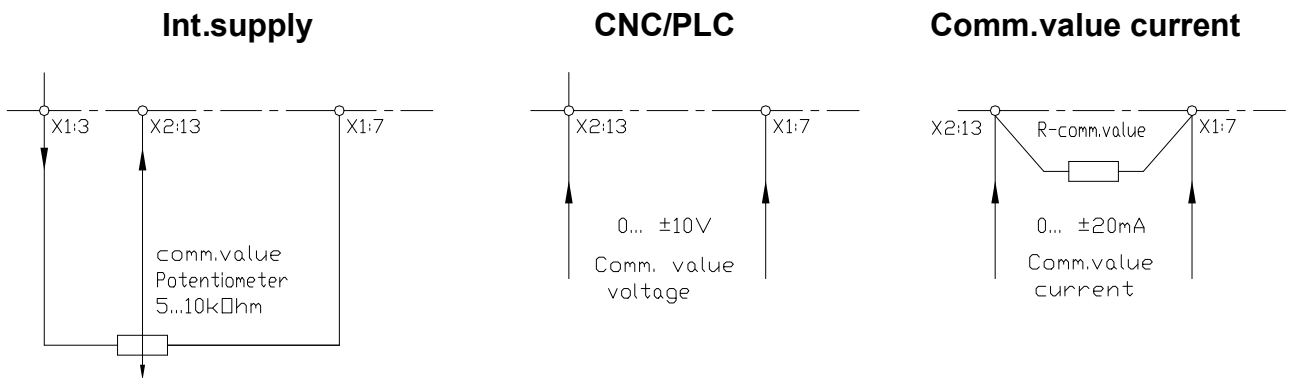

**Caution:**

case of internal current limit adjustment  
 switch S1 >>> contact 2 = ON  
 (see page 19)



# 3 Electrical installation

## Ready for operation signal BTB

### Relay

signal contact X2:12 - X2:13  
contact values max. 48V; 0,5A

The ready for operation signal (BTB) shows the CNC/PLC that the drive is ready for operation.  
Switch BTB- signals of several axes in one row.

delay after switching on mains >>> max. 1sec.

Function	Indication	BTB-Relay
Ready for operation	LED bright green	Contact closed
Not ready for operation	LED glims green	Contact open
Error	LED bright red	Contact open

BTB turns off with	Error is
Overtemperature	not stored
Overvoltage	stored
Short, Line-to-earth-fault	stored
Voltage error	not stored

To reset store switch off/on enable

### Caution:

Use BTB-contact always with CNC/PLC - control or with emergency-stop circuit !  
Self-starting possible!  
Fault memory is not effective with all faults !



### “Blocked” Indication

Current demand	Output X2:14
Normal	> +10V
Overload	< +2V

### Analogue measuring outputs

Function	Motor current display	Speed display
Connection	X2:9 , X1:7	X2:8 , X1:7
Value peek current	+5.0V	
Value steady current	+2.5V	

**Control connections**

Function	Designation	Clamp-Number
Voltage 15V/10mA	Enable - supply	X1:1
Enable +10 bis +30V=	Enable - input	X1:2
Voltage +10V/10mA	Comm.value - supply +	X1:3
command value +	Comm.value - input +	X1:4
Spannung -10V/10mA	Comm.value - supply -	X1:5
command value -	Comm.value - input -	X1:6
GND		X1:7
Speed actual value	Tacho connection	X2:8
Current actual value	Measuring output	X2:9
Current command value	Measuring output	X2:10
BTB - contact	Ready for operation	X2:11
BTB - contact	Ready for operation	X2:12
Current limit external	Current limit input	X2:13
Blocked	Output	X2:14

**Power connections**

Function	Designation	Bolt-/Clamp-Number
Battery -	-UB	X3:2
Motor 1	M1	X3:4
Motor 3	M3	X3:8
Battery +	+UB	X3:10

**Auxiliary voltage connection**

		Clamp-Number
GND-24V		X3:13
+24V=		X3:14

# 4 Device overview

## Component overview

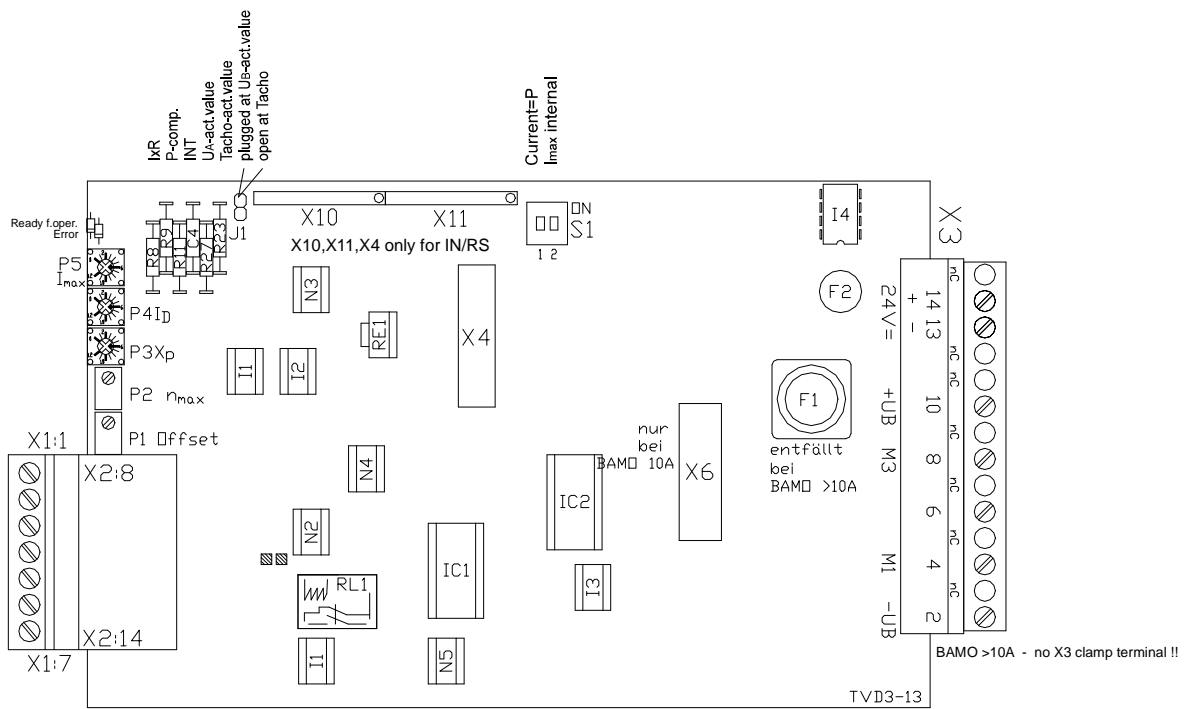

Indication	Function
D1 green	ready for operation
D2 red	Error
<b>Trimmer</b>	
P5	$I_{max}$
P4	$I_D$
P3	$X_P$
P2	$n_{max}$
P1	Offset

Clamp	Function
X1:1	+15V
X1:2	Enable
X1:3	+10V
X1:4	comm. value + (-)
X1:5	-10V
X1:6	comm. value - (+)
X1:7	GND
X2:8	n-act. value
X2:9	l-act. value
X2:10	l-comm. value
X2:11-12	BTB- contact
X2:13	Ext.current limit
X2:14	blocked

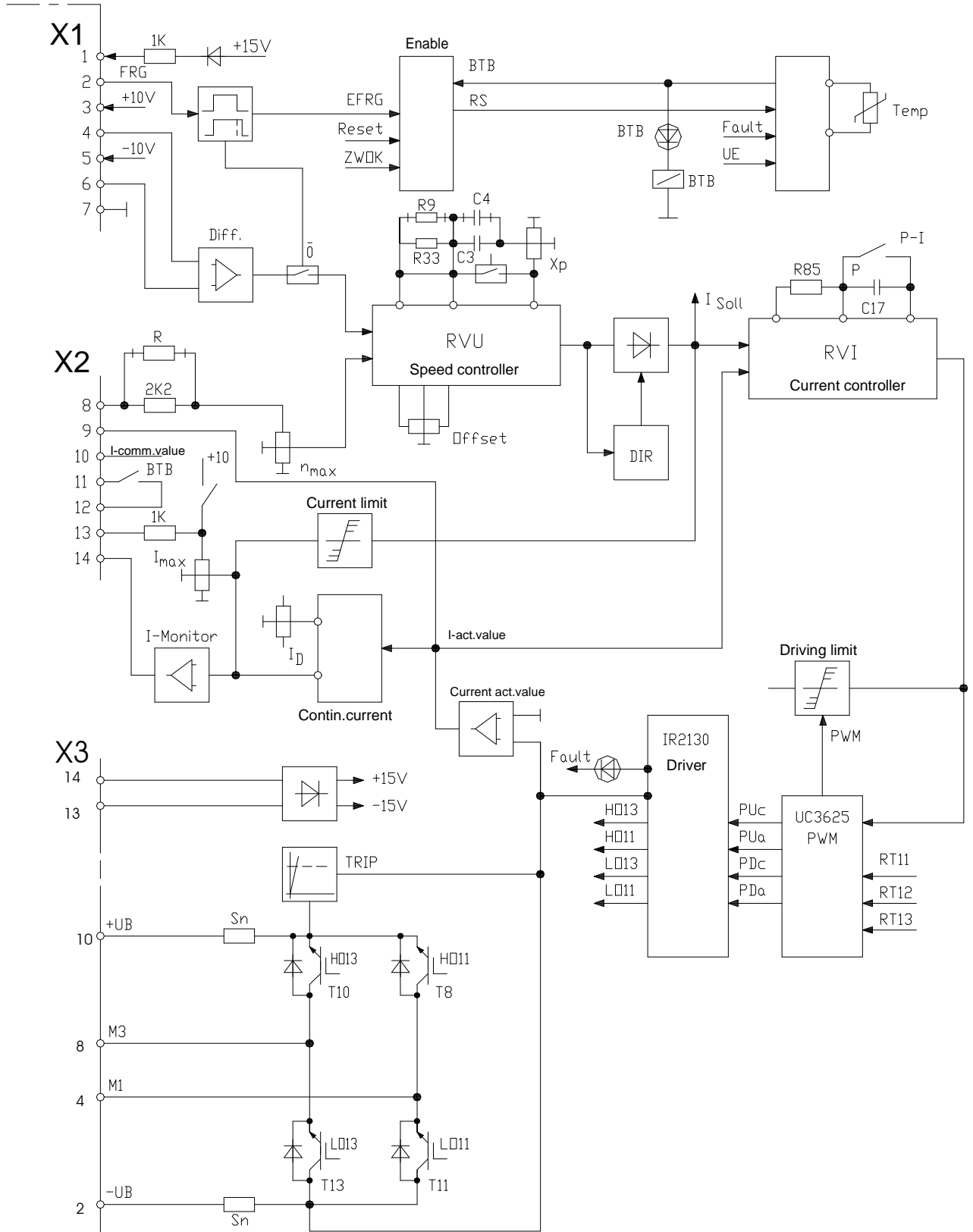

## Adjustment functions

Function	Trimmer	Switch	Jumper	Component
Act.value balance DC-Tacho	P2 ( $n_{max}$ )		J1 open	R3
Actual value balance armature voltage control	P2 ( $n_{max}$ )		J1 plugged	R27
IxR-compentation				R8
Internal Current limit	P5 ( $I_{max}$ )	S1-2 ON		
External Current Limit	P5 ( $I_{max}$ )	S1-2 OFF		
Steady current	P4 ( $I_D$ )			
Amplification P-Component	P3 ( $X_P$ )			R9
Amplification I-Component				C4
Integrator				R11
Null balance	P1 (Offset)			

## Switch S1

Function	Contact	ON	OFF	
Current limit	2	internal	external	
Current amplification	1	P	PI	

## LED-Indications

Function	Colour	Shines	LED No.	
Ready for operation (BTB)	green	bright	D1	
Temperature error	green	glim	D1	
Error	red	bright	D2	

## Signal outputs

Function	Designation	Clamp-number
Speed	n-actual value	X2:8
Current	I-actual value	X2:9
Current command value	I-comm.value	X2:10
blocked	+12V/10mA	X2:14
Ready for operation -contact	BTB/error	X2:11 , X2:12

## Adjustment Advice

### Adjustment

- only by qualified personnel
- adhered to safety regulations
- notice adjusting sequence

Presettings	Adjust with
Actual value	Tacho coarse adjustment R23
Internal/external current limit	Switch S1, contact 2
Current regulator P- PI	Switch S1, contact 1

Optimization	Adjust with
Act.value adjustment	$n_{\max}$ adjustment
Current controller	Switch S1, contact 1 (default setup = ON)
Current limit	$I_{\max}$ , $I_D$ -adjustment
Speed controller	Xp-adjustment, variable components
Zero point	Offset adjustment
Path-/position controller	in CNC\PLC

### Caution:

control systems have to be optimized from inside to outside.

Sequence :

Current controller   determined by the load circuit time constants (motor circuit inductance and motor circuit resistance)

Speed controller    optimized in factory, changing P/PI-amplification with S1  
determined by the drive (inertial moment, frictional moment)  
optimize to dynamic of the drive

position controller   optimize in the control (CNC\PLC)

### Measuring values

Measuring value	max.value	Measuring point
command value	$\pm 10V$	X1:4
Speed act.value before divider	$\pm 150V$	X2:8
Current act.value unipolar	+ 5V	X2:9
Current comm.value unipolar	- 10V	X2:10

# 5 Adjustment

## Actual Value

Function	max.Value	Connection
Input Signal	$\pm 10V=$	X1:4
Input GND		X1:6

Differential Input >>> signal- and GND-connection exchangeable  
 External Supply >>> Bridge X1:6 and X1:7, GND connected to X1:7

### command value as current signal

comm.value from external current source                      0 up to  $\pm 20mA$   
 external burden resistor for comm. Value                      0 up to max.  $\pm 10V$

comm.value resistor  $R_{Soll}[\Omega] = \text{comm. value voltage} / \text{comm. value current}$

### Caution:

do not use comm. value current between 4 and 20mA  
 With A1x only positive command value



### Command value integrator

Linear-integrator  
 Integration time adjustment with resistor R11 (INT)

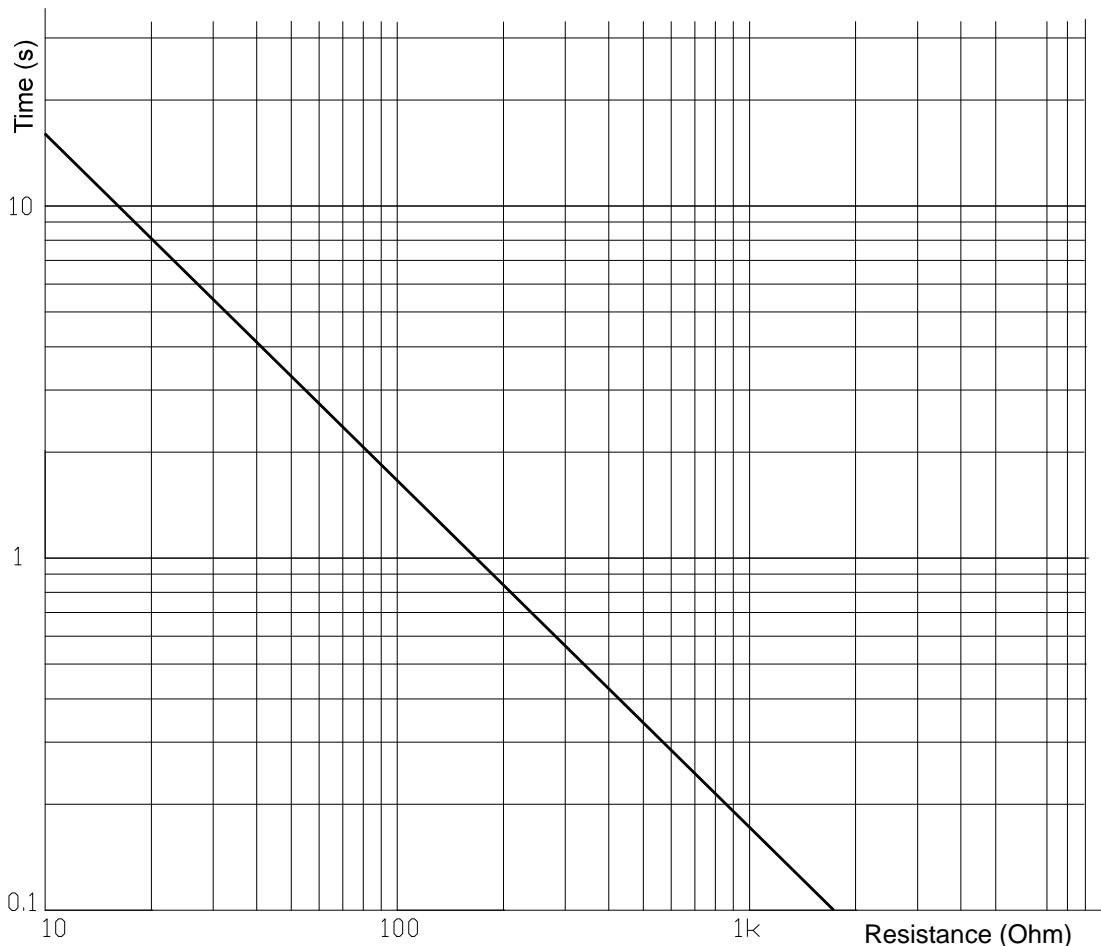

**Actual value - speed**

**BAMO-A1x (1Q) DC- or AC-tachogenerator with rectifier**  
**BAMO-A2x (4Q) only DC-tachogenerator**

**Tacho- Connection**

Jumper J1 open

Input X1:7 = tacho (GND )  
 Input X2: 8 = tacho ( Signal)  
 PE-Bolt = shielding

Command value input X1: 4 positive >>> tacho input X2: 8 positive

**Tacho voltage**

At maximum speed  
 limits >>> minimum 5V=, maximum 160V=

**Coarse adjustment**

with resistor R23

Tacho-voltage-range

Without R23 >>> 15V = up to 160V=  
 With R23 1kΩ >>> 5V = up to 55V=

**Armature voltage regulation with IxR -compensation**

Internal feed back , Jumper J1 plugged

coarse adjustment

voltage range resistor R27

IxR compensation

motor resistance resistor R8

**Speed fine adjustment**

With Potentiometer n<sub>max</sub> (P2)

command value from potentiometer:

with 1V comm. value adjust to 10% of maximum speed

with 10V comm. value fine adjust to 100% (max. speed)

command value from CNC\PLC:

with 0.8V comm. value adjust to 10% of maximum speed

**Changing direction of rotation**

change motor- **and** tacho-connection

with armature voltage regulation change only motor-connection.

# 5 Adjustment

## Current limitation

peak current            range 0 up to 200% command current    trimmer  $I_{max}$  (P5)  
 reset time max. 5sec.  
 steady current        range 5 up to 100% command current    trimmer  $I_D$  (P4)

### Internally resetting current limits

current limit	function	limit
overload	time	continuous current
signal to X2:14	blocked	

### Steady current

internal current limit (default setup)

adjustment	switch	trimmer
$I_{max}$	S1, contact 2=ON	$I_{max1}$ (P5)

external current limit

adjustment	input	switch	trimmer
$I_{max}$	X1:9 0 ... +10V	S1, contact 2=OFF	$I_{max1}$ (P5)

the external current limit can internally be reduced with  $I_{max}$ -potentiometer.

### Steady current

Motor protection. Adjust on motor command current with potentiometer  $I_D$  (P4).

### Measure adjusted values:

- do not connect motor
- predetermine command value and enable >>>            switch off/on

Measuring value	current command value	X2:10	(5V=command current)
command value	Measuring value $I_{max}$ (ca. 2sec.)		Measuring value $I_D$
+5V	0 up to max.10V		0.25 up to max. 5V
- 5V	0 up to max.10V		0.25 upto max. 5V

### Actual value

Measuring value	current actual value	X2:9
command value	Measuring value $I_{max}$ (ca. 2sec.)	Measuring value $I_D$
±	0 up to max. 5V	0.12 up to max. 2.5V

### Caution:

for exact torque control:  
 PI-current control switching necessary (default = P-current control)  
 -change from P to PI in current controller (switch S1,Contact1= OFF)



## Speed controller switching

- variable components R9, C4
- amplification potentiometer P3 (Xp)
- in case of changing devices >>> take over adjustment values.

## Defult Setup

Values of solded in components

P-component = 390kΩ decrease with R9 (47kΩ up to 220kΩ)

I-component = 22nF increase with C4 (0,1μF up to 1μF)

- amplification trimmer Xp to 50%

- optimal for most drives.

## Adjustment without measuring instruments

Connect motor,

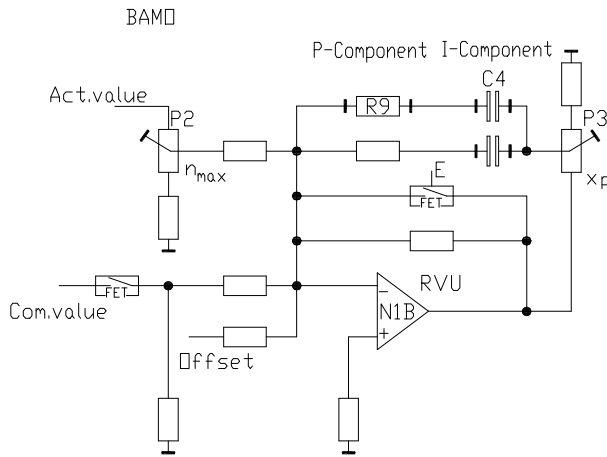

command value = 0

Xp = 50% (turning clock-wise increases amplification)

R,C = default values

Regler freigeben,

- Potentiometer Xp rechtsdrehen bis der Antrieb schwingt
- Potentiometer Xp linksdrehen bis die Schwingung abklingt,
- Xp-Poti noch 2 Stellungen weiter nach links drehen.

## Drive behaviour:

Amplification too low	Amplification too high
long oscillations 1... 0.1Hz	short oscillations 30 ... 200Hz
long overshoots	vibrates during acceleration,
overruns target position	vibrates during braking and in position

## Caution:

in case of operating with CNC\PLC

-in case of maximum speed

-adjust command value speed with Poti n<sub>max</sub> from 8 up to 9V



# 5 Adjustment

## Default setup

### Check connections before getting started

Connection	Voltage	Clamp	
Battery connection	Max. 36V or max.160V	X3:2	X3:10
Auxiliary voltage	24V= ± 20%	X3:13	X3:14
Motor connection	max. 30V or max. 150V	X3:4	X3:8

### NOTICE Technical data !!!

### Basic connections - power supply

Battery	2x power connection, <b>NOTICE POLARITY!</b>
Motor	2x Motor line

### Basic connections - control connections

Auxiliary voltage	24V= ± 20%	X3:13 , X3:14
Ready for operation (BTB)	Contact between	X2:11 , X2:12
Enable	Contact between	X1:1 und X1:2
Comm.value from PLC	Differential input ±10V	X1:4 , X1:6

Comm.value - internal supply with trimmer		Bridge X1:6-X1:7
A1 (1Q)	Positive 10V	X1:3 (GND X1:7)
A2 (4Q)	Positive 10V	X1:3
	Negative 10V	X1:5
Comm.value	± 10V	X1:4

Act.value tachometer	± 160V	X2:8 (GND X1:7)
----------------------	--------	-----------------

Armature voltage regulation no actual value connection. Jumper J1 plugged!

### Default setup for first getting started

Function	Potentiometer	Adjustment
Peek current	$I_{max}$	20%
Steady current	$I_D$	100%
Amplification	X <sub>P</sub>	10%
Speed	$n_{max}$	0%

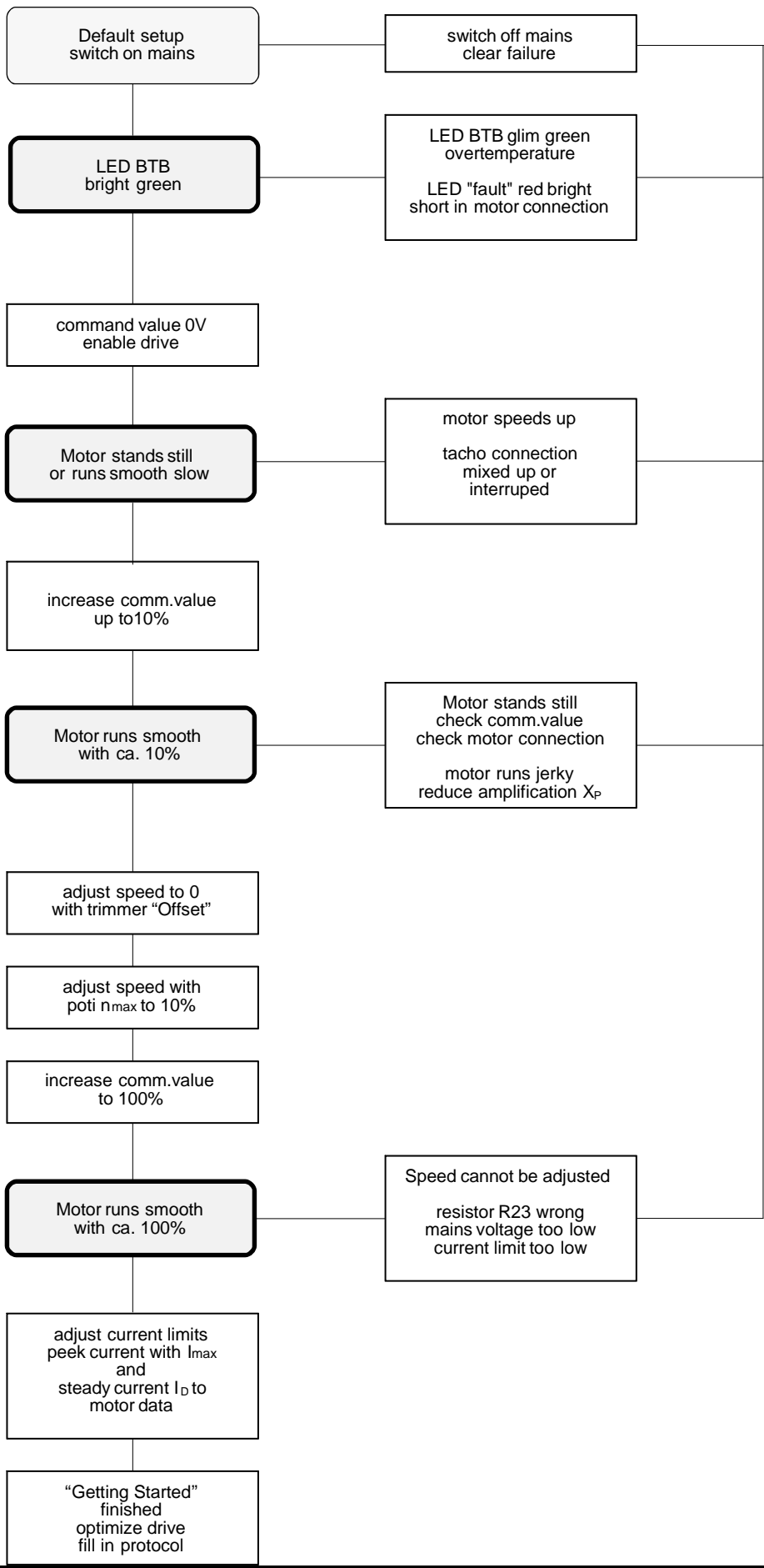

## 7 Fault finding

Function Errors	
Fault	Cause
LED glims green	Overtemperature heat sink
LED bright red	Short in motor line output stage error, overvoltage overvoltage during brakeing
Motor stands still, no torque	Enabled missed Current limit $I_{max}$ anti- clockwise stop motor line interrumped
Motor speeds up	Tachometer polarity wrong Tachometer line interrumped
Motor runs jerky	Amplification $X_P$ too high. command value disturbance
Drive switches to error LED bright red	Overvoltage, motorshort or short to $-U_B$ output stage error
Speed can't be adjusted with trimmer $n_{max}$	Tacho coarse adjustment R23 wrong Jumper J1 wrong, comm.value wrong

## Signalplan Signal scheme

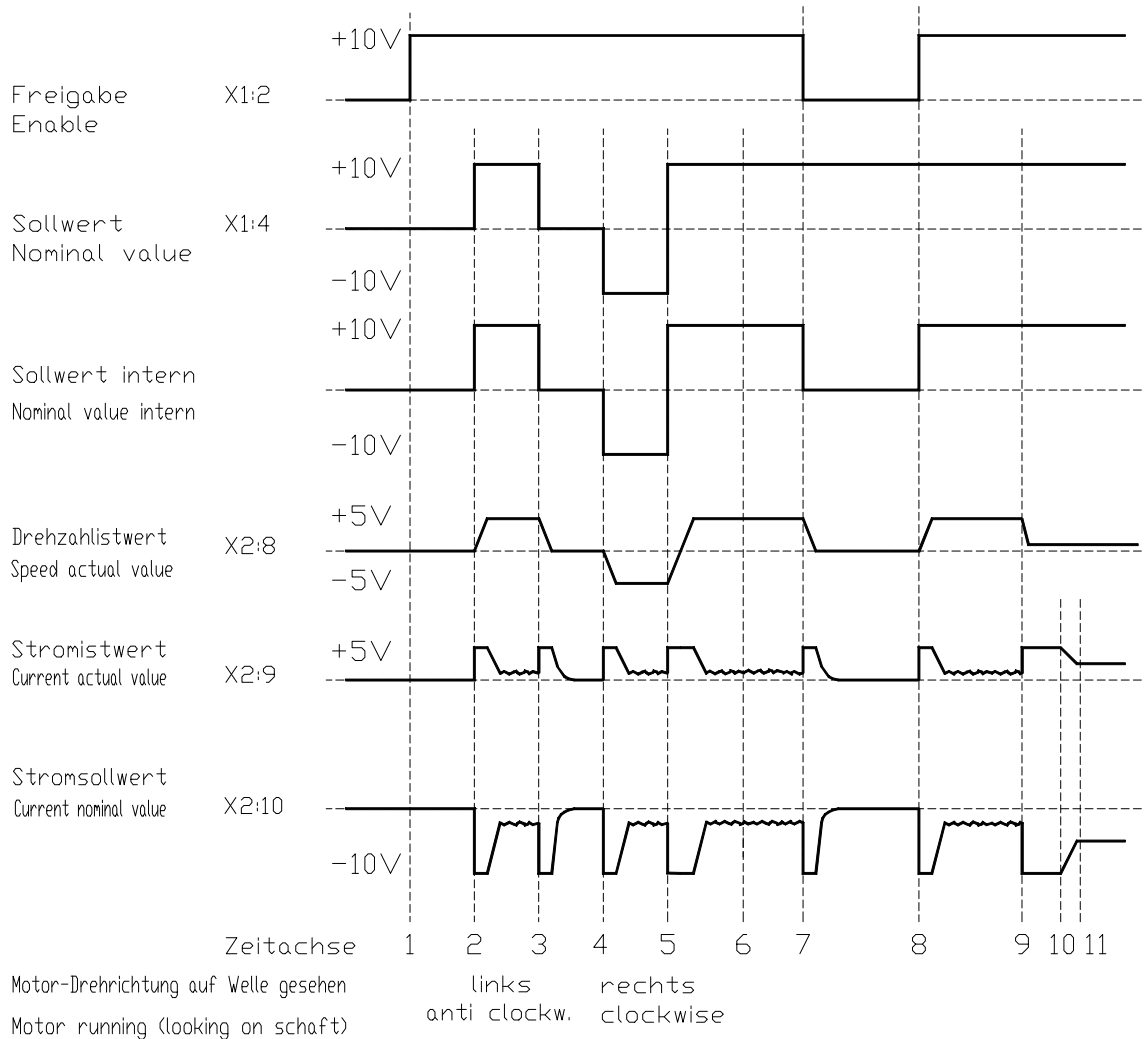

### Time axis

1	Enable on	Motor stands still with torque
2	comm.value positive	Motor accelerates
3	comm.value 0V	Motor decelerates
4	comm.value negative	Motor accelerates
5	comm.value positive	Motor decelerates and accelerates
6	Speed constant	Motor runs with load current
7	Enable off	Motor decelerates, device is locked after 5sec.
8	Enable on	Motor accelerates
9	Overload	Speed brakes down, current increases to maximum peek current
10	Overload >3s	Current is reduced to steady current
11	Steady current limit	

# 8 Commissioning

Commissioning protocol					
Customer			Machine-No.		
Device			Series-No.		
Connection					
Battery voltage [V=]			Auxiliary voltage [V=]		
Fusing [A]			Fusing [A]		
Inputs					
Enable	Contact	SPS/CNC	Voltage [V=]		
command Value	Trimmer	SPS/CNC	Voltage [V=]		
Current command value	External trimmer	SPS/CNC	Voltage [V=]		
Adjustment actual value					
Tachometer	V=/1000UPM		R23[kΩ]		
Armature Voltage	V=/1000UPM		R27[kΩ]		
IxR-Comp.			R8[kΩ]		
Adjustment command value					
Selector switch	S1-cont.1 ON = P		S1-cont.1 OFF = PI		
Selector switch	S1-cont.2 ON = internal		S1-cont.2 OFF = external current limit		
Adjustment speed controller					
P-Component	R9[kΩ]		I-Component	C4[nF]	
Potensiometer positions					
Peek current	I <sub>max</sub> P5	Position			
Steady current	I <sub>D</sub> P4	Position			
Amplification	X <sub>P</sub> P3	Position			
Speed	n <sub>max</sub> P2	Position			
Zero point	Offset P1	Position			
Measuring values					
Motor voltage	max. [V=]				
Tacho voltage	max. [V=]				
Motor current	peek [A=]		steady [A=]		
Motor data					
Producer			Type		
Series-No.		Motor voltage		Motor current	

**UNITEK** products have a warranty against defects in material and workmanship for a period of one year from the date of shipment. All values from the pre- and final quality control checks are archived with the devices' serial numbers.

UNITEK does not guarantee the suitability of the device for any specific application.

During the warranty period, UNITEK will, at its option, either repair or replace products that prove to be defective, this includes guaranteed functional attributes.

UNITEK specifically disclaims the implied warranties or merchantability and fitness for a particular purpose. For warranty service or repair, this product must be returned to a service facility designated by UNITEK.

For products returned to UNITEK for warranty service, the Buyer shall prepay shipping charges to UNITEK and UNITEK shall pay shipping charges to return the product to the Buyer.

However, the Buyer shall pay all shipping charges, duties, and taxes for products returned to UNITEK from another country.

The foregoing warranty shall not apply to defects resulting from:

- \* improper or inadequate repairs effected by the Buyer or a third party,
- \* non-observance of the manual which is included in the all consignments,
- \* non-observance of the electrical standards and regulations
- \* improper maintenance
- \* acts of nature

All further claims on transformation, diminution and replacement of any kind of damage, especially damage, which does not affect the UNITEK device, cannot be considered.

Follow-on damage within the machine or system, which may arise due to malfunction or defect in the device cannot be claimed.

This limitation does not affect the product liability laws as applied in the place of manufacture (i. e. Germany).

**UNITEK** reserves the right to change any information included in this MANUAL.

All connection circuitry described is meant for general information purposes and is not mandatory.

The local legal regulations, and those of the Standards Authorities have to be adhered to.

UNITEK does not assume any liability, expressively or inherently, for the information contained in this MANUAL, for the functioning of the device or its suitability for any specific application.

### **All rights are reserved.**

Copying, modifying and translations lie outside UNITEK's liability and thus are not prohibited. UNITEK's products are not authorized for use as critical components in the life support devices or systems without express written approval.

The onus is on the reader to verify that the information here is current.