

MANUAL

Classic P3

1 Quadrant Thyristor Drive

15 to 40 A



Industrie Elektronik
G m b H

Hans-Paul-Kaysser-Strasse 1
D-71397 Leutenbach 3 - Nellmersbach

Tel.: 07195/9283-0
Fax 07195/928329
email info@unitek-online.de
Http:// www.unitek-online.de

Edition
0308-1

Contents	Page
1. Basic Information	
Safety advice	3
Standards and guidelines	3
General information	4
Features	5
Technical data	6, 7
2. Mechanical Installation	
Dimensions P3 15-25A	8
Dimensions P3 40A	9
3. Electrical Installation	
Connection advice	10
Mains connection	11, 12
Motor connection	13
Field connection	14
CE advice	15
Actual value connection	16
4. Adjustments	
Current control loop	17
Displays	18
5. Commissioning	19, 20
6. Guarantee	21
7. Protocol	22, 23
8. Drawings	
Connections	24
Circuit diagram	25

1 Basic - Information

Electronic equipment is not fault proof. This fact should be borne in mind for all possible operating conditions.

ATTENTION

High voltage

360/550V AC, 450/550V DC

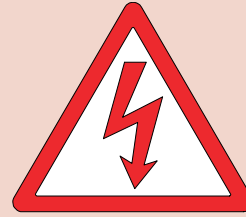

Before installation or commissioning begins, this manual must be thoroughly read and understood by the technical staff involved.

If any uncertainty arises, the manufacturer or dealer should be contacted.

P3 devices are power electric parts used for regulating energy flow.

Protection rating IP00.

Standards and guidelines

The device and its associated components can only be installed and switched on where the local regulations and technical standards have been strictly adhered to:

EU Guidelines	89/392/EWG, 84/528/EWG, 86/663/EWG, 72/23/EWG EN60204, EN50178, EN60439-1, EN60146, EN61800-3
IEC/UL	IEC364, IEC 664, UL508C, UL840
VDE Regulations	VDE100, VDE110, VDE160
TÜV Regulations	

Trade body guidelines VGB4

The user must ensure that in the event of:

- device failure
 - incorrect operation
 - loss of regulation or control
- the axis will be safely de-activated.

It must also be ensured that the machine or equipment are fitted with device independent monitoring and safety features.

Setting adjustments

- should only be carried out by suitably trained personnel
- should only be carried out in accordance with health and safety guidelines

Assembly

- should only be carried out when all voltages have been removed.

QS

Test results are archived with the device serial number by the manufacturer.

CE

The device adheres to the following: Guideline EU 89/336/EWG. EMC standards EN61000-2 and EN61000-4.

Attention

This device description MANUAL P3 only describes the basic control unit and it must be read in conjunction with a control manual (e.g. REG).

The following control units for 1 quadrant control are available:
analogue control REG



General information

In conjunction with a control board (e.g. REG) the Classic P3 range of thyristor drives act as current controllers (moment of inertia controllers).

A 26-pin connector, common to all boards, is used to connect the power section and the control electronics. Using this interface it is possible for any external control arrangement including third party equipment to drive the power section.

P3 drives are used to control the speed, the voltage or the moment of inertia of dc motors.

Build

- switch cabinet mounting according to the VDE, DIN and EU regulations
- standard control electronics REG
- intrinsically safe power section with current control loop
- optional units

Galvanic isolation between

- the power section and the housing
- the power section and the control electronics

The distance of air gaps and leakage paths adhere to the VDE standards (>8mm).

Components

- fully insulated thyristor modules, comfortably over-dimensioned
- only components customary in trade and industrially standardised are used
- high-quality bases for the IC with external connections
- LED displays
- DIP switches for the P-I adjustment of the current control loop
- precision potentiometers for fine adjustments
- plug-in jumpers for the system set-up

Characteristics Series Classic P3

- * Thyristor drive for dc motors
- * Power range 6.75kW to 22kW
- * Drive in the first quadrant
- * Energy recovery
- * Intrinsically safe power section
- * Completely controlled three-phase bridge circuit as output stage
- * Fast analogue current control
- * 26-pin interface
- * Features of the control electronics:
see Manual REG or third-party product documentation
- * Optional units

P3 400/450-x

Power connection 360-440V~
 Auxiliary voltage connection 360-440V~, 200-250V~
 Output voltage max. +450V=
 Cooling self cooling

P3 400/450-		15	25	40
Input current	A~	12	20	32
Output current peak	A=	30	50	80
continuous	A=	15	25	40
El. power	kW	6,75	11,25	18
Input fuses (fast acting) Input	AFF	20	30	50
Mains chokes	Typ mH	KD2-16 0.9	KD2,5-25 0.7	KD2,5-50 0.4
Armature chokes	Typ mH	EI135A-16 33	EI135B-24 16	EI150B-35 8
Dimensions h x w x d	mm	200x160x110	200x160x127	240x160x127

P3 500/550-x

Power connection 500-550V~
 Auxiliary connection 360-440V~, 200-250V~
 Output voltage max. + 550V=
 Cooling self cooling

P3 500/550-		15	25	40
Input current	A~	12	20	32
Output current peak	A=	30	50	80
continuous	A=	15	25	40
El. power	kW	8,25	13,5	22
Input fuses (fast acting) Input	AFF	20	30	50
Mains chokes	Typ mH	KD2-16 1,2	KD2,5-25 0,7	KD2,5-50 0,5
Armature chokes	Typ mH	EI135A-16 33	EI135B-24 16	EI150B-35 8
Dimensions h x w x d	mm	200x160x112	200x160x127	240x160x127

1 Basic - Information

Specification

Mains frequency	50 or 60Hz $\pm 5\%$
Protection rating	IP 00
Format	VDE 0100 group C, VDE 0160
Humidity rating	class F acc. to DIN 40040
Site of installation	< 1000m above sea level
Operating temperature range	0 ... 45°C
Extended operating temp. range	up to 60°C reduced by 2%/°C
Storage temperature range	-30°C to + 80°C

Amplification

- input signal	0 to $\pm 10V=$
- output	0 to $\pm 200\%$ type current
Enable	+10V
Current control loop circuit	
- control precision	$\pm 2\%$
- control range	1:50
Speed control loop circuit with REG	
- control precision (without actual value error)	$\pm 0.1\%$
- control range	1:300

Interface control electronics X3

Function		Connector no.
+ 24V	$\pm 10\%$	X3: 1 and 2
+ 15V	$\pm 2\%$	X3: 3 and 4
- 24V	$\pm 10\%$	X3: 5 and 6
- 15V	$\pm 2\%$	X3: 7 and 8
Device GND		X3: 9, 10, 11, 12, 13, 14
command value (GND)	0	X3: 15
I command value (signal)	+10V=	X3: 16
Current controller enable	+10V=	X3: 17
Drive disable1	+10V=	X3: 18
Drive disable 2	+10V=	X3: 19
N (speed) actual	+10V=	X3: 20
I (current) actual	+10V=	X3: 21
Over-current power section	n/a	X3: 22
Trigger angle1	+10V=	X3: 23
Trigger angle 2	+10V=	X3: 24
Drive ready BTB	+10V=	X3: 25
not assigned	n/a	X3: 26

Classic P3 x/x - 15-40A

Dimensions P3 15-25A

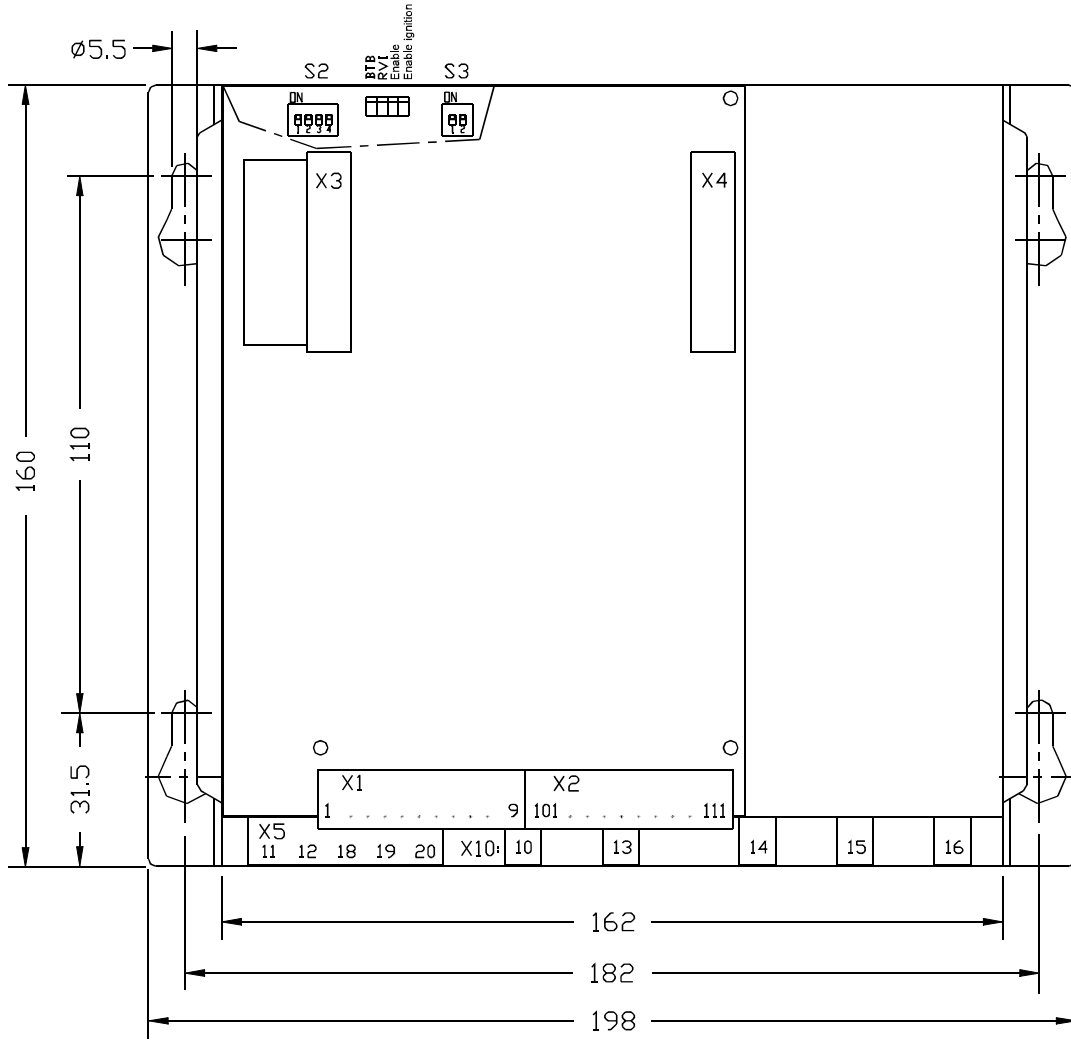

15A

25A

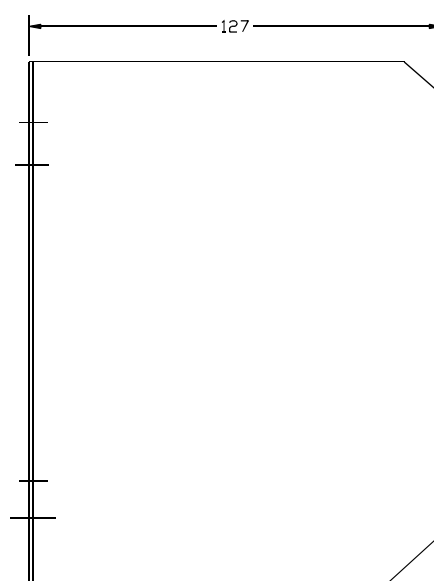
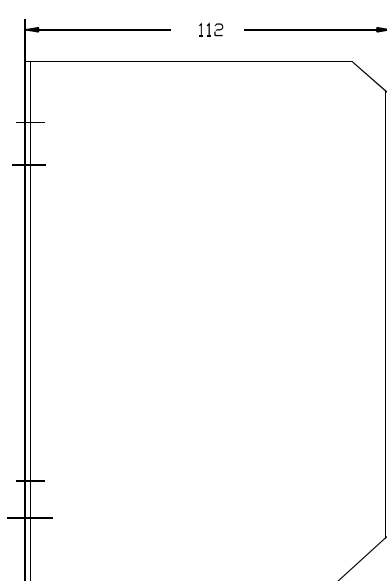

2 Mechanical Installation

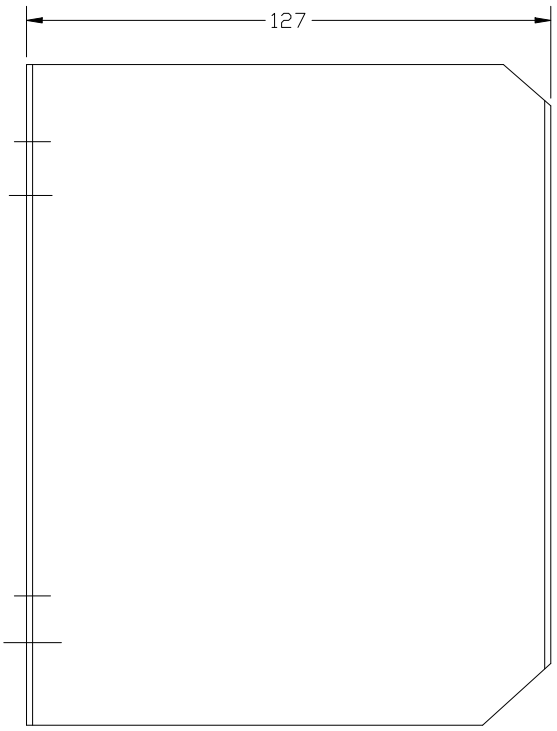
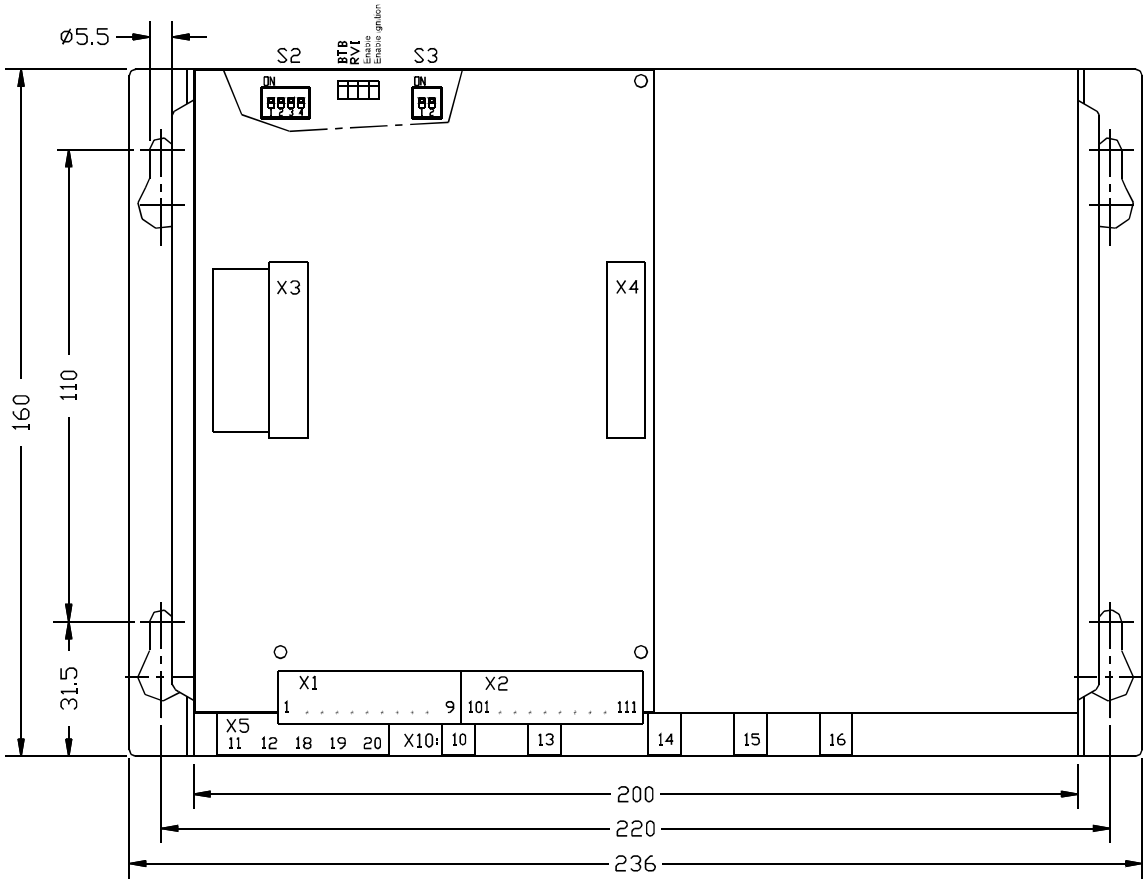

Dimensions P3 40A

Attention:

The order of the connections to the connector numbers or screw terminals is obligatory. All further advice is non-obligatory.

The input and output conductors may be altered or supplemented in accordance with the electrical standards.

Note:

- Connection and operating instructions
- Local regulations
- EU guideline 89/392/EWG, 84/528/EWG, 86/663/EWG
- VDE and TÜV regulations and Trade body guidelines
- CE advice, EMC



Connection Conductor minimal cross-section				
Type current	A	15	25	40
ac power supply	mm ²	1.5	2.5	4
Motor line	mm ²	1.5	2.5	4
Auxiliary voltage	mm ²	0.5	0.5	0.5

3 Electrical Installation

Connection advice

This connection advice is a general information and non-obligatory.

Note:

- Connection and operating instructions
- Local regulations
- EU guideline 89/392/EWG

- VDE and TÜV regulations and Trade body guidelines



Switch on the auxiliary voltage and the supply voltage simultaneously.
Switch off the supply voltage after the auxiliary voltage

Input filter

see CE advice, page 15

Short conductor length to be used between the input filter and the device

Operation with 60Hz: switch S3 contact 1 in position ON

Auxiliary voltage connection

Connection	terminal X5:11, X5:12
Power supply	230V~ or 400V~ (Pls. observe the type plate)
Input current	0.1A
Phase position	regardless
Internal fuses	2.5Af

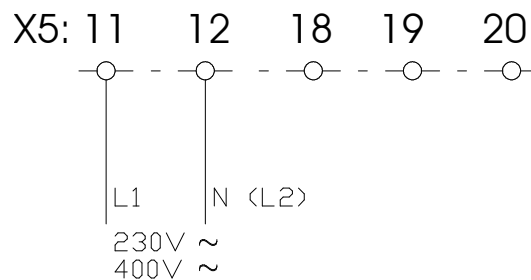

Direct power connection

Connection

Phase	L1	terminal X10:16
Phase	L2 (N)	terminal X10:15
Phase	L3	terminal X10:14

Input fuses

Super fast acting fuses

Power choke

Inductance >200mH

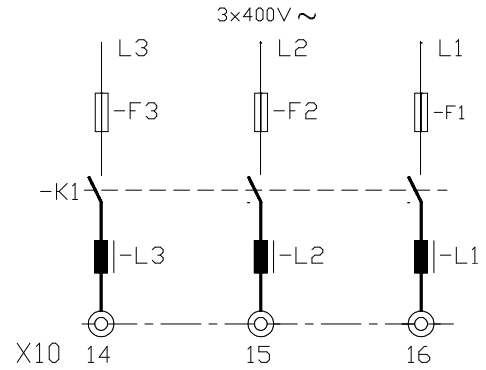

Power connection with a transformer

Transformer performance

1.1 x continuous motor power

Secondary voltage

0.9 x motor power

Transformer fuses

Slow acting

Input fuses

Super fast acting fuses

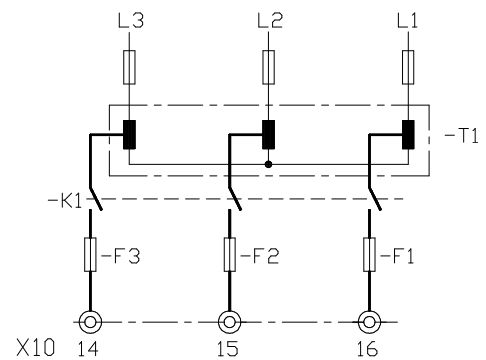

Attention:

If the secondary voltages produced by the transformer are inferior to 60% of the rated device voltage, the voltage watchdog has to be adapted. These modifications may only be effected in the factory and thus, the transformer secondary voltage has to be indicated on order.

Internal watchdog for fuse failures

3 Electrical Installation

Motor connection

Connection

Motor- bolt X10:10
Motor+ bolt X10:13

Armature choke

Inductance: $-L \text{ 4[mH]} = U/I \times 0.8$

Armature chokes are only necessary for special applications, e.g. low-noise motor operation (stagecraft).

Switching in the armature circuit

- dc circuit current-free
- disable inactive

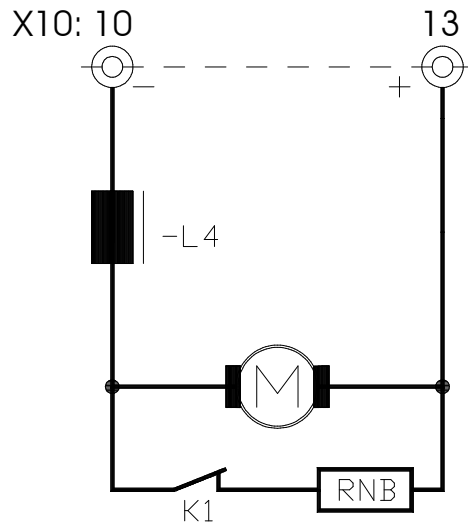

Warning:
Faulty switching will create arcing across the switch contacts.



Power supply failure - brake resistor

Break contact of the mains contactor K1 in parallel to the motor armature without separation from the device

Attention:

Power lines have to be shielded and routed separately from control lines!



For electro-magnetic interferences please refer to the CE advice (page 15).

Field connection

Connection

Input
 Field negative
 Field positive

Plug-in terminal connectors

X5:11, X5:18
 X5:20
 X5:19

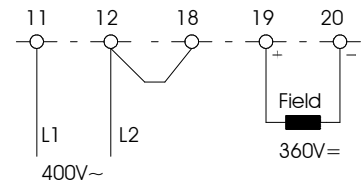
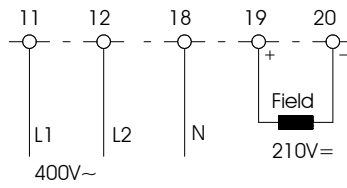
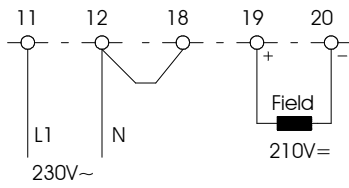

Field voltage

Power supply

230V~
 400V~
 400V~ with N

Field current

Fuses

Watchdog

Field supply

210V=
 360V=
 210V=

max. 1.5A

2.5Af

omitted

3 Elektrical Installation

CE Advice

The devices adhere to the EU guidelines 89/336/EWG and the technical standards EN 61000-2 and 61000-4 provided that the following conditions are observed:

- The device, the power choke, and the filter capacitors are mounted on a 500x500x2 mm mounting plate.
- The mounting plate must be connected to ground using a 10mm² wire.
- The motor housing must be connected to ground using a 10mm² wire.
- The device ground X1:8 must be connected to the mounting plate using a 2.5mm² wire.
- Device PE screw must be connected to the mounting plate using a 4mm² wire, l = 50mm.

Connection:

Power choke type: see technical details
Filter capacitors: 3 x 0.5µF/600V~ 3 x 1µF (x) + 1 x 0.5µF (y)
Conductor length between the device and the power choke <250mm

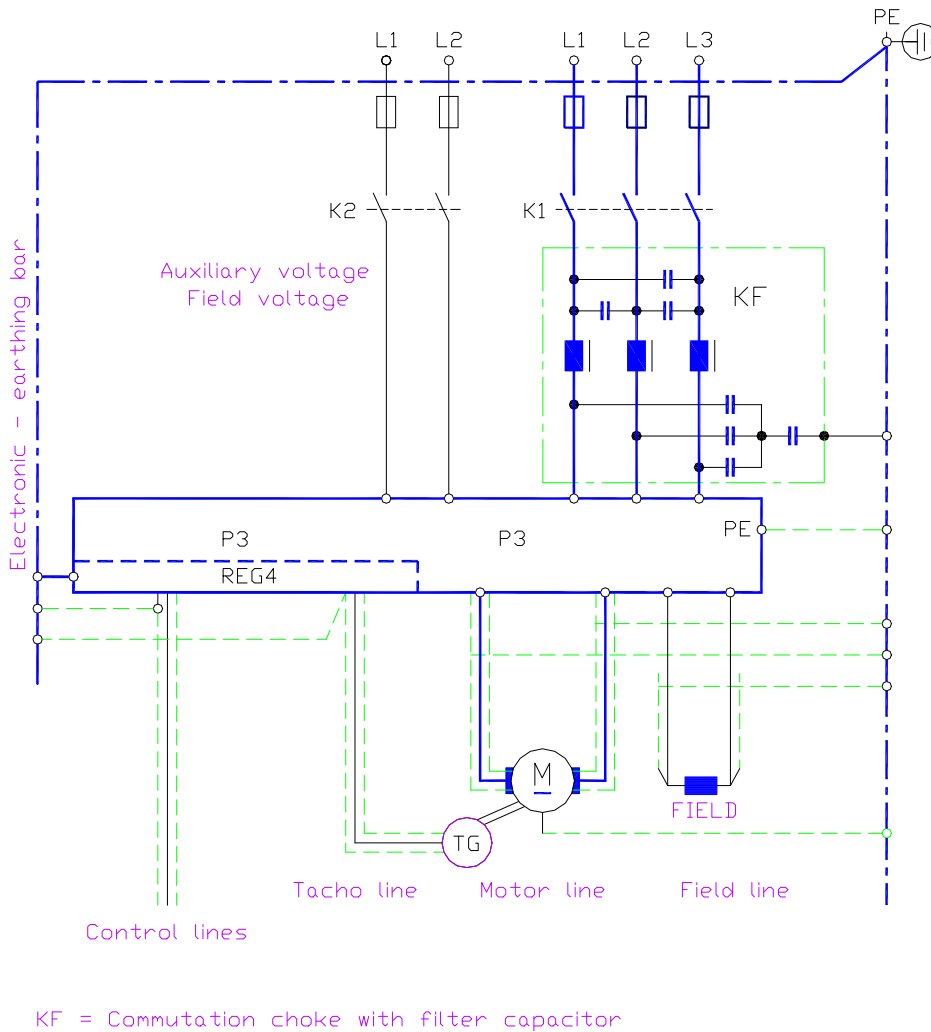

Actual value connection

Tacho

Suitable actual value encoders:

- DC tacho generator
- Brushless tacho generator with evaluation electronics
- Incremental encoders with evaluation electronics
- AC or three-phase tacho with rectification

Connection

Control electronics (see Manual REG)

In case of a positive command value

Tacho positive	X 1:8b
Tacho negative	X 1:9
Shield	X 1:8

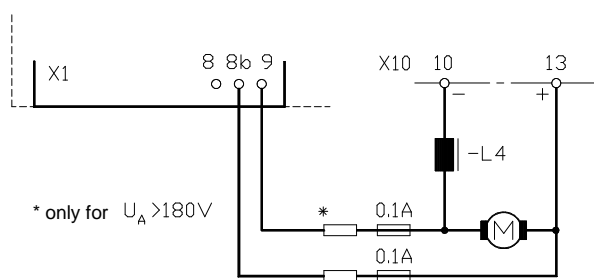
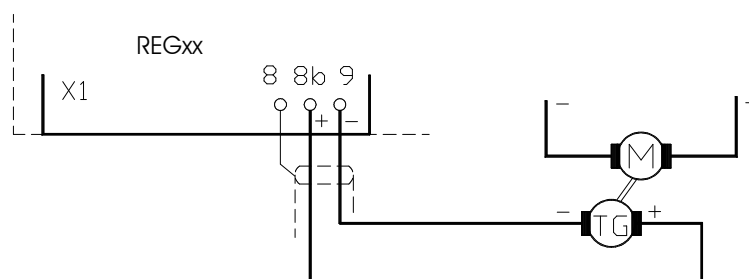

Armature voltage

Ground referenced actual value

Fuses	2x 0.1A/500V	directly in the armature circuit
For armature voltage	>180V=	additional resistors are required
Use unit UNITEK EXZU-UA1		
(including 2 fuses and 2 resistors in an insulated housing)		

4 Adjustment

Adjustments – Current controller

Current controller - PI loop circuit

Adjustments with the DIP switch S2

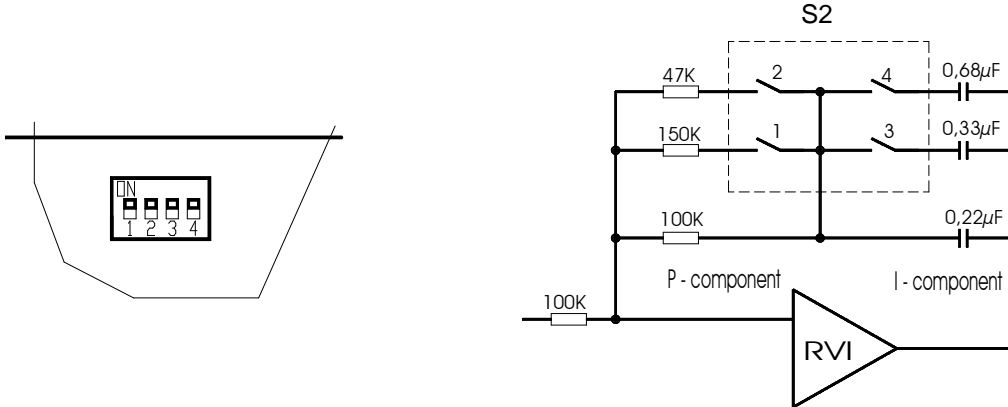

Optimization of the current controller

- Connect an oscilloscope across the current actual value X3:21
- Current command value step-change 1V X3:16
- Increase the current command value by 1V steps to 10V
- Alter the P-amplification by means of the DIP switches S2:1 and S2:2
- Optimal adjustment see fig. 1
- Not permissible adjustment see fig. 2
- Alter the integral part by means of the DIP switches S2:3 and S2:4

Oscilloscope - Current adjustment

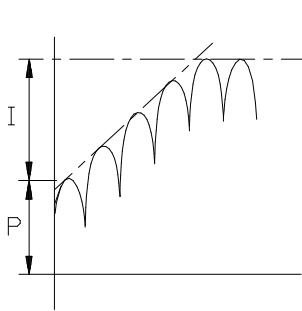

Fig. 1

Optimal adjustment

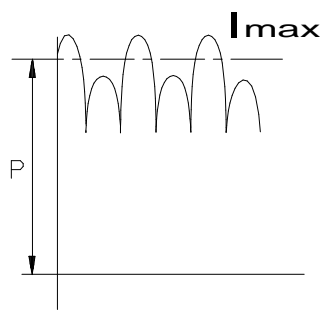

Fig. 2

Amplification too high

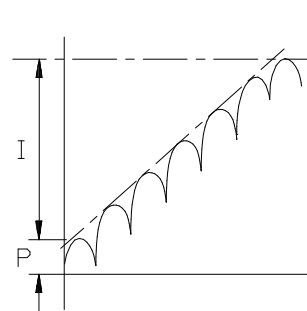

Fig. 3

P-amplification too low

Displays

Some important functions are indicated by LEDs:

Display	LED
Drive ready	BTB
Current controller enable	enable
Triggering enabled	enable triggering
Current command value direction	RVI

The green LEDs indicate the active states!

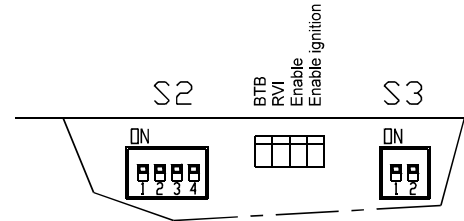

BTB signal - Drive ready

BTB signal	X3:25	>+10V
Error	X3:25	<+2V

Error

Auxiliary voltage supply +24V, +15V, -15V

Power supply:

- Fuse failure
- Under-voltage

In case of errors or failure the power section is internally disabled without delay.

Measurements

Measurement advice

Measuring instruments: multimeters for current and voltage
shunt or clamp-on ammeter

Measuring faults: mean value > actual value
acc. to the form factor
approx. 1 to 5%

Measured values

with a positive command value

Voltage: X10:10 negative, X10:13 positive
max. 1.15 x power supply

Current: ammeter in the motor circuit

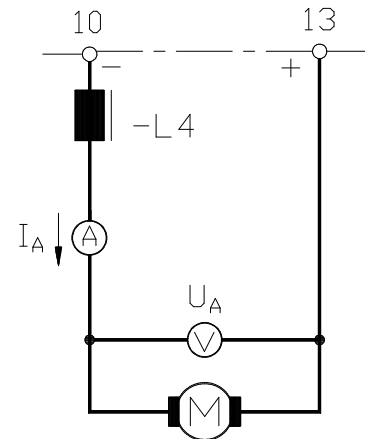

Measured values across REG4

Speed	X2:109	±5V	for ±100% speed
Current	X2:111	±5V	for ±200% current
GND	X2:104		

5 Commissioning

Commissioning

1. Connection advice

Connect the drive in accordance with the P3 manual and the control electronics manual (e.g. REG).

Please observe in particular:

- Check the power supply voltage with that specified on the type plate.
- Insert the correct fuses according to the technical data (rf. to page 6)
- Check the field voltage connection and the motor and tacho connections!
- For 60Hz applications set the switch S3, contact 1 to ON

2. Commissioning

Basic connections:

Mains supply, field, tacho, or armature feedback, drive enable, command value.
For armature voltage control the tacho watchdog must be switched off.

2.1 Drive enable switch open or drive enable voltage 0V

Command value		0V
Switch S9		adjust to tacho voltage
for armature voltage control		adjust to 0
Switch S4		position 2
Switch S5		position 6
Potentiometer I _{max1}		left full scale
Potentiometer I _{max2}		adjust to approx. 10% of full scale
Potentiometer	XP	adjust to 50%
Potentiometer	ID	= 10
Potentiometer	I _{xR}	= left full scale
Potentiometer	n _{max}	= left full scale
Potentiometer	INT	= left full scale

2.2 Apply the voltage

The LEDs L3 (BTB) and L7 (stationary) **must** light.
All other LEDs are off.

2.3 Close the switch 'drive enable' or apply a drive enable voltage of 10V

The LEDs L1 and L2 must also light

The drive must be at a standstill or turn slowly (offset).

If the drive accelerates in the correct direction, the polarity of the tacho voltage and the armature voltage feedback must be changed.

If the drive accelerates in the wrong direction, the polarity of the armature or the field must be changed.

2.4 Increase the command value voltage to approx. 10%

The drive must accelerate to approx. 10% of the speed.

If the rotation direction is wrong, change the polarity of the tacho and the field or the polarity of the tacho and the armature.

2.5 Current controller amplification

(Switch S2 on the power section)

The current amplification is adjusted to a low armature circuit inductance (all switches "On")

High inductance values can lead to motor oscillation which cannot be influenced by means of the speed controller.

In this case, first set switch S2-2 to "Off".

If the drive still does not run smoothly, set the switch S2-1 to "Off".

The current response can be measured by means of an oscilloscope across the test point X4:20 (see page 17).

2.6 Speed controller amplification

Adjust on the REG board.

Adjust the P-term to the lowest possible setting from 1 to 5 (switch S4).

Adjust the I-term to match the axis momentum (switch S5):

large axis momentum - high adjusted value

small axis momentum - low adjusted value

With the command value set to 10% speed, increase the amplification by turning the potentiometer Xp clockwise. When the drive begins to oscillate, reduce the amplification by turning the potentiometer anti-clockwise by approximately 10%.

For the fine adjustment of the amplification the control response should be measured by means of an oscilloscope across the test point X4:15.

2.7 Further adjustments

such as speed, peak current, continuous current, etc.

(rf. to the manual REG and P3)

2.8 Switching Off

If the switch 'drive enable' is opened, or the drive enable voltage is switched to 0V, LED L1 and L2 will extinguish and the drive will be disabled.

DIP switch DS1:K4 (REG4) in position OFF!

After approx. 2s the thyristor triggering circuit is disabled.

2.9 Commissioning adjustments

The adjustments should be documented in the protocol and the adjustment potentiometers should be sealed with a suitable lacquer.

Guarantee

UNITEK guarantees that the device is free from material and production defects. Test results are recorded and archived with the serial number.

The guarantee time begins from the time the device is shipped, and lasts one year. Unitek undertakes no guarantee for devices which have been modified for special applications.

During the warranty period, UNITEK will, at its option, either repair or replace products that prove to be defective, this includes guaranteed functional attributes. UNITEK specifically disclaims the implied warranties or merchantability and fitness for a particular purpose. For warranty service or repair, this product must be returned to a service facility designated by UNITEK.

For products returned to UNITEK for warranty service, the Buyer shall prepay shipping charges to UNITEK and UNITEK shall pay shipping charges to return the product to the Buyer.

However, the Buyer shall pay all shipping charges, duties, and taxes for products returned to UNITEK from another country.

The foregoing warranty shall not apply to defects resulting from:

- * improper or inadequate repairs effected by the Buyer or a third party,
- * non-observance of the manual which is included in all consignments,
- * non-observance of the electrical standards and regulations
- * improper maintenance
- * acts of nature

All further claims on transformation, diminution, and replacement of any kind of damage, especially damage, which does not affect the UNITEK device, cannot be considered. Follow-on damage within the machine or system, which may arise due to malfunction or defect in the device cannot be claimed.

This limitation does not affect the product liability laws as applied in the place of manufacture (i. e. Germany).

UNITEK reserves the right to change any information included in this MANUAL.

All connection circuitry described is meant for general information purposes and is not mandatory.

The local legal regulations, and those of the Standards Authorities have to be adhered to. UNITEK does not assume any liability, expressively or inherently, for the information contained in this MANUAL, for the functioning of the device or its suitability for any specific application.

All rights are reserved.

Copying, modifying and translations lie outside UNITEK's liability and thus are not prohibited. UNITEK's products are not authorised for use as critical components in the life support devices or systems without express written approval.

The onus is on the reader to verify that the information here is current.

Protocol

Customer Machine No.

Device Serial No

Control voltage [V~]

Power supply voltage [V~]

Field voltage [V=]

Inputs

Enable	contact ?	voltage [V=]
Command value	type	voltage [V=]
Command value, additional	type	voltage [V=]
Current command value I_{max2}	external	voltage [V=]

Speed controller settings

Switches

Tacho adjustment	S9	Position
P-term	S4	Position
I-term	S5	Position
D-term	S8	Position

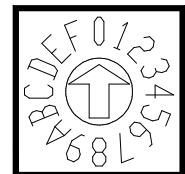

Potentiometers

Speed	n_{max}	P4	Position
Peak current	I_{max1}	P5	Position
Peak current	I_{max2}	P6	Position
Continuous current	I_D	P7	Position
Integrator	INT	P1	Position
Amplification	XP	P3	Position
I_xR compensation		P2	Position

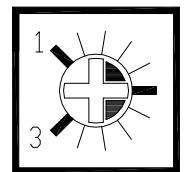
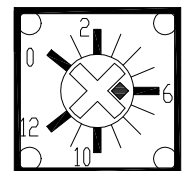

DIP switches

ON	no.
OFF	no.

Current controller settings

Switches

Switches S2	open	(off)
	closed	(on)
Switch S3, contact 1	60Hz	on	
	50Hz	off	

Measured data

Armature voltage	max.	[V=]
Armature current	peak	[A=]
Armature current	continuous	[A=]
DC tacho voltage	max.	[V=]
Tacho voltage	max.	[V=]
Acceleration	X4:16	[V/ms]
Integrator	X4:14	[V/ms]

Motor data

Type plate data

Manufacturer	
Type	Serial number
Motor voltage [V=]	Motor current [A=]
Brake [V]	Fan [V]

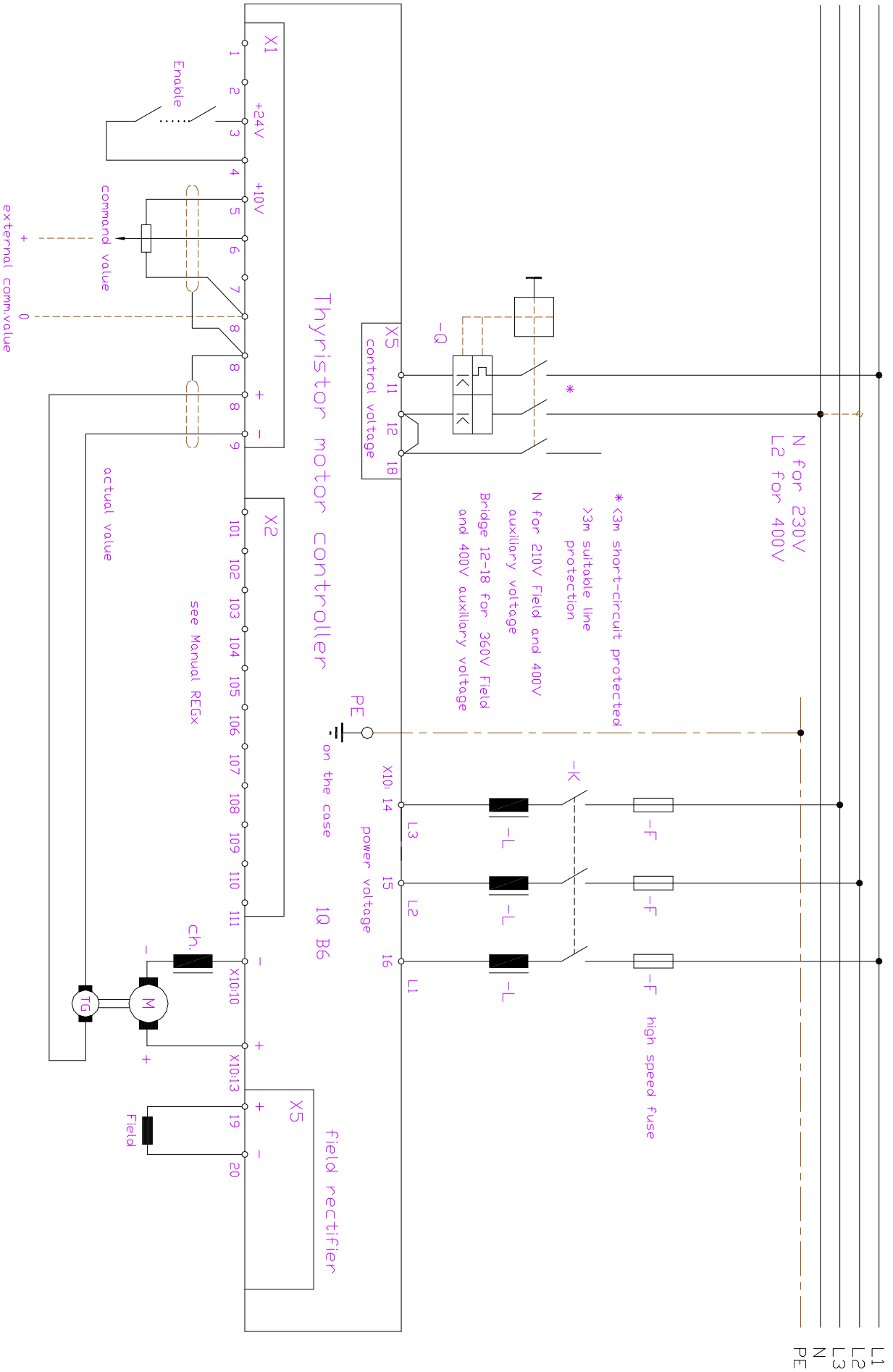

Connection Diagram

