

MANUAL

Digital 3-phase Servo-Drive

DS 2420, DS 4820

for EC/AC servo motors

- Battery connection -

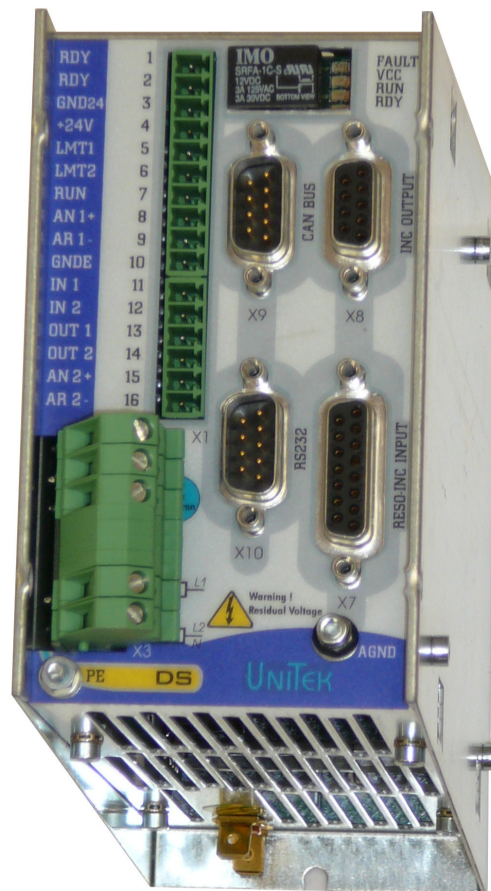

Unitek

Industrie Elektronik
G m b H

Hans-Paul-Kaysser-Strasse 1
D-71397 Leutenbach 3 - Nellmersbach

Tel.: 07195/9283-0
Fax 07195/928329
email info@unitek-online.de
Http// www.unitek-online.de

Version 0110-V6

DS 2420, DS 4820

Content

Part 1 Hardware manual

Page

1.	Basic information	
1.1	Safety advice, standards and guidelines	3,4
1.2	General Information	5
1.3	Applications	6
1.4	Build, Features	7
1.5	Technical data	8,9
2.	Mechanical installation	
	Important advice	11
2.1	Dimensions DS 2420, DS 4820	12
2.2	Dimensions accessories	13
2.3	Mounting	14
3.	Electrical installation	
	Important advice	15
3.1	Circuit diagram	16,17
3.2	Connections EC/AC	18
3.3	Connectors DC	19
3.4	Connectors	20
3.5	Battery connection	21
3.6	Motor connection EC/AC	22
3.7	Motor connection DC	23
3.8	Control signals	24,25
3.9	Interfaces	26,27
3.10	Resolver	28
3.11	Encoder	29
3.12	Sin/Cos connection for DSxx-SC	30
3.13	Rotor position	31
3.14	X8 encoder - output-input	32,33
3.15	LED displays	34
3.16	Error message	35
3.17	Warning message	36
3.16	Options	37
	Guarantee	38

Part 2 Software manual

Part 3 Commissioning instruction

Part 4 Software reference

Part 5 CAN-BUS reference

Dokumentation erstellt mit
und

COREL VENTURA 8™
Adobe Acrobat 5.0™

2 Basic Information

Electronic equipment is not fault proof. This fact should be borne in mind for all possible operating conditions.

ATTENTION - DC voltage

DC 60V=

Discharge time of the bus circuit >4 min!

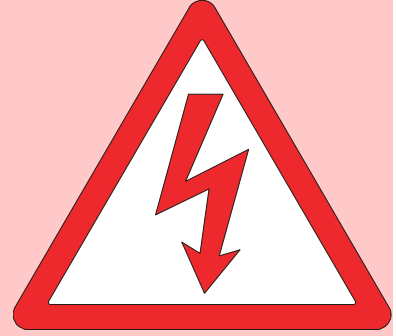

Before installation or commissioning begins, this manual must be thoroughly read and understood by the technical staff involved.

If any uncertainty arises, the manufacturer or dealer should be contacted.

Any incorrect installation or assembly may damage or destroy the units.

DS xx devices are power electric parts used for regulating energy flows. They are designed for the control of EC synchronous motors (brushless dc motors, BLDC) for industrial applications and they are part of an electric drive (PDS).

Protection rating IP20 for switch cabinet mounting.

Connection only to an earthed ac or three-phase power supply.

Standards and guidelines

The device and its associated components can only be installed and switched on where the local regulations and technical standards have been strictly adhered to:

EU Guidelines	89/392/EWG, 84/528/EWG, 86/663/EWG, 72/23/EWG EN60204, EN50178, EN60439-1, EN60146, EN61800-3
IEC/UL	IEC364, IEC 664, UL508C, UL840
VDE Regulations	VDE100, VDE110, VDE160
TÜV Regulations	
Trade body guidelines	VGB4

The control and power connections may be voltage-carrying without the axis operating!

The discharge time of the bus circuit is superior to 4 min!

Measure the voltage before any disassembly!

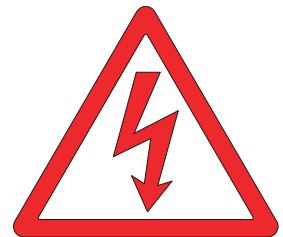

The user must ensure that in the event of:

- device failure
 - incorrect operation
 - loss of regulation or control
- the axis will be safely de-activated.

It must also be ensured that the machine or equipment are fitted with device independent monitoring and safety features. Man as well as property must not be exposed to danger at any time.



Assembly

- should only be carried out when all voltages have been removed.
- should only be carried out by suitably trained personnel.

Installation

- should only be carried out when all voltages have been removed.
- should only be carried out by suitably trained personnel
- should only be carried out in accordance with health and safety guidelines

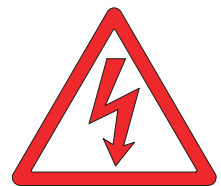

Setting adjustments/programming

- should only be carried out by suitably trained personnel with knowledge in electronic drives and their software
- should only be carried out in accordance with the programming advice
- should only be carried out in accordance with health and safety guidelines

CE

After having been mounted in machines and installations the operation of the device must not be started until the machine or the installation has been approved of the regulations of the EC machine guideline 89/392/EEG and the EMC guideline 89/336/EEG.

Under the installation and test conditions of chapter 'EMC advice' the device adheres to the following: guideline EU 89/336/EEG, EMC standards EN61000-2 and EN61000-4.

A manufacturer's declaration can be asked for.

QS

Test results are archived with the device serial number by the manufacturer for a period of 5 years. Test protocols can be asked for.

Safety symbols

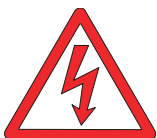

Caution - Danger to life
High voltage



Attention
Warning
Important

2 Basic Information

General information

The digital 3-phase current servo amplifier **DS xx** in combination with the brushless dc motor (synchro servo motor, CE motor) provide a drive solution free of maintenance and with a wide dynamic control range. The drive displays the well-known good control characteristics of dc drives without the disadvantages of the carbon brushes' wear and the commutation limits. The rotor moment of inertia is notably lower and the threshold power is greater than with equally constructed dc motors. This results in up to 5 times higher acceleration values. Compared to asynchronous motors with frequency converters the stability, the control range and the efficiency of the drive are considerably improved. The generated heat in the motor only occurs in the stator, therefore, the EC motors always have the protection rating IP 65.

From the electrical view, the brushless dc motor is a synchro motor with a permanent magnet rotor and a three-phase current stator.

The physical characteristics correspond to those of dc motors, i.e., the current is proportional to the torque and the voltage is proportional to the speed. The speed is steadily controlled up to the current limit (max. torque. In case of an overload the speed drops and the current remains constant.

The speed/torque characteristic is rectangular.

Current, speed, and position are precisely measured. The field frequency is not controllable, it is automatically adjusted.

The motor voltages and the motor currents are sinusoidal. A maximum motor efficiency is achieved by means of a compensating current control.

The DS 2420 drives can be used as single-axis position amplifier or torque or speed amplifier.

The position and speed actual value is generated in the encoder unit (resolver or incremental encoder). The encoder pulses are emitted from the amplifier for a superordinate PLC/CNC control. The control circuits of current, speed, and position are PID controllers which are easy to program. They can be programmed by means of a PC or a programming box. The communication with superordinate controls is effected by means of BUS systems (standard CAN-BUS, RS232) or by analogue interfaces.

Note:

The energy is fed back into the battery during brake operation.
No ballast (regen) circuit.

For any operation via a mains supply circuit (without battery) a separate ballast circuit or a voltage watchdog must be installed.

Information:

Digital servo-amplifiers	> UNITEK series DS200, DS400
Analog three-phase servo-amplifiers	> UNITEK series TVD3, TVD6, AS
Analog dc servo-amplifiers	> UNITEK series TV3, TV6, TVQ6
Thyristor current converters 1Q, 4Q, servo	> UNITEK series <i>Classic</i> , 200W to 800kW
DC and ac servo-amplifiers for battery operation analog and digital	> UNITEK series BAMO A2, A3, D3 series BAMOBIL

Applications

Battery-driven machines and installations for all types with a drive power of 1kW especially as 4Q-servo-drive for

- highly dynamic acceleration and braking cycles
- a wide control range
- a high efficiency
- small motor dimensions
- a uniform, accurate and smooth running

For speed or torque control or combined speed/torque control incorporated within or independent of position control loops.

Drives with constant speed as in conveyors, spindle drives, pumps, transversal or longitudinal pitch drives.

Synchronous multiple motor drives.

Synchro-servo-drives are more compact than other electric drives.

Particularly suitable for:

component equipment inserting machines, testing machines, sheet-metal working machines, machine tools, plastic working machines, assembly machines, knitting and sewing machines, textile working machines, grinding machines, wood and stone working machines, metal working machines, food processing machines, robots and handling systems, conveyors, extruders, calenders, and many other machines and installations.

Motor features

- protection rating IP 65
- compact
- suitable for rough surroundings
- suitable for high dynamic overload
- free of maintenance

Note

Brushless drives are used where braking operations are predominant, e.g. when deceleration is mainly required:

- winding machines, lifts, great centrifugal masses, vehicles

The braking energy is fed to the battery.

For any operation via a mains supply circuit (without battery) a separate ballast circuit or a voltage watchdog must be installed.

2 Basic Information

Build

- devices for switch cabinet mounting, steel housing, according to the VDE, DIN and EC regulations, protection rating IP20, VGB4
- standard digital control electronics
- power electronics for 20A (S1 operation)
- battery power input voltage 24V= or 48V=
- independent 24V chopper power supply unit for the auxiliary voltages

Galvanic isolation

- between the housing and all electric parts
- between the auxiliary voltage connection and the power section and the control electronics
- between the power section and the control electronics
- between the control electronics and the logic inputs
- the distance of air gaps and leakage paths adhere to the VDE standards

Components

- FET power semi-conductors, comfortably over-dimensioned
- only components customary in trade and industrially standardised are used
- SMD equipment
- LED displays

Characteristics

- * EMC protected steel housing
- * battery connection 24V= or 48V=
- * independent auxiliary voltage connection 24V=
- * digital interfaces RS232, CAN-BUS (further option)
- * analogue inputs, programmable differential inputs
- * digital inputs/outputs, programmable, optically de-coupled
- * logic for enable and the output stage switch
- * BTB ready for operation, relay contact
- * position, speed and torque control
- * resolver or incremental encoder (sine encoder option)
- * encoder output
- * static and dynamic current limiting
- * uniform, completely digital control unit
- * intrinsically safe and short-circuit proof power section
- * processor-independent hardware switch-off in case of short-circuits, circuits to earth, over-voltage, under-voltage, and over-temperature of the amplifier or the motor

Power supply connection	Battery 24V= ; Battery 48V=
Auxiliary voltage connection	24V= $\pm 10\%$ / 2A, Residual ripple <10%,regenerating fuse

Specification	Dim.	DS2420	DS 4820	DS2420-DC	DS 4820-DC
Supply voltage nominal value	V \sim	24	48	24	48
Max.output voltage, Max.nominal value	V \sim eff	3x14	3x32	22	45
Power input S1 max.	VA	700	1400	700	1400
Power output S1 max.	W	500	1000	500	1000
Continuous current	A _{eff}	20			
Max. Peak current	A _{lo}	40			
Max. Power loss	W	60	65	60	65
Pulse frequency	KHz	8			
Over-voltage switching treshold	V=	38	66	38	66
under-voltage switching treshold	V=	18	32	18	32
Input fuse	A	30			
Weight	kg	1.2			
dimensions h x w x d	mm	140x70x190			
Unit size		1			

Control signals	V	A	Function	Connector	
Analog inputs	± 10	0.005	Differential input	X1	
Digital inputs	ON OFF	10- 30 <6	0.010 0	Optically decoupled	X1
Digital output	+24	0.03	Optically decoupled	X1	
Resolver			Differential input	X7	
Encoder input	>3.6V		Optically decoupled	X7	
Encoder output	>4.7		Optically decoupled	X8	
CAN interface			Optically decoupled	X9	
RS232 interface			9600 baud	X10	

3 Basic Information

Specification	
Protection rating	IP20, VGB4
standards	EN60204,
Operating temperature range	0 to +45°C
Extended operating temperature range	+45°C to +60°C performace reduced by 2%/°C
Storage temperature	-30°C bis +80°C
Humidity rating	Class F humidity <85%, no condensation allowed !
Site of installation	≤ 1000m above sea level 100%, >1000m performace reduced by 2%/100m
Ventilation	Internal fans
Mounting position	Vertical; performace reduced by 20% when mounted horizontally

Programming	Version	Software version	Extension
DS-4xx-x	RESO- 12bit	DRIVE_DS 2.	
DS-4xx-x	RESO- 12/16bit		
DS-4xx-x	Encoder		-IN
DS-4xx-x	Sine encoder		-RS

Free



4 Mechanical Installation

Important instruction

Blank mounting surface, no lacquer (EMC surface-to-surface contact)

Check the device for mechanical damage. Only perfect devices can be mounted.

Disconnect the power supply prior to any assembly.

For installations connected to an electric power supply install the shorting plug and affix the warning signs.

The device must only be mounted by suitably trained personnel.

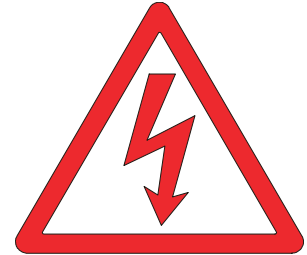

Vertical mounting position.

Please note that there will be a performance reduction when the devices are mounted horizontally (10%).

Ensure that the ventilation is sufficient and that there is enough space for the discharged ventilation air (min. 100mm).

Any bore hole dimensions for the fixation of the device must be taken from the dimension diagrams or from the drilling plan, not from the device.

Drill the mounting bore holes (M4) into the mounting plate. Turn-in the screws to 4mm. Insert the device and fasten the screws.

The filter and the choke have to be mounted near to the device.

The line shields and the mounting plate must have surface-to-surface contact.

Unshielded cable heads must be kept as short as possible.

Use vibration-proof screw connections.

Ensure that the switch cabinet ventilation is sufficient.

If the ambient temperature is too high ($>30^{\circ}\text{C}$) an air conditioning unit has to be installed.

Note: The operation of bedewed devices is not permissible.



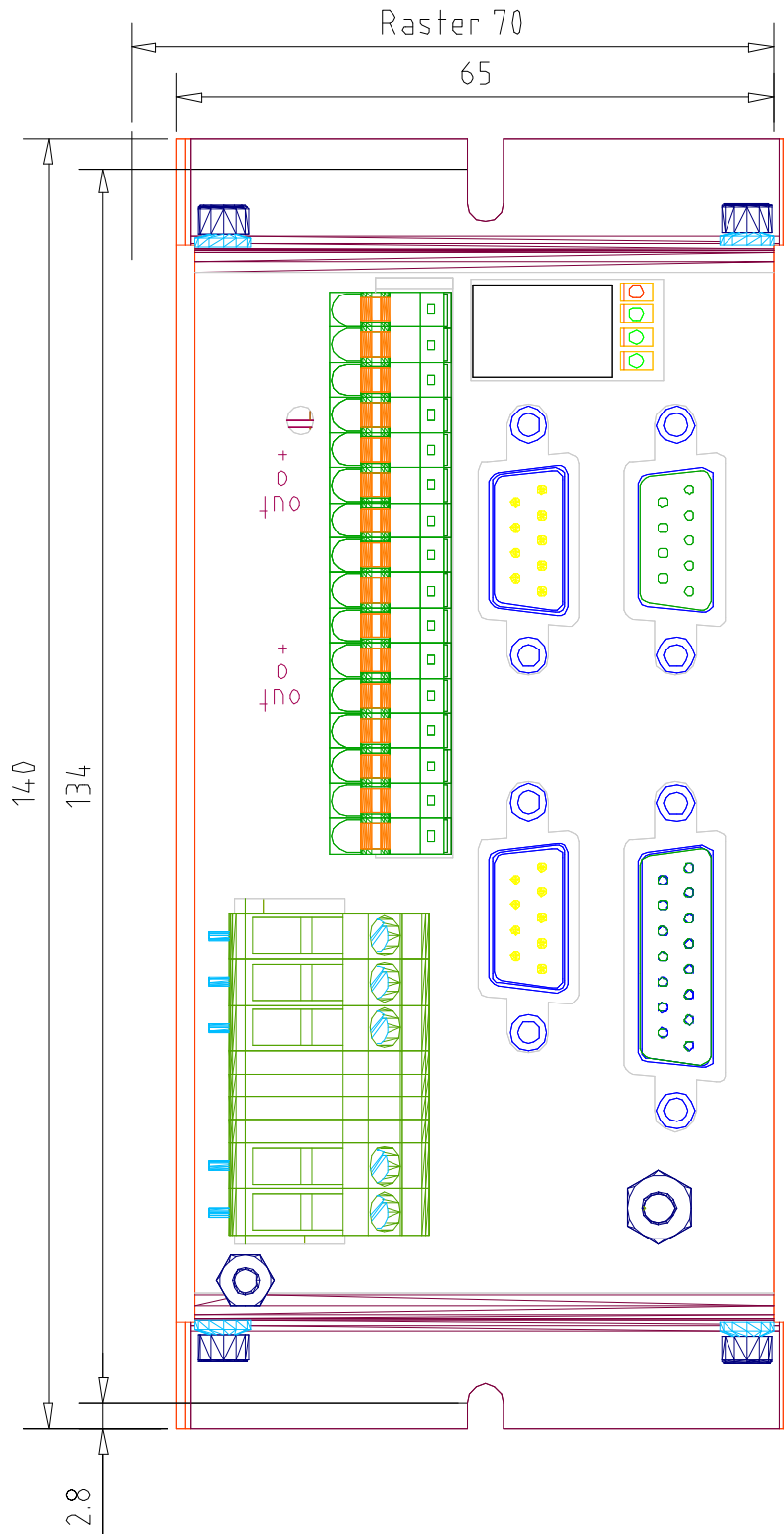

Dimensions

Size 1

DS 2420 to DS 4820

Mounting depth

Fixing screws:

without connector 190 mm
 with connector max. 250mm
 M4 x 10 (DIN 912 recommended)

4 Mechanical Installation

Dimensions - Motor choke

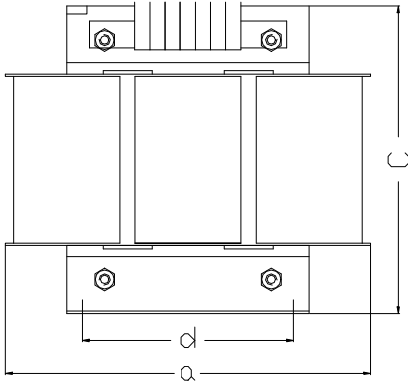

Type	Current	Induct.	Dimensions	w.
	A	mH	H x w x d mm	kg
MDD 1.6b-10	10	1	95x58x108	1.4
MDD 2b-20	20	0.8	128x80x140	2.6

Motor choke only with a cable shield capacity of $>5\text{nF}$.

Cable length: approx. 25m

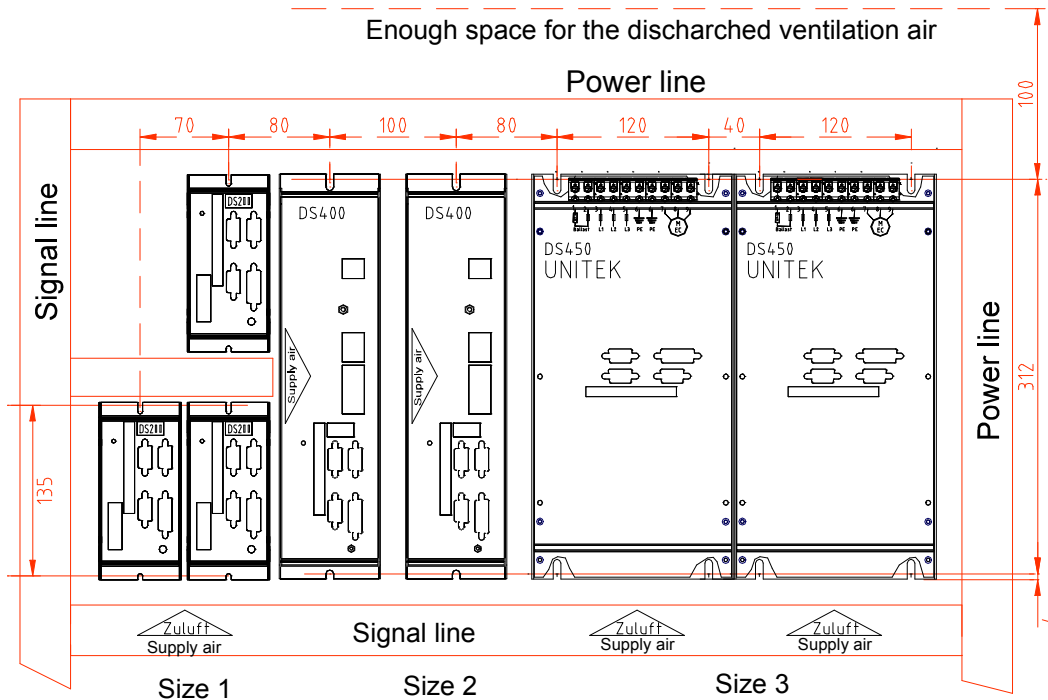

In order to achieve good EMC values, it is recommended to use bright, unpainted mounting plates. The bright surface of the device's rear panel ensure a good surface-to-surface contact.

The signal lines and the power supply lines must be routed in separate trunkings with rectangular crossings (spatial separation of the disturbance coupling).

Mounting instruction

Recommended fixing screw
DIN 912 M4x12 with safety washer

Bore threaded M4 holes at a right angle
distance of 312mm.
Drilling template included.

Turn in the M4x12 screws.
Distance to the rear panel of the switch
cabinet approx. 4mm

Position the upper edge of the device (1)
and push it up against the stop (2). Then
push the lower part of the device against
the switch cabinet's rear panel (3) and lower
it (4).

Fasten the screws.

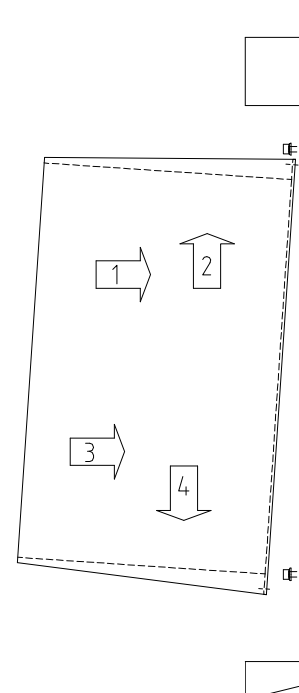

5 Eleectrical Installation

Important note:

The order of the connections to the connector or terminal numbers is obligatory. All further advice is non-obligatory.

The input and output conductors may be altered or supplemented in accordance with the electrical standards and guidelines.

Adhere to:

- connection and operating instructions
- local regulations
- EU guideline 89/392/EWG
- VDE and TÜV regulations and Trade body guidelines

Electrical installation should only be carried out when all voltages have been removed!

Ensure that the device is safely disconnected from the power supply

- place the shorting plug
- affix warning signs

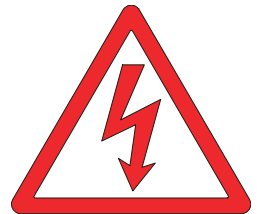

The installation should only be carried out by suitably trained personnel for electrical engineering.

- Compare the connection data with those indicated on the type plate.
- Ensure that the correct fuses have been provided for the power supply and the auxiliary voltage.
- Power supply conductors and control lines must be routed separately from each other.

Connection shields and grounding must be carried out in compliance with the EMC guidelines. Use the correct line cross-sections.

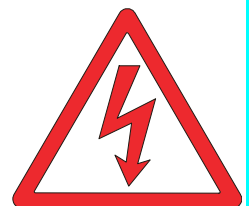

Type plate (example)
Serial no.

UniTek	Industrie Elektronik	
	G m b H	
	CE	
726 3-phase Servo drive		
DS 412-RS		
Power supply	3 1(x)30V~ to	480V~
Rated current	12A eff	IP20
Auxiliary voltage	24V=	
Tel. +49 (0)7195/9283-0	Info@unitek-online.de	
Fax +49(0)7195/928329	www.unitek-online.de	

044444

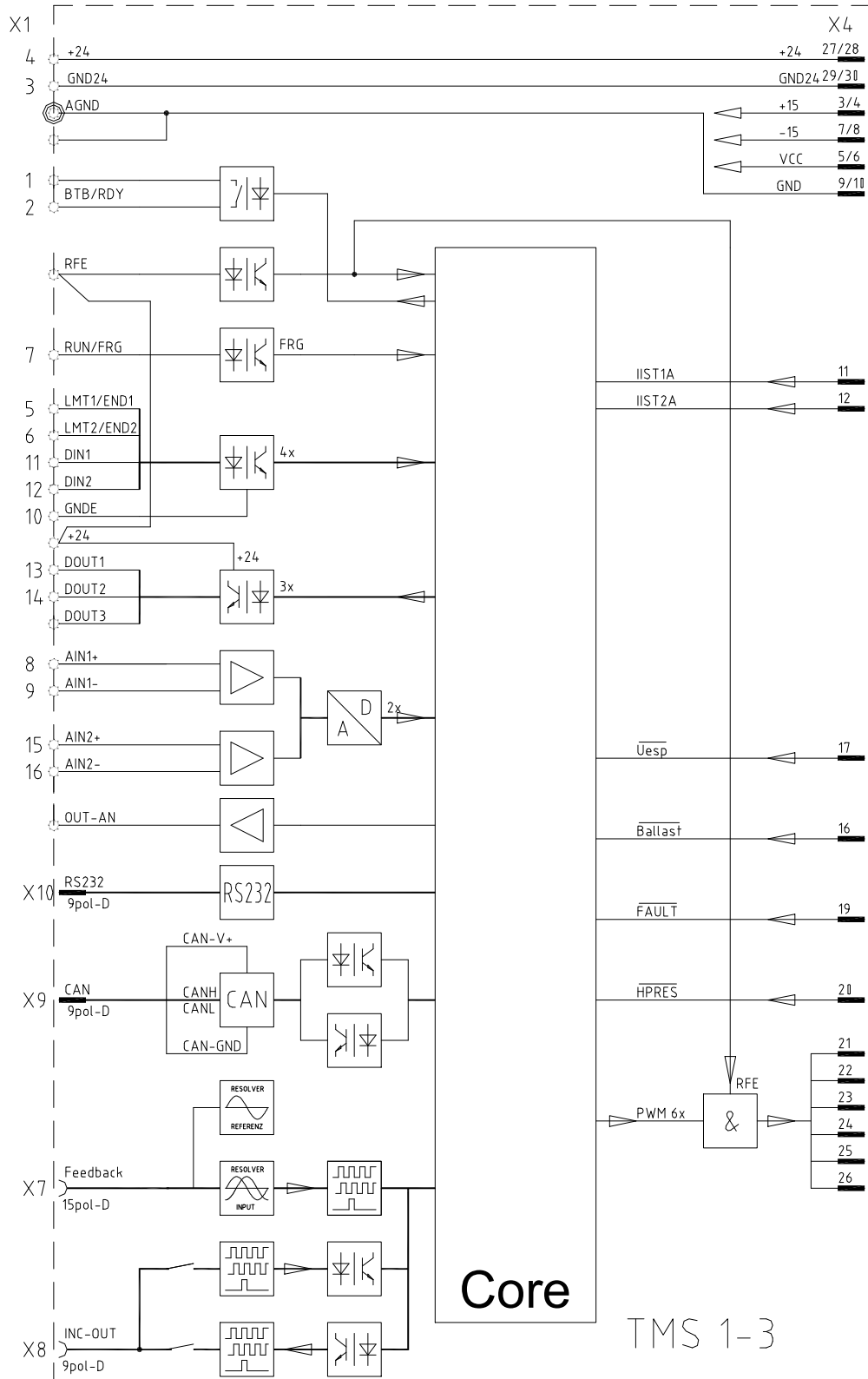

5 Elelectrical Installation

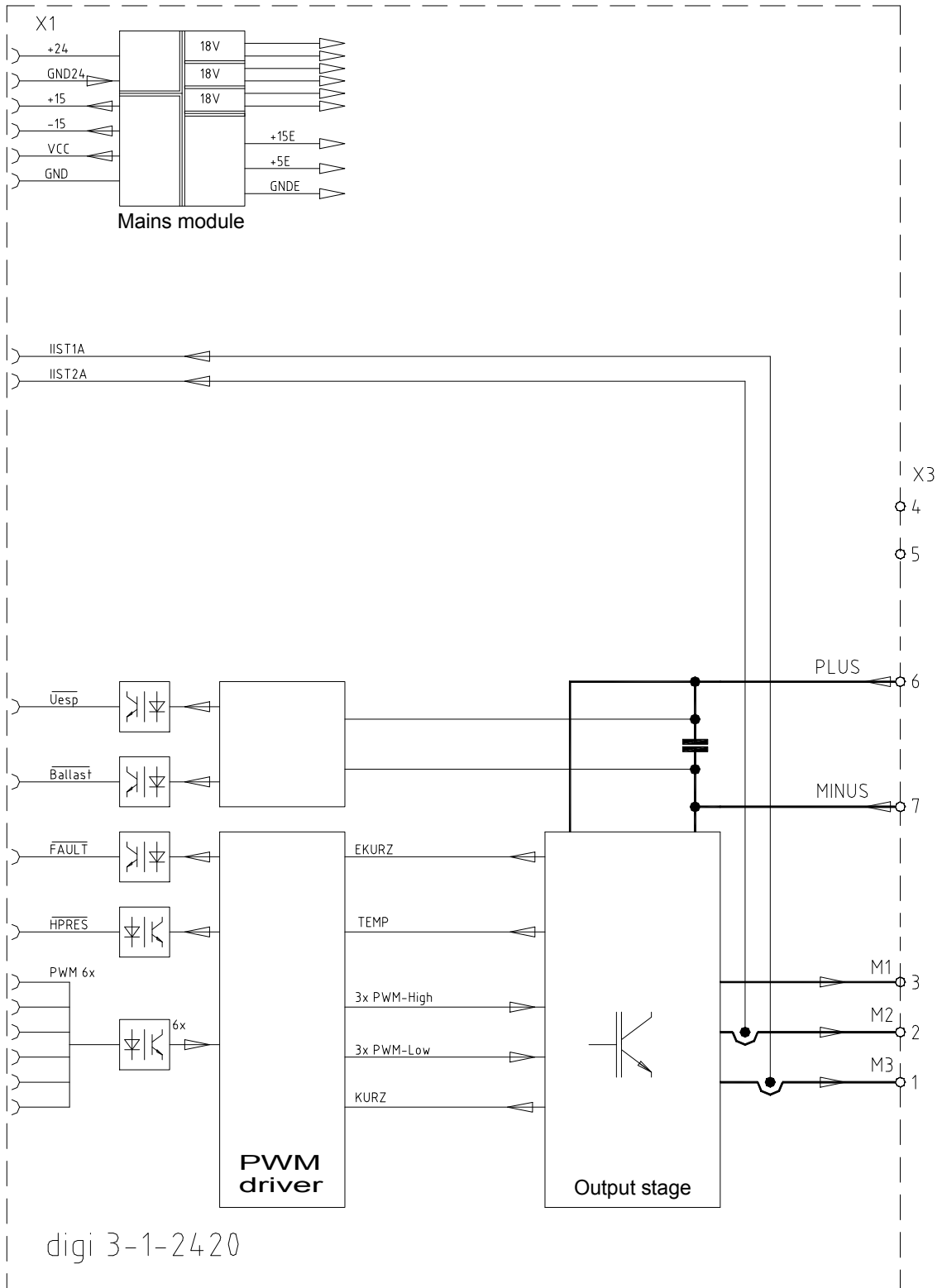

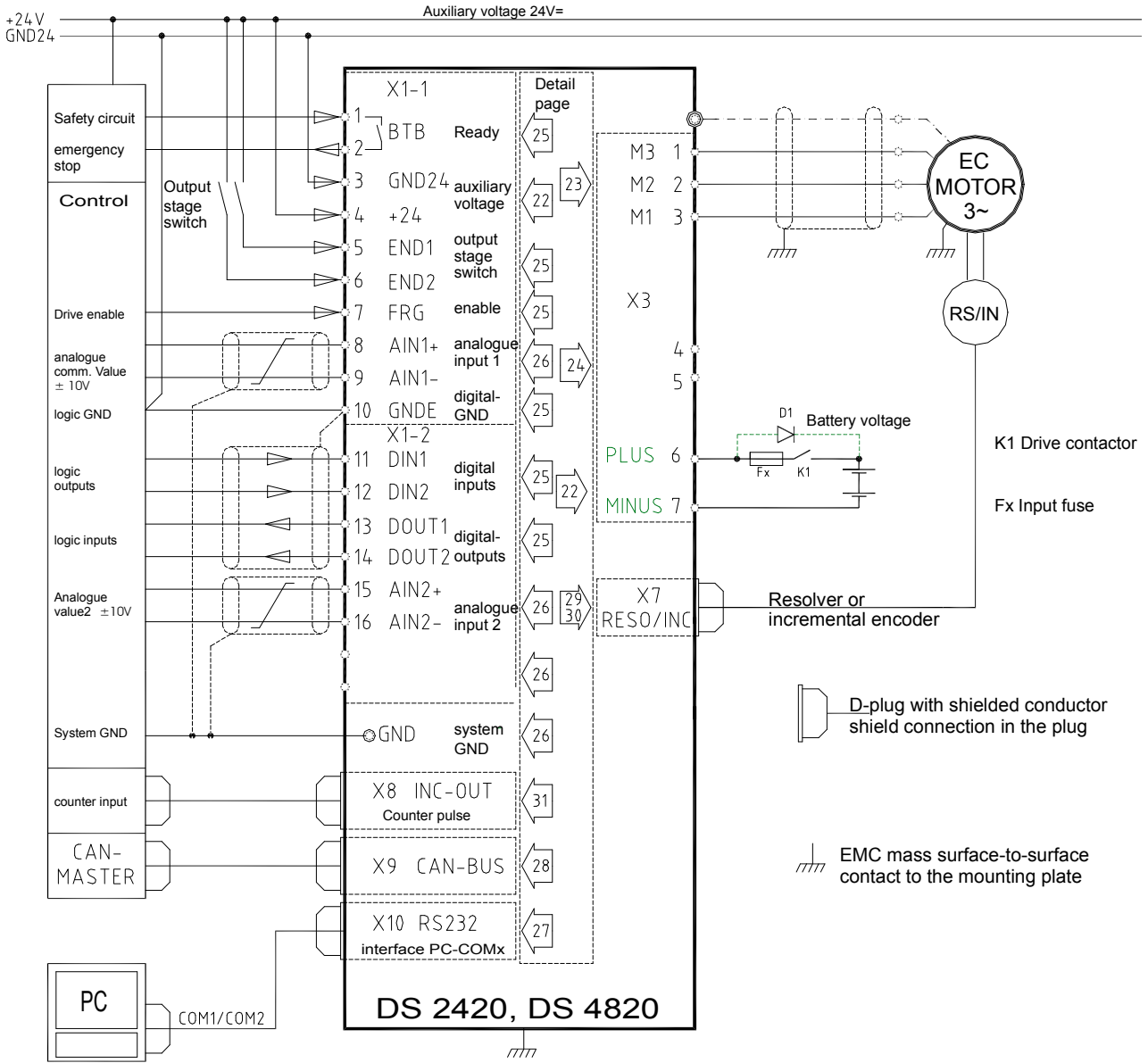

5 Eleectrical Installation

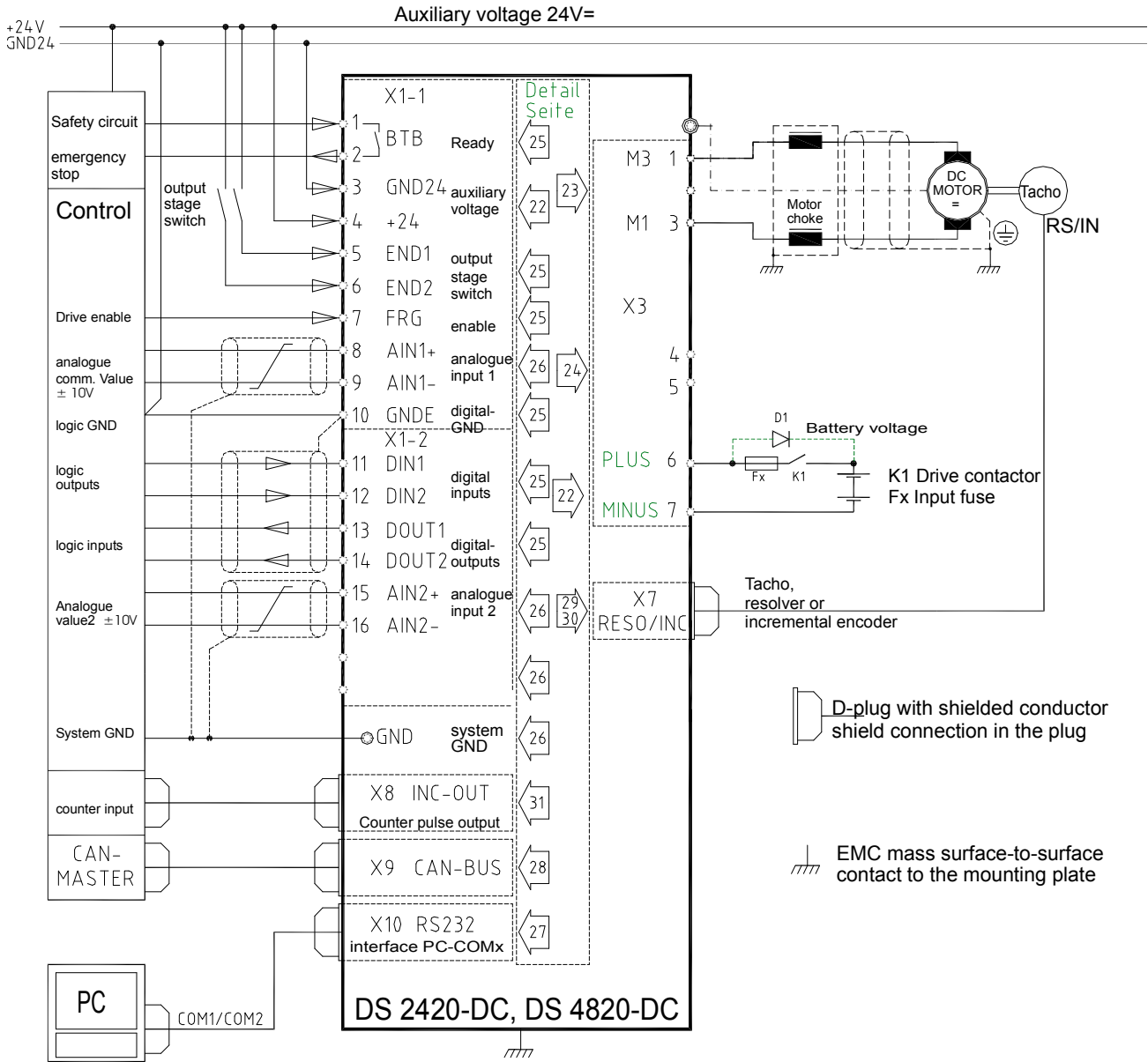

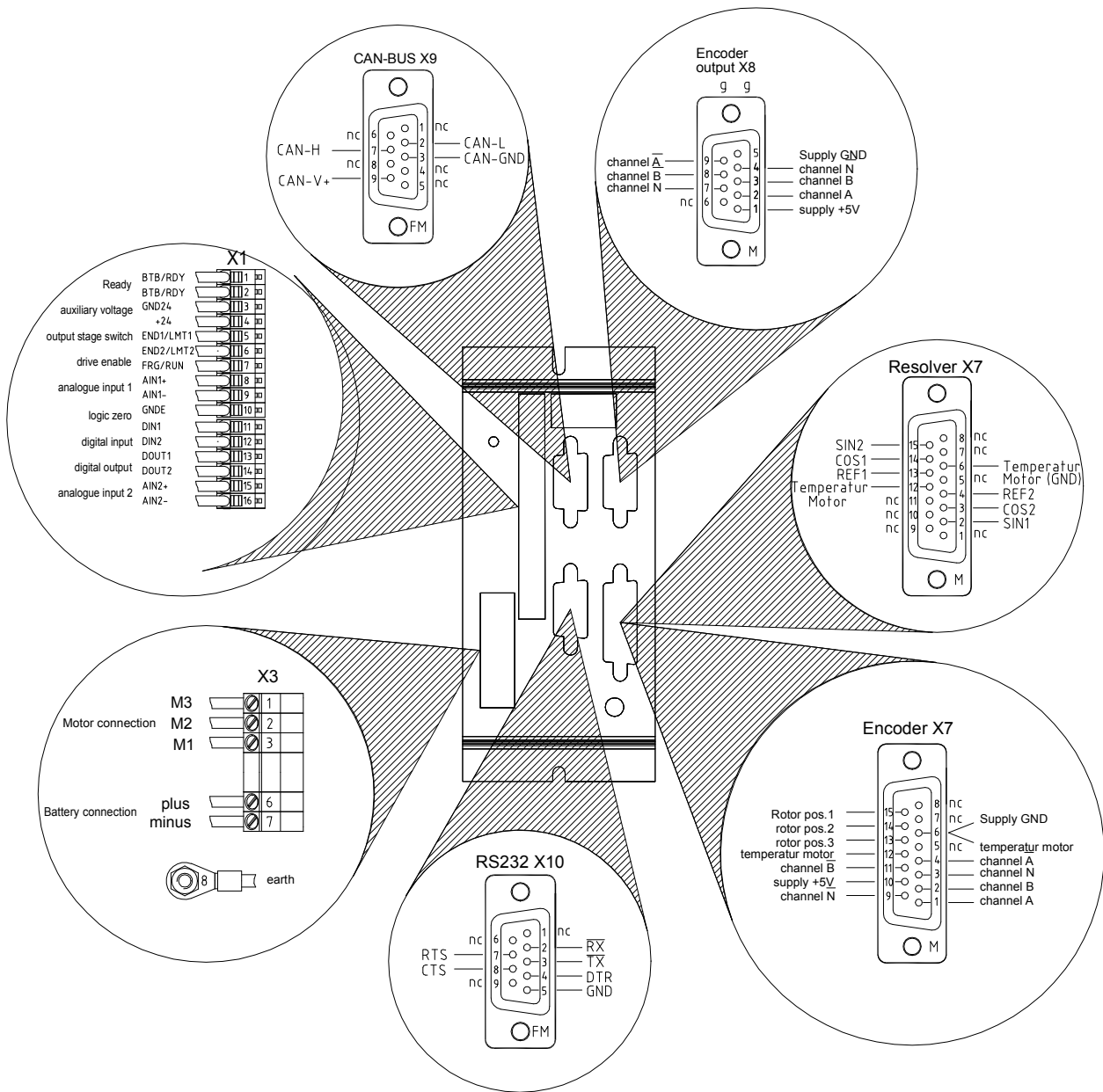

Connector on the solder side
 M = connector
 FM = input jack

5 Eleectrical Installation

Battery connection

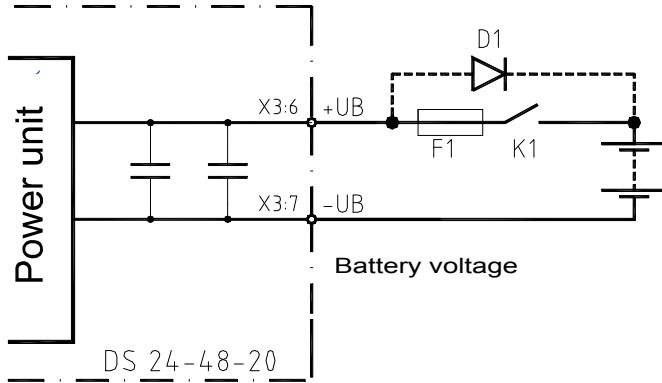

Warning

The max. supply voltage must not be exceeded at any time (not even for short intervals)!



Danger of damage!

F1 = safety fuses

Feedback diode D1

more safety

during braking operation with open contact K1 or defective fuse.



Battery connection

Type	Battery connection	Connection cross - section mm ² AWG		Fuse AT	Drive contactor size
2420	positive - X3:6 negative - X3:7	2.5	14	30	
4810		1.5	16	20	
4820		2.5	14	30	

Eart connection across the earthing point

Auxiliary voltage connection

Mains potential-free auxiliary dc voltage

24V= ±10%/2A

The auxiliary voltage

- is galvanically connected with the logic voltage
- is galvanically isolated from all internal supply voltages of the device
- has internal regenerating fuses
- has an EMC filter

External fuse only for line protection.

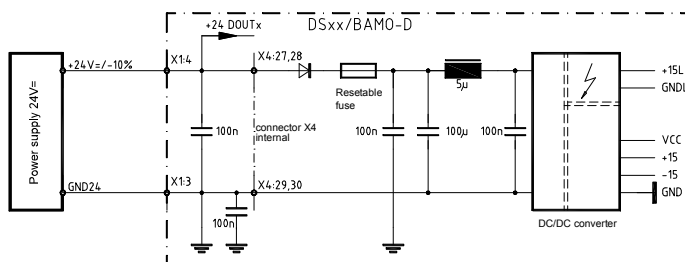

Input voltage 24V dc X1:4
GND24 X1:3

Residual ripple 10%

Switch-on current 2A

Nominal current 0.8A

Mains module: negative connection across earth.

Motor power connection

Only electronically commutating synchronous motors (brushless dc motors, EC motors) with resolver or incremental encoder must be used. These motors must be approved of by UNITEK prior to any use.

See appendix A

(Motor specific connection and parameter standards and guidelines).

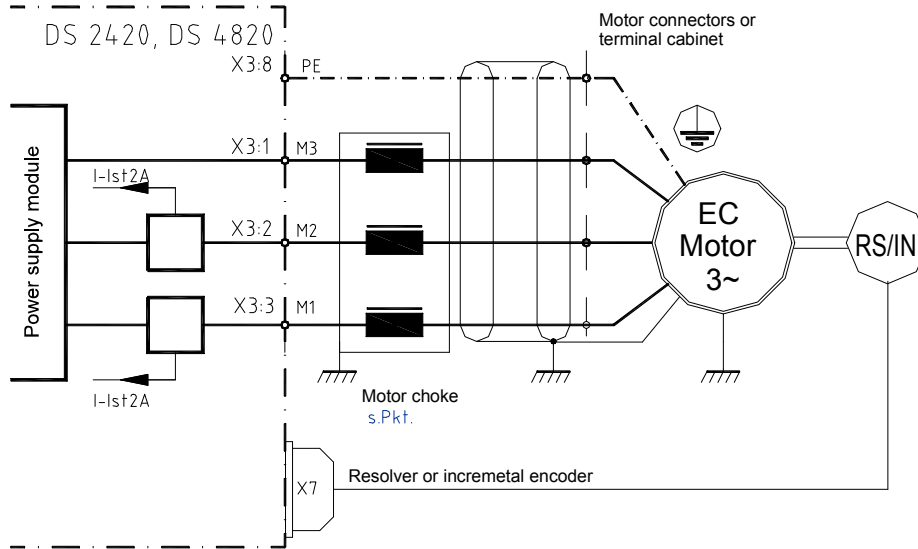

Cable	PE	M1	M2	M3
Connect. terminal	X3:6	X3:3	X3:2	X3:1
Only one correct connecting sequence is possible!				

Type DS	2420	4820
Querschnitt mm ²	2,5	2,5
AWG	14	14

Motor cable

3-core + protective earth conductor, single-shielded for 600V~, 1000V=

shield capacity = 150pF/m

min. cross-section see below table

Motor choke

Only necessary for a shield capacity of >5nF. Approx. 25m motor cable

Connection of the shield

Surface-to-surface connection to the switch cabinet input.

Surface-to-surface connection or connection as short as possible to the motor side.

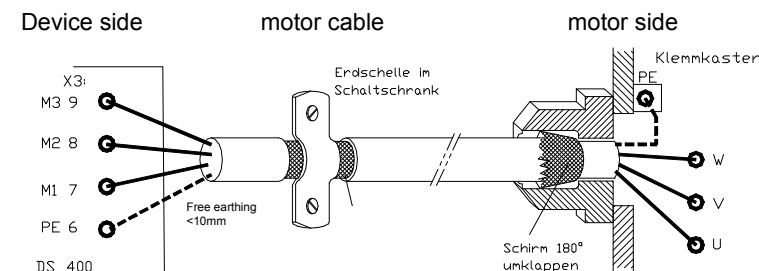

5 Eleectrical Installation

Motor power connection

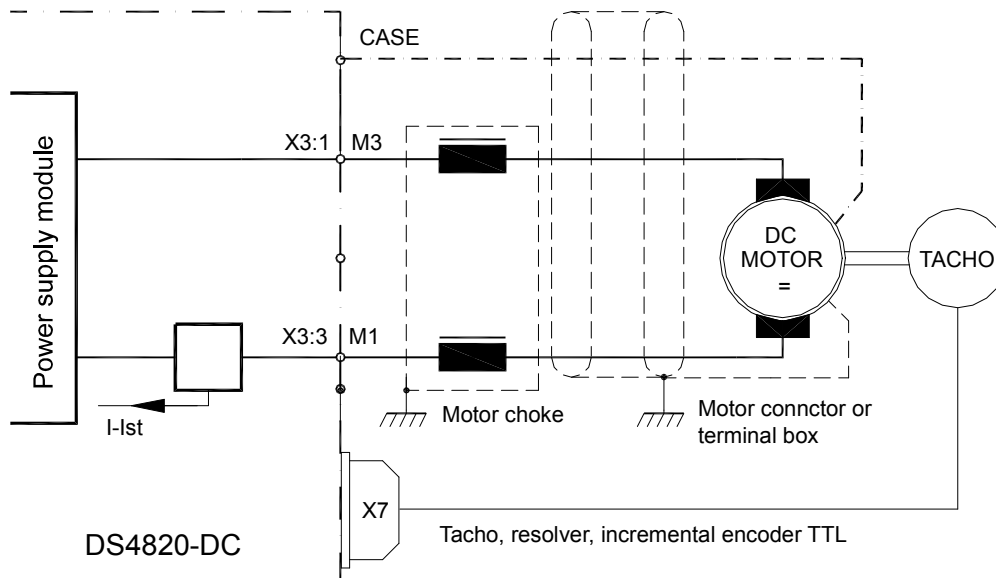

Motor cable

2-core + protective earth conductor
single-shielded for 600V~, 1000V=
shield capacity = 150pF/m

min. Cross-section 2.5mm AWG14

Motor choke

Choke with ferrous motors use forever ! Type 2EI 84-25

Connection of the shield

Surface-to-surface connection to the switch cabinet input.

Surface-to-surface connection or connection as short as possible to the motor side.

Digital inputs

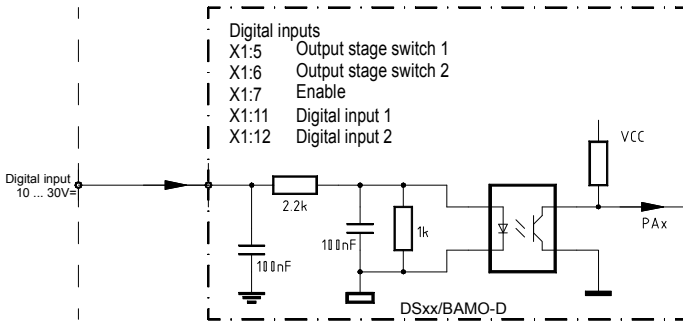

Opto input

Input voltage	+10 to +30V
Level ON	0 to +6V
Level OFF	max. 14mA
Input current	
Nom.voltage/nom.current	+24V/10mA
Ground reference	GNDE (X1:10)

Input	Connection	Function	State 1	State 2	Parameter
FRG/RUN	X1:7	Enable	fixed	fixed	DS-Drive-2 inputs & outputs
END1/LMT1	X1:5	Output stage switch 1	fixed	programmable	
END2/LMT2	X1:6	Output stage switch 2	fixed	programmable	
DIN 1	X1:11	Digital input 1		programmable	
DIN 2	X1:12	Digital input 2		programmable	

Digital outputs

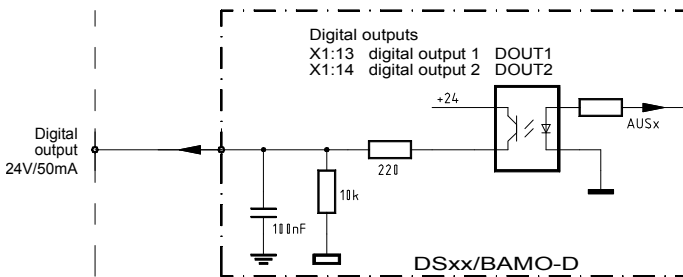

Open emitter output

Output voltage	max. 24V=
Level ON	<1V=
Level OFF	max. 30mA
Output current	220W
Output resistance	+24 (X1:4)
Reference voltage	GNDE (X1:10)
Ground reference	

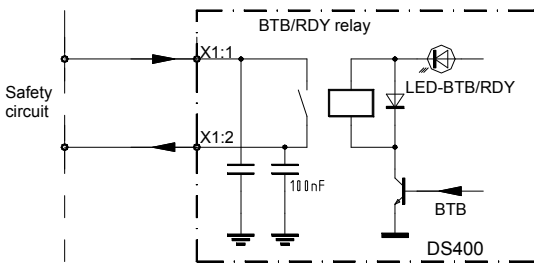

Relay contact

BTB/RDY

Contact for 48V/1A
 The contact is closed when the device is ready.
 Indication by a green LED on the front panel.
 In case of an error the contact is open.



Output	Connections	Function	State	Parameter
BTB/RDY	X1:1, X1:2	ready	fixed /relay	
DOUT1	X1:13	Digital output 1	programmable	DS-DRIVE-2 Inputs&Outputs
DOUT2	X1:14	Digital output 21	programmabler	

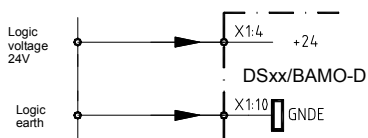

External power supply for the inputs and outputs
 +24V for the logic and the auxiliary voltage
 GNDE logic ground

5 Eleectrical Installation

Analog inputs $\pm 10V$

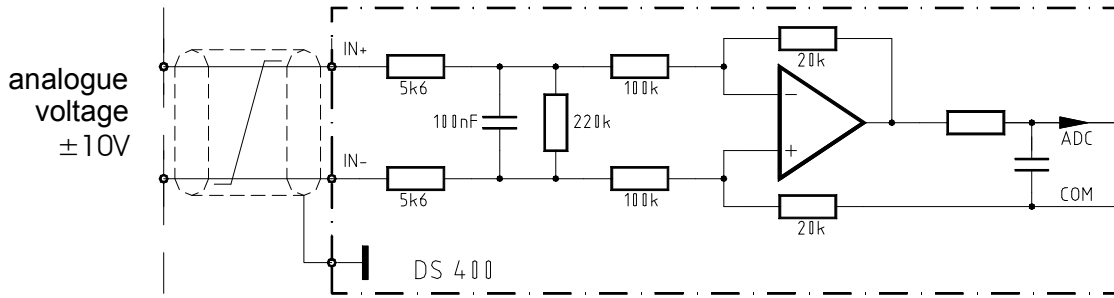

Input	Connection	Basic function	Voltage	State	Parameter
AIN1+,AIN1-	X1:8, X1:9	Speed command value	$\pm 10V$	programmable	DS-DRIVE-2 Analog inputs
AIN2+,AIN2-	X1:15, X1:16	Current limit	$\pm 10V$	programmable	

Features

Differential input	AIN1+/AIN1-	AIN2+/AIN2-	
Input resistance	70k		
Threshold voltage	$\pm 12V$		
Resolution	11Bit + sign		
Parameter scale			
Parameter assignment			

The direction of rotation of the motor can either be changed by swapping the \pm connections at the differential input or by changing the signs via the parameter scale.

RS 232

DSxx is programmed and operated during commissioning via the serial pc interface RS232. There is a software description in the Manual DS.

Connector X10

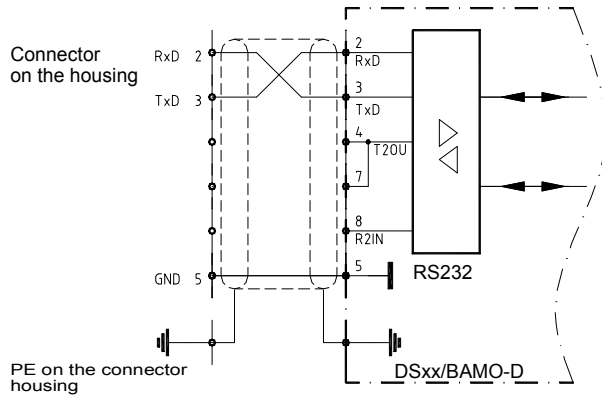

The serial interface is galvanically connected with the device zero (GND).

The DSxx (D connector X10) and the serial interface (COM1/COM2) of the pc must only be connected using a null modem cable.

Do not use a null modem link cable!

Install the cable only after disconnecting the device from the mains.

The interface is hard-coded to 115200Baud.

Null modem connecting cable

View to the soldered side,

Shield on the housing,

Max. cable length 5m

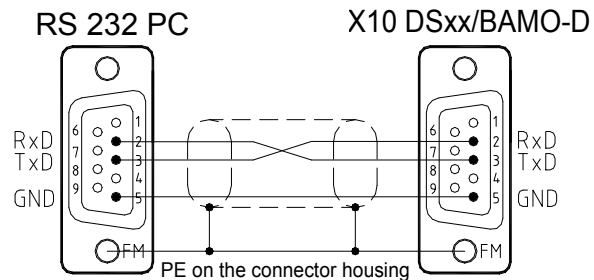

Bei starken Störungen auf der Schnittstelle sollte ein Leitungsfilter eingesetzt werden.

Laptop mit USB-RS232 Konverter sind meist störeffindlich.

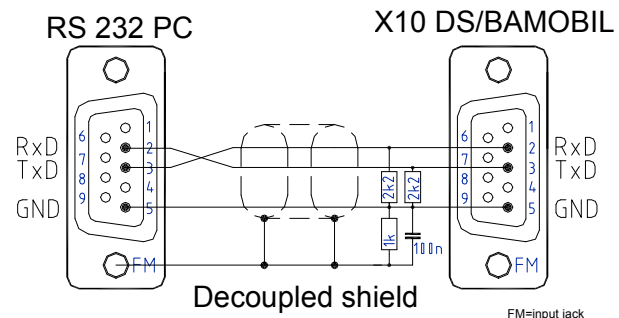

5 Eleectrical Installation

CAN-BUS

The CAN-BUS is a digital connection to the CNC control. Optimum conditions are achieved with LABOD CNC controls. Programming and operation by means of the control panel via the CAN-BUS. Interface complies with the standard ISO 11898.

Adjustment and programming see Manual DS-CAN.

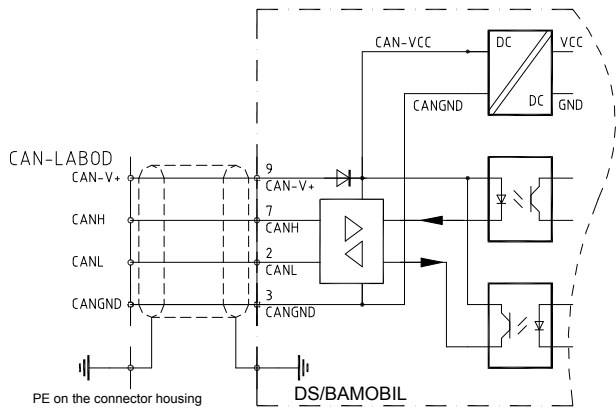

The interface is galvanically isolated from the device. The voltage is supplied via the bus cable. CAN-V+ 9 to 15V=

Option: potentially isolated internal voltage supply

CAN-BUS cable

Use a shielded bus conductor with a low shielding capacity.

Signal + supply.

D-connector with a metal or metallized housing.

Recommended cable colours LiYCY 4x0.25+shield.

Designation	Connector no.	Cable colour	Cable no.
CAN-V+	9	brown	1
CAN-GND	3	white	4 (PE)
CAN-H	7	green	3
CAN-L	2	yellow	2

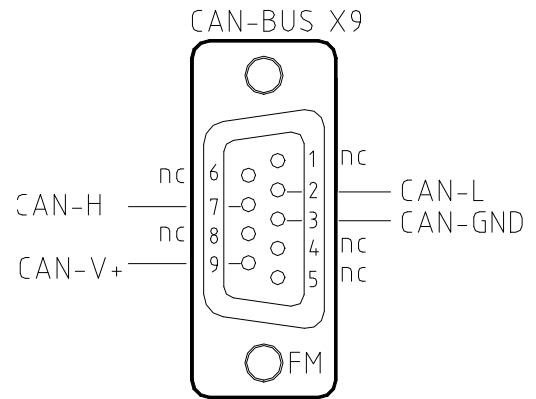

FM=input jack

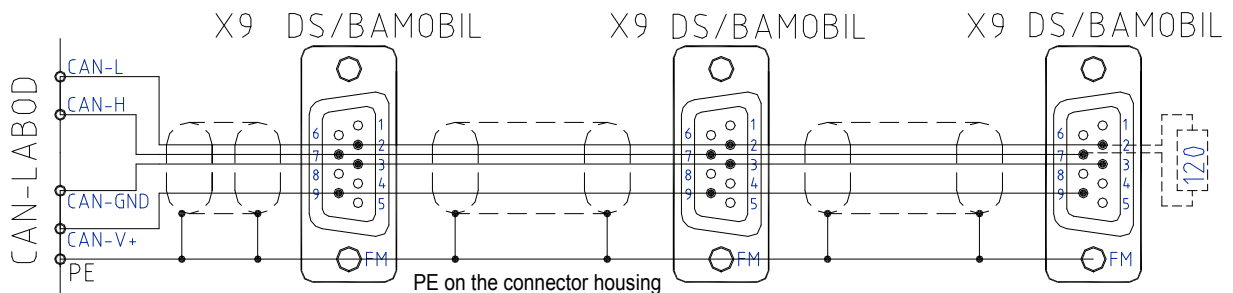

Resolver connection

only for DS 2420, DS 4820-RS

Connector X7

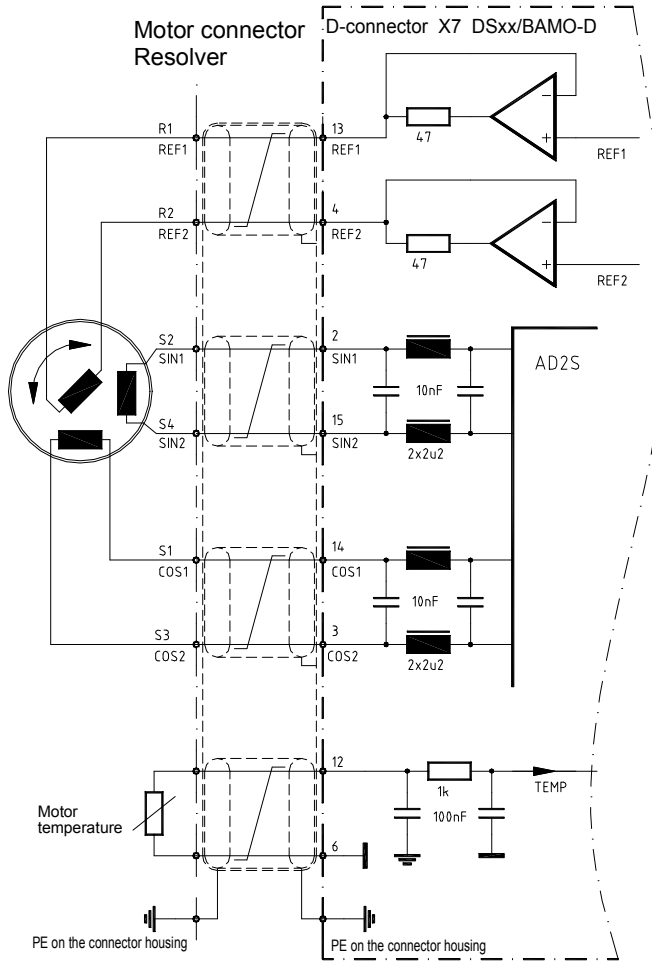

The resolver is an absolute measuring system for a motor revolution.

It is robust and not impaired by high motor temperatures.

Its build corresponds to a revolving transformer.

The rotor is supplied by the reference (10kHz).

The stator supplies the sine and cosine signals modulated by the rotational frequency.

The amplitudes of these signals are analyzed and digitalized in the servo-drive.

The resolution is adjusted to 12 bit (4096 inc/rpm).

The max. possible speed is 15600.

The digitalized signals are used for the polar wheel angle, the position and speed control, and the incremental output.

Die Absolutgenauigkeit ist ca. ± 10 Winkelminuten.

Use only motors with a 2-, 4-, or 6-pole resolver which have been approved by UNITEK (Appendix A).

Observe the motor specific connection data sheet!

Connector
Connecting cable

X7 15-pole D-connector
4 x 2 cores, twisted in pairs and shielded, additional overall shield.

Cable length

For link chains use appropriate cables!
for >25m only use high-quality resolver cables with adequate shielding properties.

Shield connection

across connector X7
combine all shields and connect them to the housing
across the motor the connector housing

Setting parameters

see software Manual DS

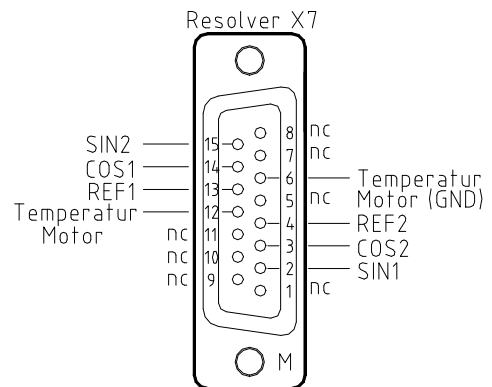

5 Elelectrical Installation

Encoder connection

only for DS 2420, DS 4820-IN

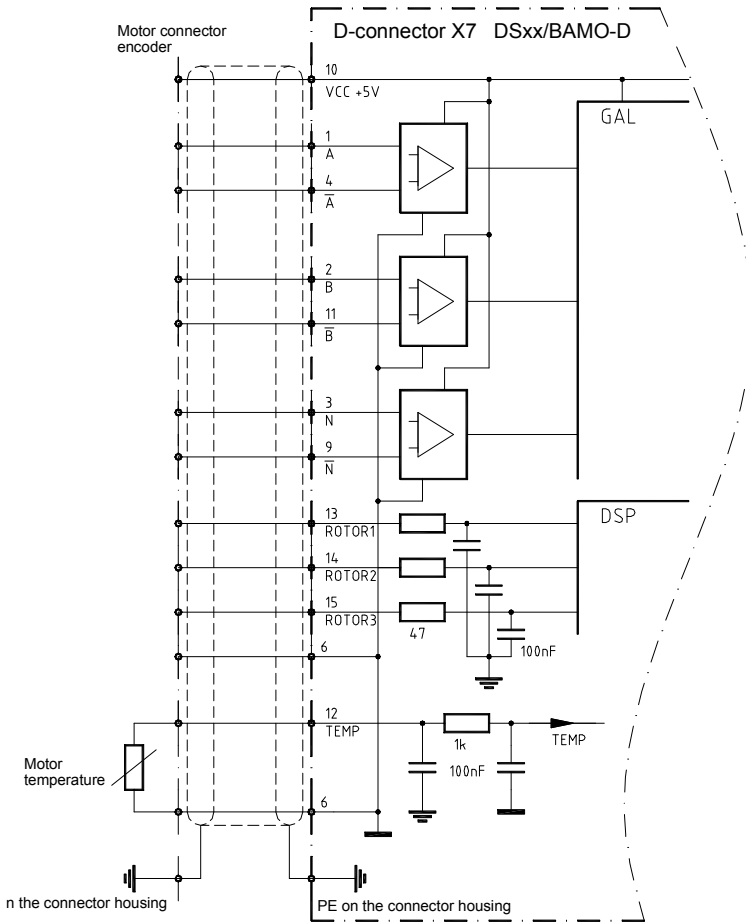

Incremental encoder (encoder) with 2 counter tracks and 1 zero track plus 3 rotor position tracks. Counter tracks with push-pull output.

Only binary numbers

512, 1024, 2048, 4096

The counter input corresponds to RS485.

Max. counting frequency 500kHz.

The incremental encoder is galvanically connected with the device zero (GND).

Supply voltage 5V.

Use only motors with incremental encoders which have been approved by UNITEK (Appendix A). Observe the motor specific connection data sheet!

Steckerbelegung Lötseite

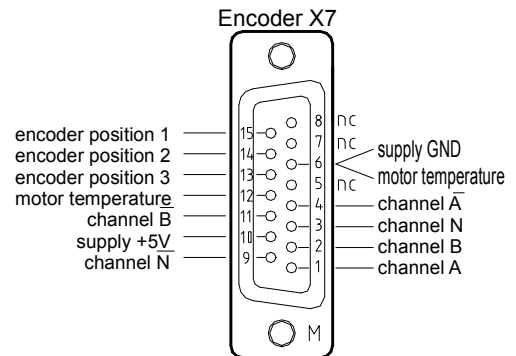

Use only motors with a Incremental (encoder) which have been approved by UNITEK (Appendix A).

Observe the motor specific connection data sheet!

Connector X7 15-pole D-connector

Connecting cable 10 signal conductors, shielded, min. cross-section 0.14mm
2 supply lines, min. cross-section 0.5mm

For link chains use appropriate cables!

Cable length for >25m the cross-section of the cable used must be increased by one grade

Shield connection across connector X7 - connect the shield to the connector housing

Setting parameter across the motor connector-connect the shieldconnector housing
see software Manual DS

SIN / COS Connection

only for DS xx-SC

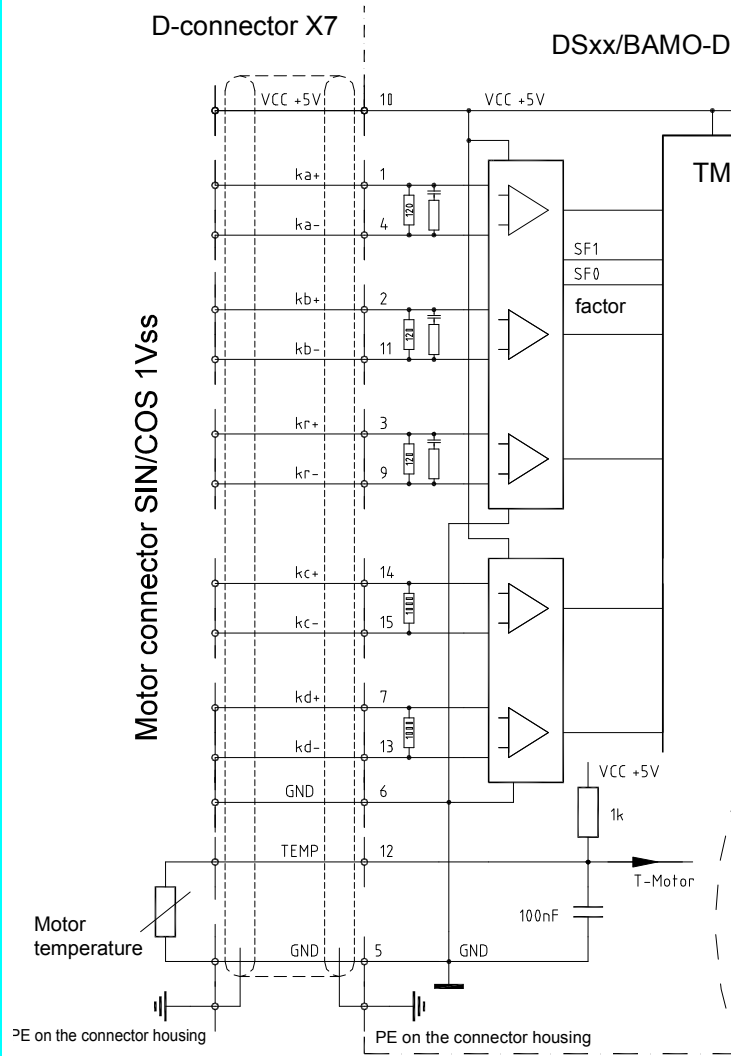

Incremental encoder with 2 analog sinusoidal counter tracks and 1 zero track plus 2 commutating tracks.
Differential inputs 1Vss

Max. counting frequency 500kHz

The incremental encoder is galvanically connected with device zero (GND).
Supply voltage 5V, provided by the servo.

The resolution is automatically adjusted to an optimum.

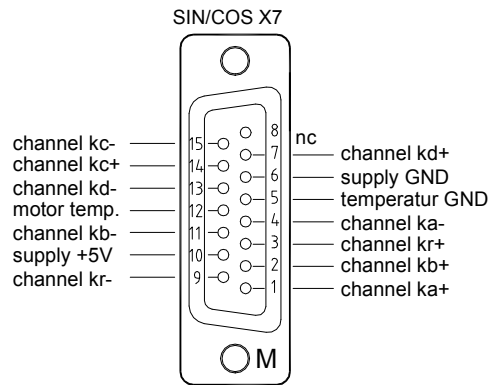

Use only motors with SIN/COS encoders (SC) which have been approved by UNITEK (Appendix A). Observe the motor specific connection data sheet (SC)!

Connector X7 15-pole D-connector

Connecting cable 4 signal conductors, twisted and shielded, min. cross-section 0.14mm
2 signal conductors, shielded, min. cross-section 0.14mm
4 supply lines, temp., min. cross-section 0.5mm

Cable type (4x(2x0.14)+(4x0.14)C+4x0.5)C

For link chains use appropriate cables!

Cable length for >25m the cross-section of the cable used must be increased by one grade

Shield connection across connector X7-connect the shield to the connector housing
across the motor connector - connect the shield to the connector housing

5 Elelectrical Installation

SIN / COS Connection

only for DS xx-SC

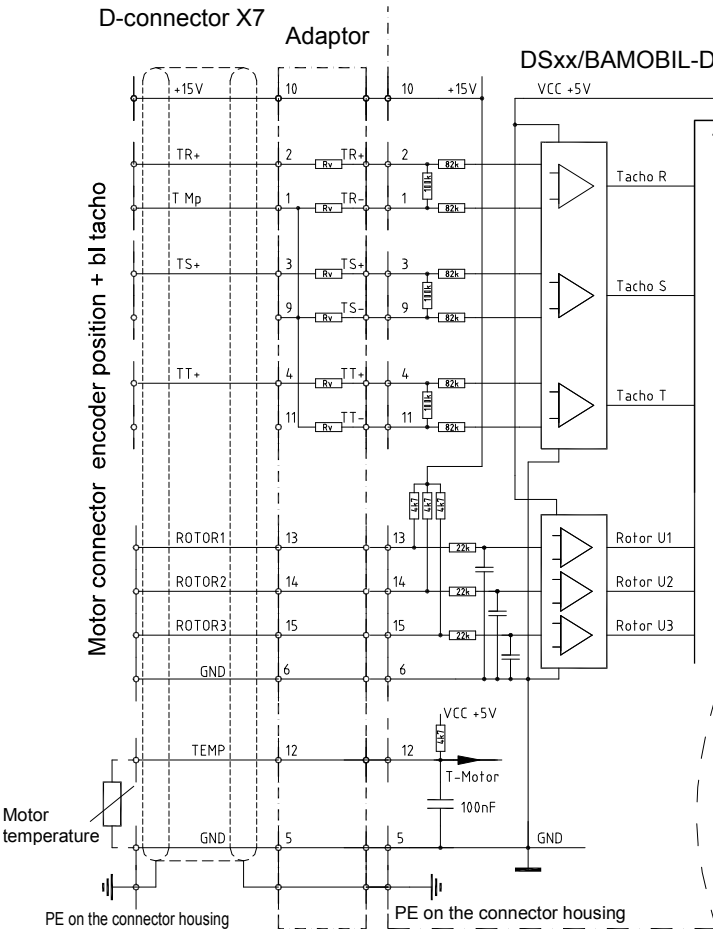

Incremental encoder (Encoder) with 2 analog sinusoidal counter tracks and 1 zero track plus 2 commutating tracks. Differential inputs 1Vss

Max. counting frequency 500kHz

The incremental encoder is galvanically connected with device zero (GND). Supply voltage 5V, provided by the servo.

The resolution is automatically adjusted to an optimum.

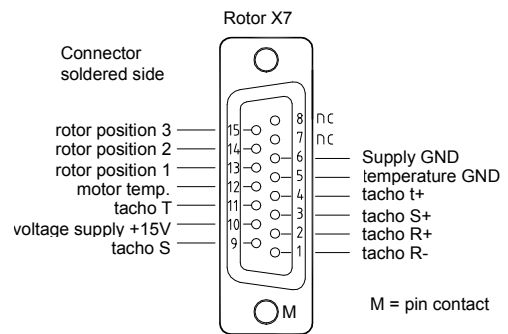

Encoder position

Use only motors with SIN/COS encoders (SC) which have been approved by UNITEK (Appendix A). Observe the motor specific connection data sheet (SC)!

Connector X7 15-pole D-connector

Connecting cable 4 signal conductors, twisted and shielded, min. cross-section 0.14mm
 2 signal conductors, shielded, min. cross-section 0.14mm
 4 supply lines, temp., min. cross-section 0.5mm

Cable type (4x(2x0.14)+(4x0.14)C+4x0.5)C
 For link chains use appropriate cables!

Cable length for >25m the cross-section of the cable used must be increased by one grade

Shield connection across connector X7-connect the shield to the connector housing
 across the motor connector - connect the shield to the connector housing

X8 TTL- Encoder output or input (2)

The D connector X8 is connected as input or output (default).

Output X8 pin 6 not connected or bridge to GND

Input X8 pin 6 bridge to +5V (X8:1)

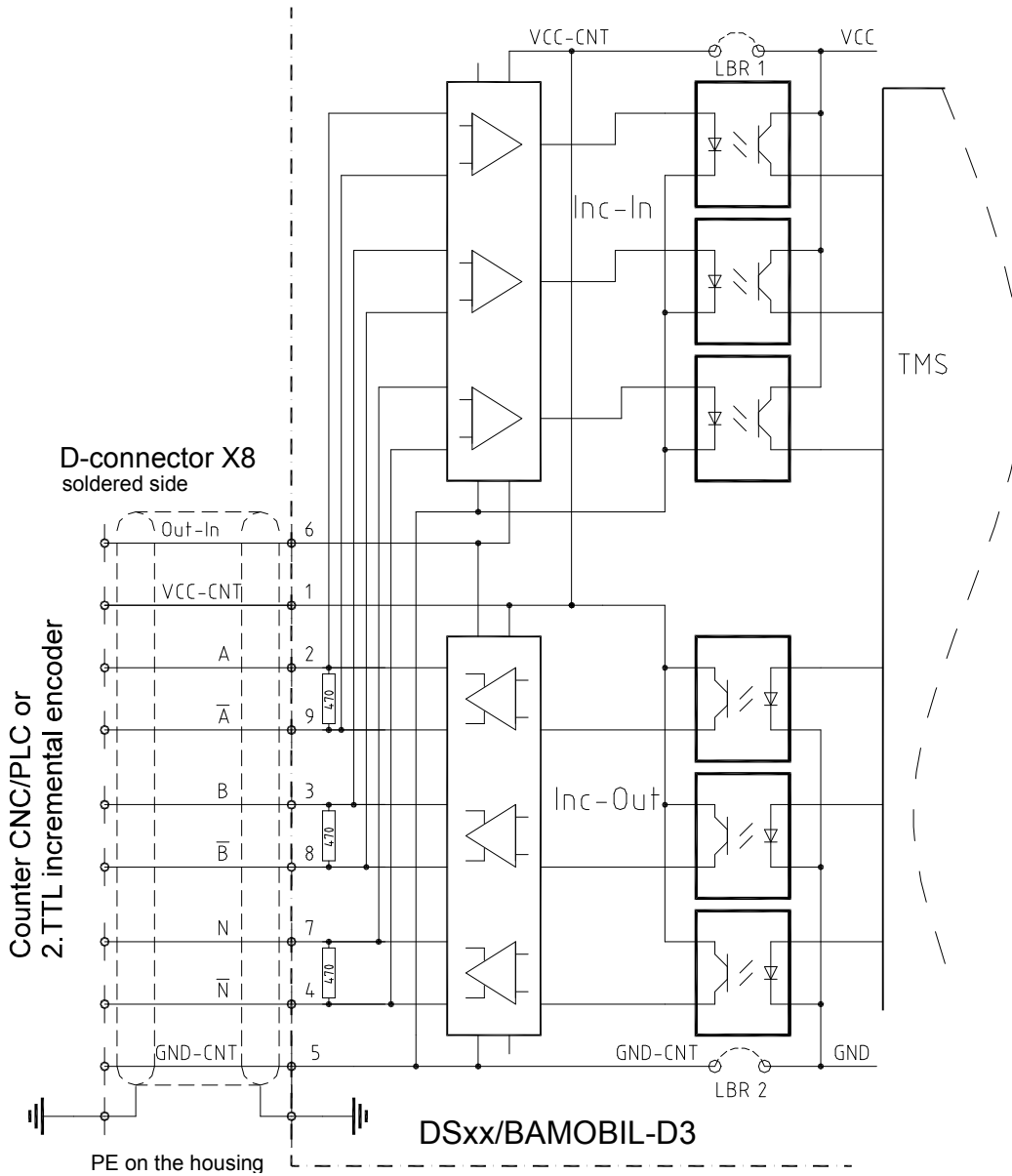

Encoder IN-OUT X8

9-pin D connector (M, pins)

Connector assignment

soldering side

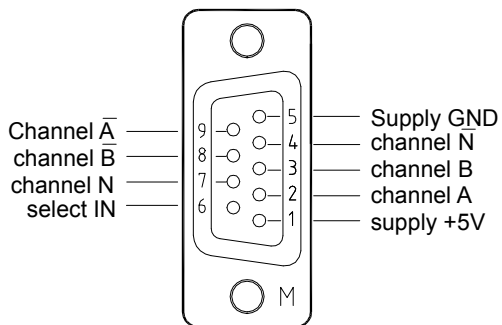

Attention: X8 as input

X8:6 (Select IN) with X8:1 (+5V) connect with the D connector

5 Eleectrical Installation

X8 as TTL Encoder output

The encoder signals supplied by the motor (feedback) are available at the output of the D-connector X8 for the CNC control.

The encoder output is internally isolated.

The voltage is supplied via the encoder line from the CNC/PLC control.

Voltage supply +5V \pm 0.2V.

The output signal corresponds to RS485.

Option: Internal supply from the servo (LBR1 + LBR2)

For RS and SC the resolution can be programmed (parameter 0xa4), Bit1).

For IN it is equal to the number of encoder pulses.

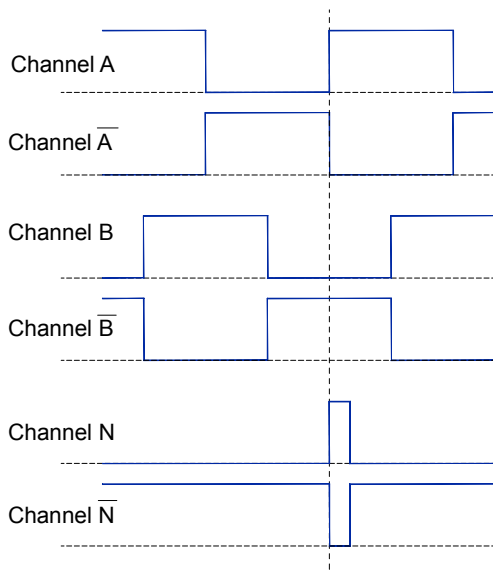

Signals	(motor clockwise rotation)
output level	low < 0.5V high > 4.5V
slope	< 0.1 μ s
zero impulse	min. 0.2 μ s
output frequency	max. 200 kHz
impulse / UPM for RS, SC for IN	programmable number of encoder pulses

X8 as TTL Encoder input

Attention: X8 pin6 (select IN) and X8 pin1 (+5V) must be bridged!

The encoder input is internally isolated.

The voltage is supplied via the encoder line.

Option: Internal supply from the servo

The input signals correspond to RS485.

Input frequency: max. 200kHz

Option: Internal supply from the servo (LBR1 + LBR2)







The encoder input can be programmed to fulfill different functions.

LED displays on the Servo

The operating state “**normal**” is signalled by a bright green seven-segment display + decimal point (display of the state).

The state “**fault**” is signalled by a bright red fault LED and the seven-segment display indicates the error no.

Display of the servo-drive state

Display	Point/segment	State	State of NDrive
	flashing	Processor active	
	dark	Auxiliary voltage missing or inherent hardware failure	
	flashing	Starting state after reset (auxil. voltage 24V off-on). The first enable stops the flashing display.	OK = 0
	bright	Drive enabled	OK = 1, ENA = 1
	dark	Drive disabled (not enabled)	OK = 1, ENA = 0
	bright	Speed zero (standstill signal)	N0 = 1
	bright	Drive revolves clockwise, N currently positive	N0 = 0
	bright	Drive revolves anti-clockwise, N currently negative	N0 = 0
	flashing	Motor current reduced to continuous current I_{cns}	$I_{cns} = 1$
	bright	Motor current at max. current limit I_{max}	$I_{cns} = 0$
	dark	Normal operation; Motor current within the current limits	$I_{cns} = 0$
	bright for 0.1s	A new command (value) was received from the BUS or RS232	

Example: Motor revolving clockwise

- Point flashes = active processor
- bottom segment = drive enabled
- right segment = motor revolves clockwise

5 Eleectrical Installation

Error message on the Servo

In case of an error the red LED 'fault' lights up and the green 7-segment display indicates the error number.

Error list

Display on the Servo	Error message on the NDrive	Description
0	BADPARAS	Parameter error
1	POWER FAULT	Output stage error
tx108602	RFE FAULT	Error in the safety circuit
3	BUS TIMEOUT	Transfer error BUS
4	FEEDBACK	Incorrect/faulty encoder signal
5	POWERVOLTAGE	No power supply voltage
6	MOTORTEMP	Motor temperature too high
7	DEVICETEMP	Device temperature too high
8	OVERVOLTAGE	Over voltage >1.8 x UN
9	I_PEAK	Overcurrent 300%
A	RACEAWAY	Racing (without command value, incorrect polarity)
B	USER	User's error choice
C	RESERVE	
D	RESERVE	
E	CPU-ERROR	Software error
F	BALLAST	Ballast circuitry overload
Flashing decimal point	Active processor	
Dark decimal point	Missing auxiliary voltage or device hardware failure	

Example:



FAULT LED
Error no. 5

red
Power voltage (missing power voltage)

Guarantee

UNITEK guarantees that the device is free from material and production defects. Test results are recorded and archived with the serial number.

The guarantee time begins from the time the device is shipped, and lasts one year. Unitek undertakes no guarantee for devices which have been modified for special applications.

During the warranty period, UNITEK will, at its option, either repair or replace products that prove to be defective, this includes guaranteed functional attributes. UNITEK specifically disclaims the implied warranties or merchantability and fitness for a particular purpose. For warranty service or repair, this product must be returned to a service facility designated by UNITEK.

For products returned to UNITEK for warranty service, the Buyer shall prepay shipping charges to UNITEK and UNITEK shall pay shipping charges to return the product to the Buyer.

However, the Buyer shall pay all shipping charges, duties, and taxes for products returned to UNITEK from another country.

The foregoing warranty shall not apply to defects resulting from:

- * improper or inadequate repairs effected by the Buyer or a third party,
- * non-observance of the manual which is included in all consignments,
- * non-observance of the electrical standards and regulations
- * improper maintenance
- * acts of nature

All further claims on transformation, diminution, and replacement of any kind of damage, especially damage, which does not affect the UNITEK device, cannot be considered. Follow-on damage within the machine or system, which may arise due to malfunction or defect in the device cannot be claimed.

This limitation does not affect the product liability laws as applied in the place of manufacture (i. e. Germany).

UNITEK reserves the right to change any information included in this MANUAL.

All connection circuitry described is meant for general information purposes and is not mandatory.

The local legal regulations, and those of the Standards Authorities have to be adhered to. UNITEK does not assume any liability, expressively or inherently, for the information contained in this MANUAL, for the functioning of the device or its suitability for any specific application.

All rights are reserved.

Copying, modifying and translations lie outside UNITEK's liability and thus are not prohibited. UNITEK's products are not authorised for use as critical components in the life support devices or systems without express written approval.

The onus is on the reader to verify that the information here is current.