

MANUAL

Digital Servo Controller DS400.2

for

EC Servo Motors AC Induction Motors DC-Servo-Motors



UNITEK | Industrie Elektronik
G m b H

Hans-Paul-Kaysser-Strasse 1
D-71397 Leutenbach 3 - Nellmersbach

Tel.: 07195/9283-0
Fax 07195/928329
email info@unitek-online.de
Http// www.unitek-online.de

Ausgabe 0211-V11

Contents

Part 1 Hardware-Manual

| | Contents | Page |
|----------|-----------------------------------|-------------|
| 1 | Basis-Information | |
| 1.1 | Safety instructions | 3,4 |
| 1.2 | General | 5 |
| 1.3 | Application | 6 |
| 1.4 | Construction | 74 |
| 1.5 | Technical data | 8,9,10 |
| 2 | Mechanical Installation | |
| | Important instructions | 11 |
| 2.1 | Dimension DS 400 | 12 |
| 2.2 | Dimension Frontpanel | 13 |
| 2.3 | Dimension Accessories | 14 |
| 2.4 | Assembly | 15 |
| 3 | Electrical Installation | |
| | Important instructions | 16 |
| 3.1 | Block diagram | 17,18 |
| 3.2 | Connection diagram | 19,20,21,22 |
| 3.3 | Connectors | 23,24 |
| 3.4 | EMC | 25 |
| 3.5 | Power supply | 27,28 |
| 3.6 | Auxiliary voltage connection | 29 |
| 3.6 | Motor connection | 30 |
| 3.7 | Regen resistor | 31,32 |
| 3.8 | Control signals | 33,34,35,36 |
| 3.9 | RS232 | 37 |
| 3.10 | CAN-BUS | 38 |
| 3.11 | Resolver | 39 |
| 3.12 | TTL-Encoder | 40 |
| 3.13 | SIN / COS 1Vss | 41 |
| 3.14 | Rotor, bl-Tacho | 42 |
| 3.15 | Encoder- Output, 2.Encoder -Input | 43,44 |
| 3.16 | LED-Anzeigen | 45,46,47 |
| 4.0 | Optionen | 48 |
| 5.0 | Guarantee | 49 |
| Part 2 | Software -Manual NDrive | |
| Part 3 | Commissioning | |
| Part 4 | CAN-BUS reference | |

Free



Electronic devices are never fail-safe.

Caution: High voltage DC 900V=.

**Electric shock hazard!
Danger to personnel!
DC-BUS discharge - time >4min**

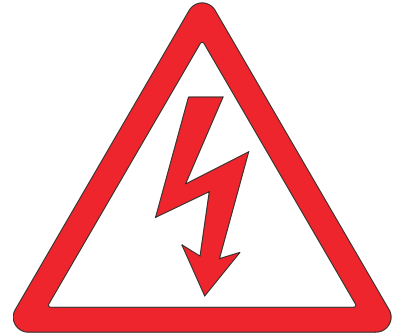

This manual must be carefully read and understood by the professional prior to installation or start-up.

Consult the manufacturer or the dealer if anything is unclear.

Faulty installation can lead to destruction of the devices.

The DS xx series devices are electrical resources (EB) for power electronics regulating electric currents.

They are designed to control EC synchronous motors (brushless dc motors, BLDC) in industrial applications.

IP20 protection standard for cabinet-mounting.

Only connect to earthed mains or an earthed three-phase network.

Regulations and guidelines:

Mount and connect the devices and their appropriate components in compliance with technical regulations locally applicable and required by law:

- EG-guidelines 2004/108/EG, 2006/95/EG, 2006/42/EG
- EN60204-1, EN292, EN 50178, EN60439-1, EN61800-3, ECE-R100
ISO 6469, ISO 26262, ISO 16750, ISO 20653, ISO 12100
- IEC/UL IEC 61508, IEC364, IEC 664, UL508C, UL840
- VDE-regulations VDE 100, VDE 110, VDE 160 und
- TÜV-regulations
- Trade association regulations, VGB4

**Do not operate unless the control cabinet is closed or secured.
Control and power connections can be live even though the drive
is inoperative.**

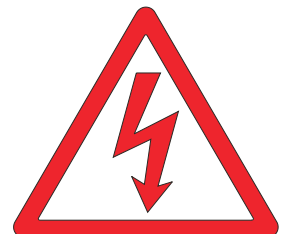

**The DC-BUS discharge time is more than 4 minutes.
Measure the voltage prior to dismantling!**

The user must ensure:

- that when the unit fails
 - when an operator error occurs,
 - when the controlling and control units fail, etc..
- the drive homes to a safe operating state.



Apart from that machines and installations must be provided with monitoring and safety systems independent from the unit. Danger to man and property must be impossible to incur!

Assembly work

- only if all power is cut
- only by qualified professionals

Installation work

- only if all power is cut
- only by qualified electrical professionals
- Comply with safety regulations

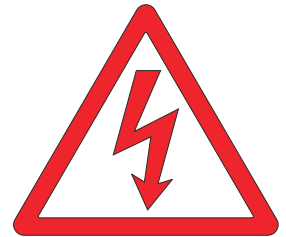

Setting and programming work

- only by qualified professionally specialised in electronic drives and software
- observe programming notes
- Comply with safety regulations

CE:

When it is mounted in machines and installations the proper operation of the unit is not permitted until the machine or installation has been approved according to the regulations of the EC machine directive 2006/42/EG, and the EMC directive 2004/108/EG .

Die EC directive 2004/108/EG plus the EMC standards EN61000-2 and EN61000-4 are complied with in the EMC Notes chapter specified installation and test conditions.

A manufacturer’s certificate is available.

The manufacturer of the machine or the installation is responsible for the observance of the threshold values prescribed in the EMC regulations..

QS

Based on their serial number and test data the units are archived by the manufacturer for 5 years.

The test certificates are available on request.

Safety symbols



Attention danger to life
High voltage



Attention
Important
Warning

A feature of the digital three-phase servo amplifier DS xxx and the brushless d.c. motor (synchro servomotor, EC motor) drive unit is that it is maintenance-free and has high control dynamics.

The drive exhibits the known good control characteristics of d.c. drives without the disadvantages of carbon brush service times and the commutation limit.

The moment of inertia of the rotor is considerably smaller and the maximum power is higher than for d.c. motors of an identical construction. This results in acceleration values that are higher up to a factor of 5.

Compared to asynchronous motors with frequency converters the stability, the control range and the efficiency of the drive are considerably improved.

Since the temperature increase of the motor is only in the stator, the EC motors are always designed to protection degree IP 65.

The brushless d.c. motor is electrically designed as a synchronous motor with a permanent magnet rotor and a three-phase stator.

The physical properties correspond to those of the d.c. Motor, i.e. the current is proportional to the torque and the voltage is proportional to the speed. The speed is controlled stably up to the maximum current (max. torque). When an overload occurs the speed drops and the current remains constant.

Rectangular speed/torque characteristic.

The current, the speed and the position are measured exactly. The rotary field frequency is not a controlled variable, it sets itself automatically.

The motor voltages and currents are sinusoidal. Maximum motor efficiency by compensating current control.

DS 400 can be used as a torque amplifier, a speed amplifier or a single axis position amplifier.

The position and speed actual values are generated from the sensor unit (resolver or incremental encoder). The encoder pulses are emitted from the amplifier for a superposed SPC/CNC control.

The current, speed and position control loops are easily programmable digital PID controllers. Programming is at a PC or a programming box.

Communication with superposed controls through BUS systems (standard CAN-BUS, RS232) or through an analog interface.

Caution:

For DC-BUS fed DC, AC or bl servo amplifiers in the braking mode it is necessary to take into account the power reverse feed in the DC-BUS. (lifting drives, unwinders, great flywheel masses)

External regenerative circuit discharge resistor.

Information:

Other products

Digitale Controller for low power

Analog EC/AC Servo-Controller

Analog DC-Servo-Controller

Thyristor-Controllers 1Q,4Q,Servo

DC und AC Servo-Controller for Batterie drive analog and digital

>>> UNITEK DS205, DS403

>>> UNITEK Serie TVD3, TVD6, AS

>>> UNITEK Serie TV3, TV6, TVQ6

>>> UNITEK Serie Classic
200W bis 800kW

>>> UNITEK Serie BAMO A2, A3, D3
Serie BAMOBIL

Application in:

All types of machines and installations up to a drive power of 30kW.

Especially as

4Q- servo drives in feed axes, for highly dynamic acceleration and braking applications, for large control ranges,

for high efficiency,

for small motor dimensions,

for an even and smooth travel.

For speed and torque regulation or combined speed and torque regulation with or without a superimposed position controller.

Constant drives for hoisting equipment, spindle drives, pumps, transverse and longitudinal slitting drives, multi-motor parallel drives. Synchro –servo drives are compacter than other electrical drives.

For use in:

Insertion machines, testing machines, sheet-metal working machines, machine tools,

machines for the plastics industry, automatic assembly machines, knitting and sewing

machines, textile machines, grinding machines,

wood and stone working machines, metal working machines, XY tables, machines for the

food industry, robot and handling systems, rack feeders, extruders, calenders and

also in many other machines and installations

The motors are:

designed for protection standard IP 65,

compact, for harsh environments,

for a high dynamic overload, maintenance-free

Note:

Braking operation for EC - drives

For example.: Un-reeling machines, hoists, flyweights. The braking energy is dissipated in the regenerative circuit or fed back to the mains via an external inverter.

Caution: The internal regenerative resistors have only a small continuous rating. Calculate the retarding power and use external regenerative circuit discharge resistors if necessary or for design safety. Calculation of regenerative power. See page 31,32



Construction, characteristics:

Cabinet-mounted device in an all-steel housing.
 In compliance with VDE/DIN and EU guidelines. (IP20, VGB4).
 Standard fully-digital regulation electronics.
 Power electronics from 5A to 50A (S1 - operation).
 Power input voltage 30V~ to 480V~.
 Independent 24V - chopper power supply unit for auxiliary voltages.

DC decoupling between:

the housing to all electrical parts
 auxiliary voltage connection to power unit and control electronics,
 power unit and control electronics
 Control electronics and logic inputs.
 The clearance in air and leakage distances comply with VDE.

Used are:

Generously dimensioned, fully insulated IGBT - power semiconductors.
 Only commercially available, industrial standard components,
 SMD - placed,
 LED displays

Characteristics:

- * Direct 30V~ to 480V~ mains connection
- * Independent 24V= auxiliary voltage connection.
- * Digital RS232, CAN-BUS (additional option) interfaces.
- * Analog inputs, programmable differential inputs,
- * Digital programmable inputs/outputs. Opto-decoupled,
- * Enable and limit switch logic,
- * Ready for operation signal BTB, relay contact.
- * Position, speed and torque regulation,
- * Incremental resolver or encoder (optionally a sinus transmitter),
- * Encoder output,
- * Static and dynamic current limit.
- * Standard, fully digital control unit,
- * Intrinsically safe, short-circuit proof power unit,
- * DC-BUS choke (EMC choke),
- * Integrated regenerative discharge circuit,
- * DC power bus.
- * Processor-independent safety switch-off when either the amplifier or the motor have over voltage, under voltage, a short circuit, a line-to-earth fault or excess temperature.

3 Basis - Information

| | | | | |
|----------------------|-------------------|-----------------------------------------|------------------------------------------|----------------------|
| Power supply voltage | to 1kW to 18kW | 1/3x 30V~ to 480V~ 3x 30V~ to- 480V~ | +10% +10% | 50/60 Hz 50/60 Hz |
| Auxiliary supply | 24V= | 10% / 2A | Ripple voltage <10%, self-resttable fuse | |

| Data | Dim. | DS-405 | DS-412 | DS-420 | DS-450 |
|-------------------------------|------------------------------------|-------------|-------------|-------------|-------------|
| Rated supply voltage | V~ | 3x400 (480) | | | |
| Rated output voltage | V~eff | 3x400 (480) | | | |
| DC-link voltage | V= | 560 (675) | | | |
| Rated installed load S1 | kVA | 3,4 | 8.2 | 14 | 34 |
| Rated output load S1. | kW | 3 | 7.5 | 13.5 | 33 |
| Continue current rms | A _{eff} | 5 | 12 | 20 | 50 |
| Peak current | A _{lo} | 10 | 24 | 40 | 100 |
| Dissipation max. | W | 80 | 150 | 250 | 550 |
| Clock frequency | kHz | 8 | | | |
| Level regen circuit | V= | 790 10 | | | |
| Level Over voltage | V= | 890 10 | | | |
| Regen resistor extern minimum | | 100 | 42 | 22 | 10 |
| External fusing integral | A ₂ A ² s | 10 150 | 20 200 | 40 300 | 80 1300 |
| Weight | kg | 3 | 3 | 3.3 | 8 |
| Dimension HxWxD | mm | 320x100x185 | 320x100x185 | 320x100x185 | 320x160x185 |
| Size | | 2 | 2 | 2 | 3 |

| Input / Output | V | A | Function | Connector | |
|-----------------|-----------|-------------|--------------------|-----------|----|
| Analog Input | 10 | 0.005 | Differential input | X1 | |
| Digital input | ON OFF | 10-30 <6 | 0.010 0 | Opto | X1 |
| Digital output | +24 | 0.03 | Opto | X1 | |
| Resolver input | | | Differential input | X7 | |
| Encoder input | >3.6V | | Opto | X7 | |
| Encoder output | >4.7 | | Opto | X8 | |
| CAN-interface | | | Opto | X9 | |
| RS232-interface | | | 9600 Baud | X10 | |
| | | | | | |

3 Basis - Information

| | |
|-----------------------------|---------------------------------------------------------|
| Ambient conditions | |
| Enclosure protection | IP20, VGB4 |
| Norms | EN60204, |
| Ambient temperature | 0 bis +45°C |
| Maximum ambient temperature | +45°C to +60°C with power derating 2%/°C |
| Storage temperature | -30°C to +80°C |
| Humidity in operation | Klasse F rel. humidity <85% , no condensation ! |
| Site altitude | 1000m a.m.s.l. 100%, >1000m with power derating 2%/100m |
| Ventilation | Built-in fan |
| Mounting position | Vertical, Horizontal with power derating 20% |

| Program | Type | Software-Version | Extension |
|----------|---------------|------------------|-----------|
| DS-4xx-x | RESO-12bit | DRIVE_DS 32 | x |
| DS-4xx-x | RESO-12/16bit | | x |
| DS-4xx-x | Encoder | DRIVE_DS 32 | x |
| DS-4xx-x | Sinusgeber | | x |



Important notes:

Mounting surface blank metal, not varnished (surface EMC contact)

Check device for mechanical damage. Mount only perfect devices.

Cut all power prior to assembly.

Insert shortening plug and attach warning signs at installations already electrically connected.

Assembly permitted only by competent professionals.

Vertical mounting position.

Note power reduction if mounted horizontally.

Ensure adäquatem ventilation clearance. (at least 100mm).

Use dimension diagram or drill template to trace fastening holes of device.

Do not mark off from device.

Drill mounting holes (M5) in mounting base.

Screw in screws up to 4mm.

Insert device and tighten screws.

Mount filter and choke near to device.

Surface-contact line shields to mounting surface.

Keep unshielded cable ends as short as possible.

Brake resistors can become very hot. (200°C).

Mount resistors so that neither injuries (burns) nor damage caused by their heat can occur.

Use vibration-proof bolted joints.

Ensure adequate control cabinet ventilation. Use air conditioners for excessive room temperatures (>30°C).

Caution: Operation with devices covered in dew is not permissible!

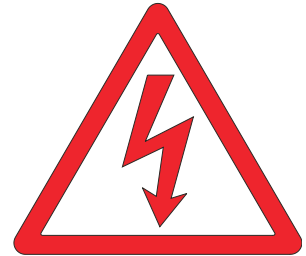

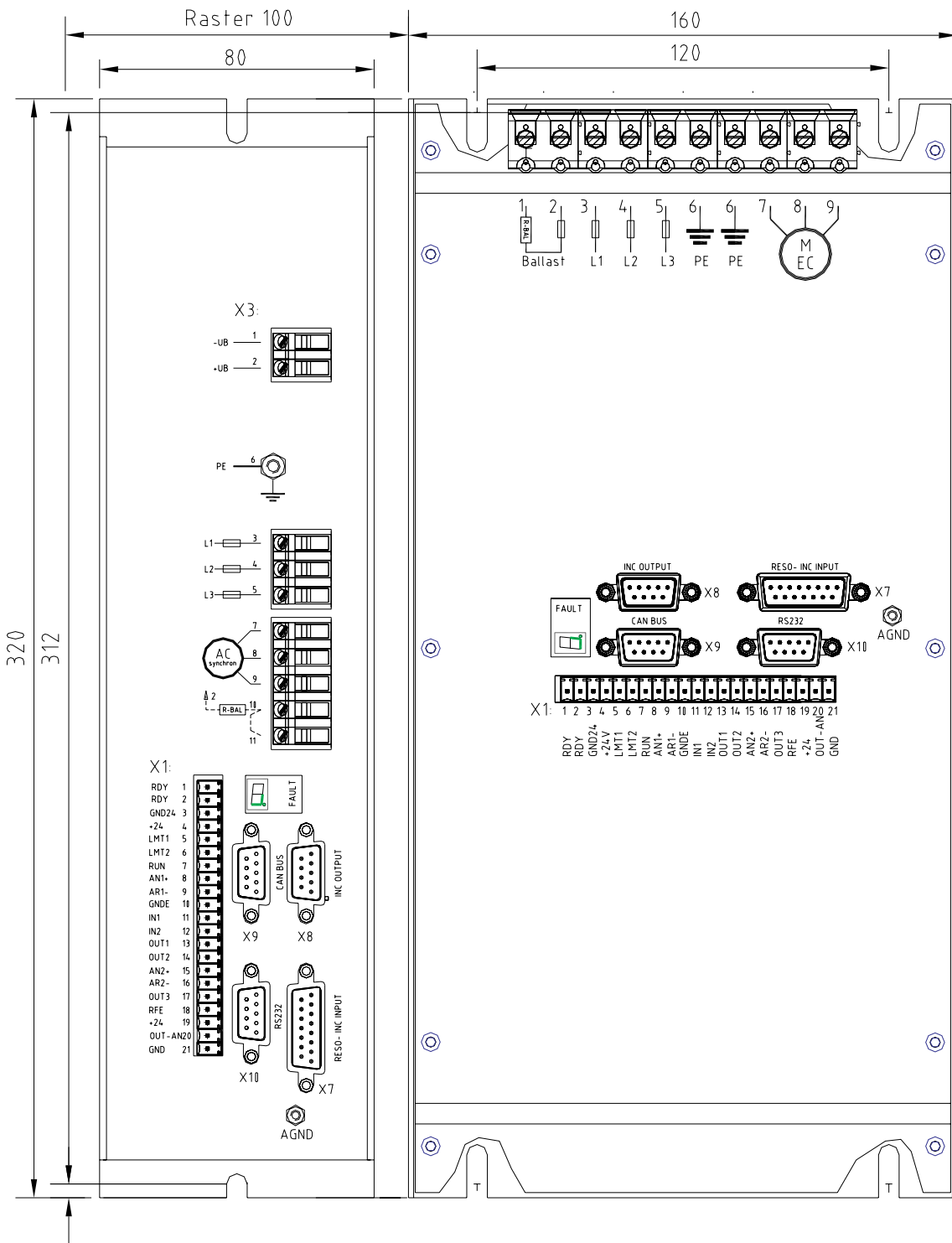

Size 2
DS-405 to DS-420A

Size 3
DS-450

Depth

without connectors
with connectors max.

185mm
250mm

Screw for hex key

M5x10 DIN 912

Dimensions



Dimensions accessories

EMC-Filter

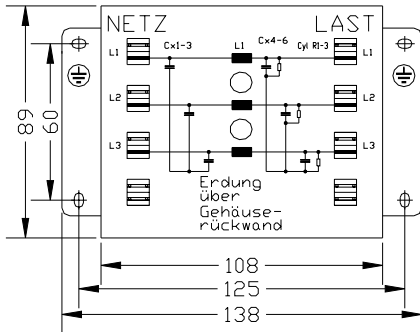

| Type | Voltage | Current | Dimension | W. |
|---------------|---------|---------|------------|-----|
| | V~ | A~ | HxBxTmm | kg |
| F250V-B90-16 | 1x250 | 1x16 | 45x90x40 | 0,4 |
| F400V-B108-16 | 3x480 | 3x16 | 90x140x55 | 0,8 |
| F400V-B150-25 | 3x480 | 4x25 | 130x180x80 | 2,4 |

Filter for stricter EMC - requirements.
 DC-BUS filters and input capacitors are incorporated in the device.
 Mount filter close to device.

Motor choke

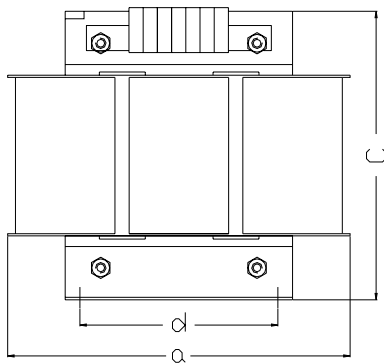

| Type | Current | Indukt. | Dimension | W. |
|-------------|---------|---------|-------------|-----|
| | A | mH | HxBxTmm | kg |
| MDD 1.6a-5 | 5 | 1.9 | 95x54x108 | 1.3 |
| MDD 1.6b-10 | 10 | 1 | 95x58x108 | 1.4 |
| MDD 2b-20 | 20 | 0.8 | 128x80x140 | 2.6 |
| MDD 3c-50 | 50 | 0.5 | 190x115x180 | 11 |

Motor choke cable core to screen capacitance >5nF.
 Cable length 25m approx.

Regen resistor 300W

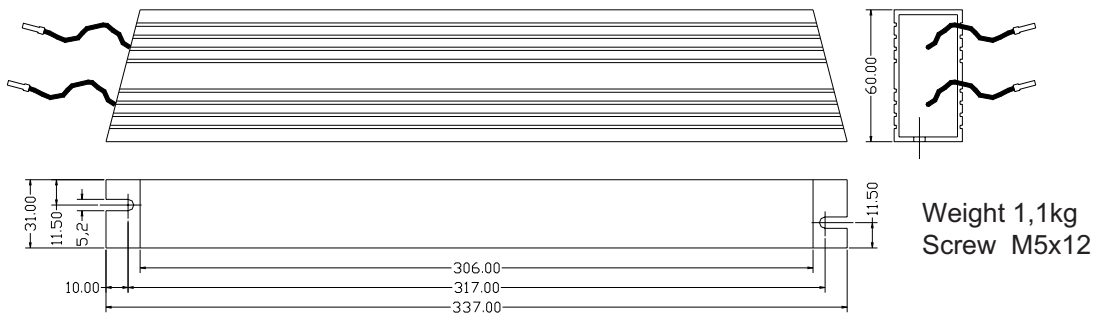

Regenerative discharge resistor in IP65 protection standard aluminium housing

Caution: The regenerative resistor can get as hot as 200°C. Protect the resistor against accidental touch when installing it. Do not place any heat-sensitive components directly at the resistor or in the hot airflow.



important notes

With reference to allocation of connections to the plug and terminal numbers the connection notes are binding.!

All other notes on this subject are not binding.
The input and output lines can be changed and supplemented to comply with electrical regulations and guidelines.

The regulations to be observed are:
Connection and operation notes, local regulations,
EU regulations such as the 2006/42/EG machine directive,
VDE, TÜV and trade association regulations

Cut all power prior to the electrical installation.

Make sure enabling is safe.
Insert shortening plugs,
attach warning signs
Installation is permissible only by electro technically competent professionals.

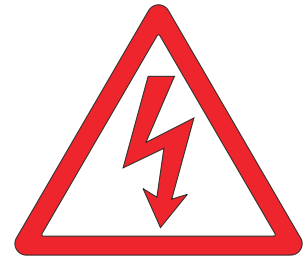

Compare connected loads with information on rating plate.

Ensure adequate fuse protection for the feed, the auxiliary voltage and the external regenerative resistors.

Lay power cables and control lines spacially separated. Perform shield connections and earthing work in compliance with EMC guidelines. Use the right lead cross sections.

Caution: Operation without a " PE - connection " is forbidden!



Rating plate (example),

| | |
|----------------------------------------------------------------------|-----------------------------------------------|
| UniTek | Industrie Elektronik G m b H |
| 726 Drehstrom-Servoverstärker DS 412-.2RS | CE |
| Leistungsanschluss 3(1) x 30V~ bis 480V~ Nennstrom 12A eff IP20 | |
| Hilfsspannung 24V= Tel +49 (0)7195/9283-0 Fax+49(0)7195/928329 | Info@unitek-online.de www.unitek-online.de |

serial number

055555

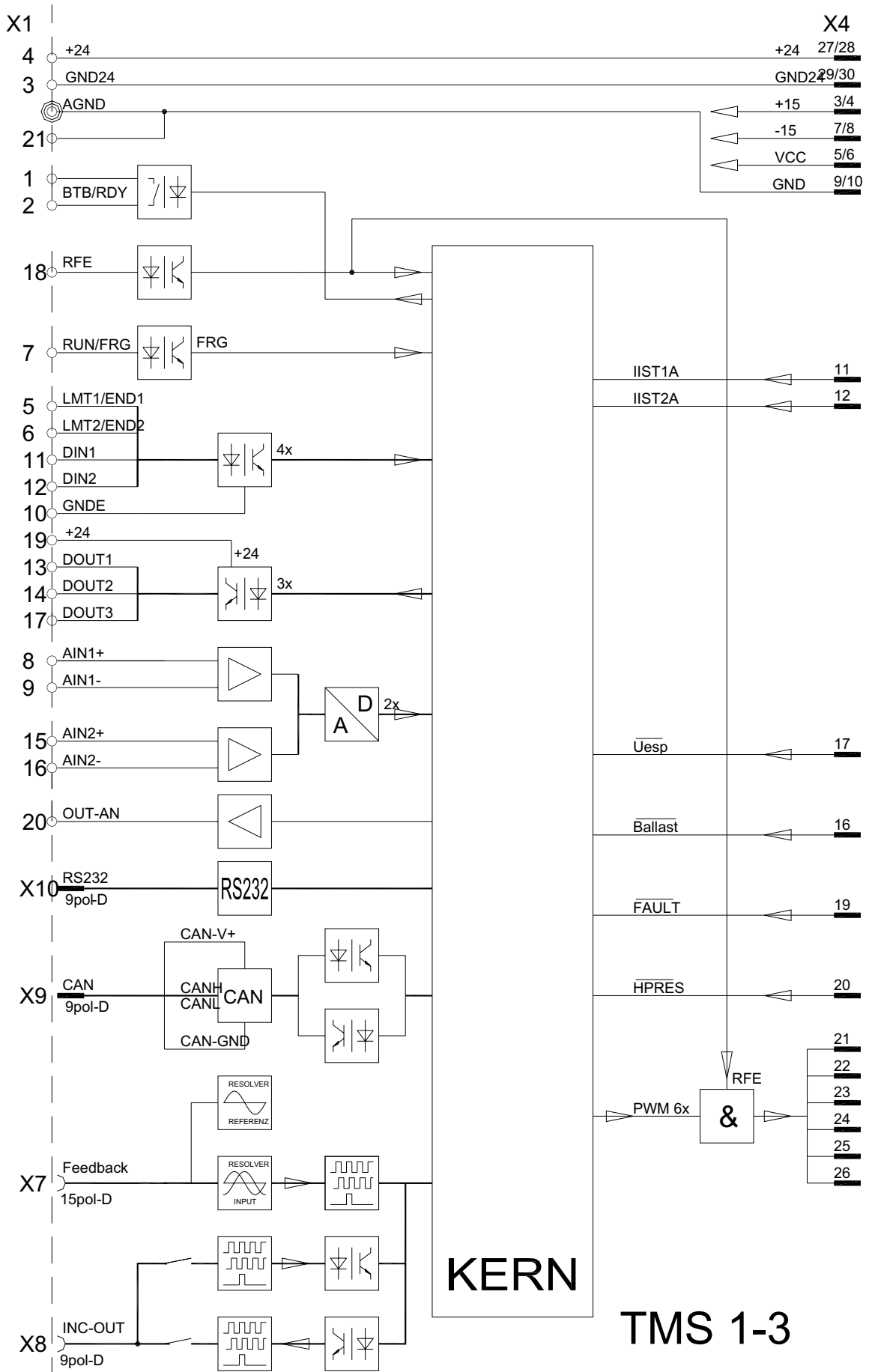

5 Electrical Installation

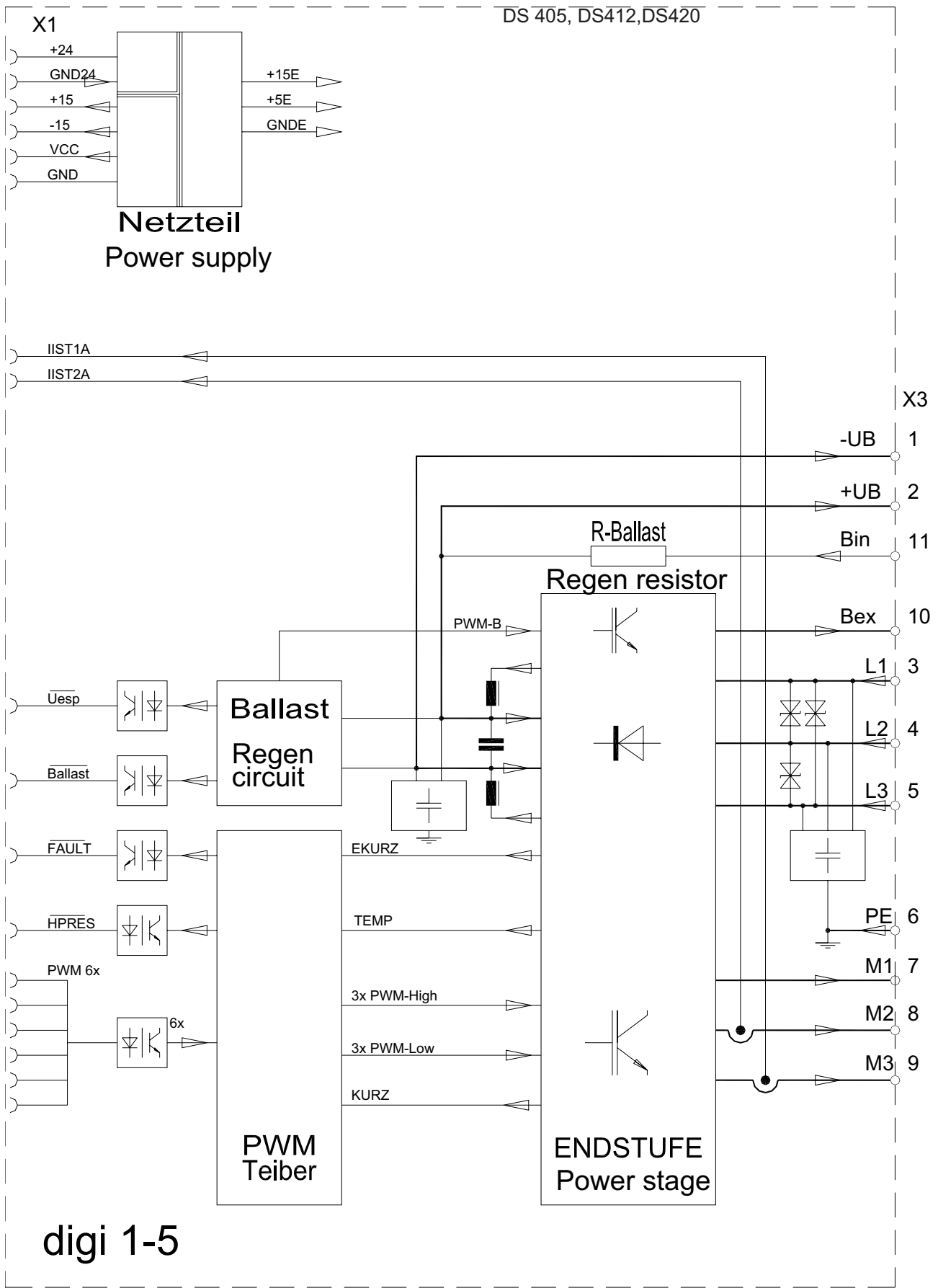

Connection diagram DS405.2, DS412.2, DS420.2

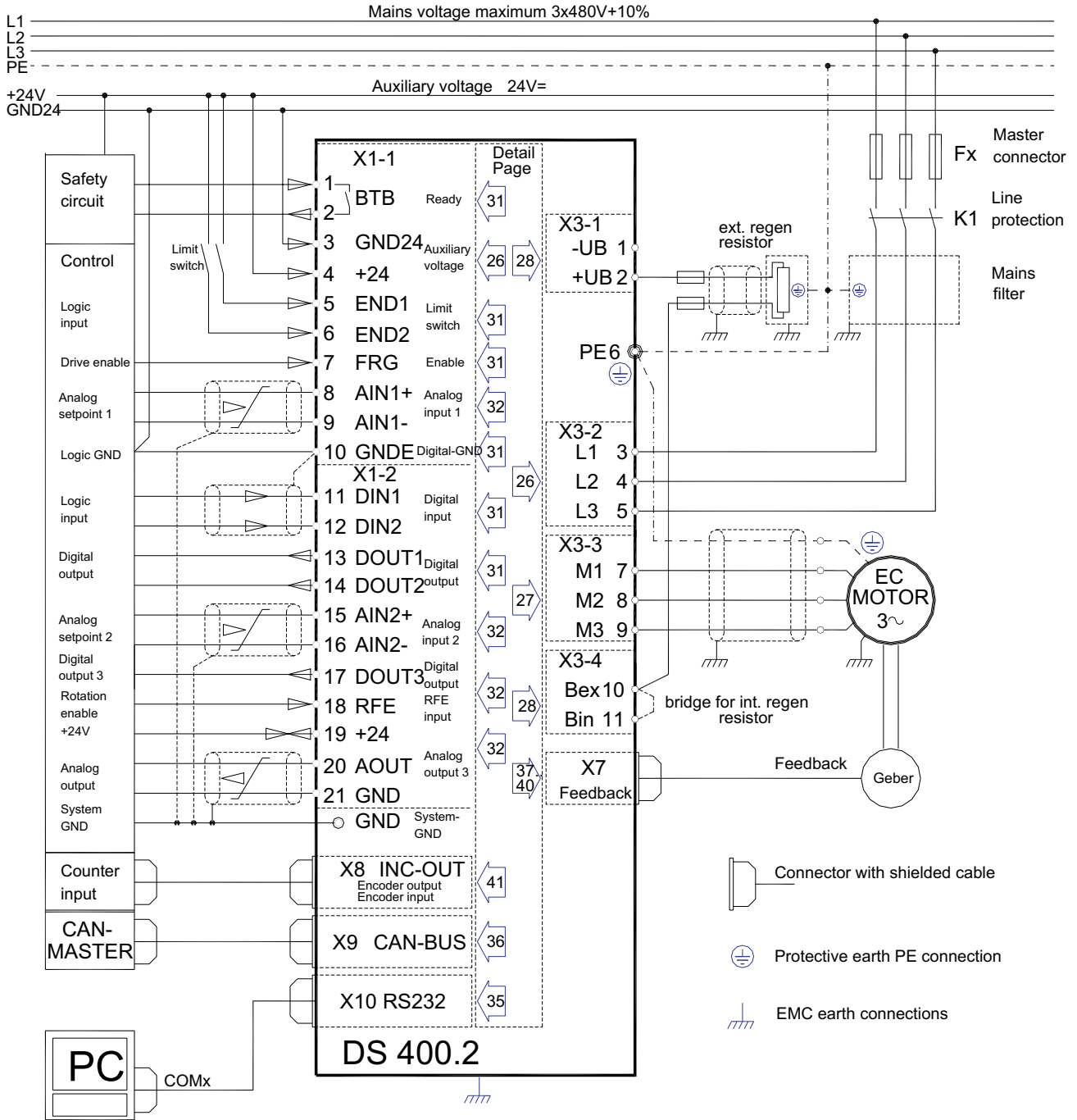

5 Electrical Installation

Connection diagram DS450.2

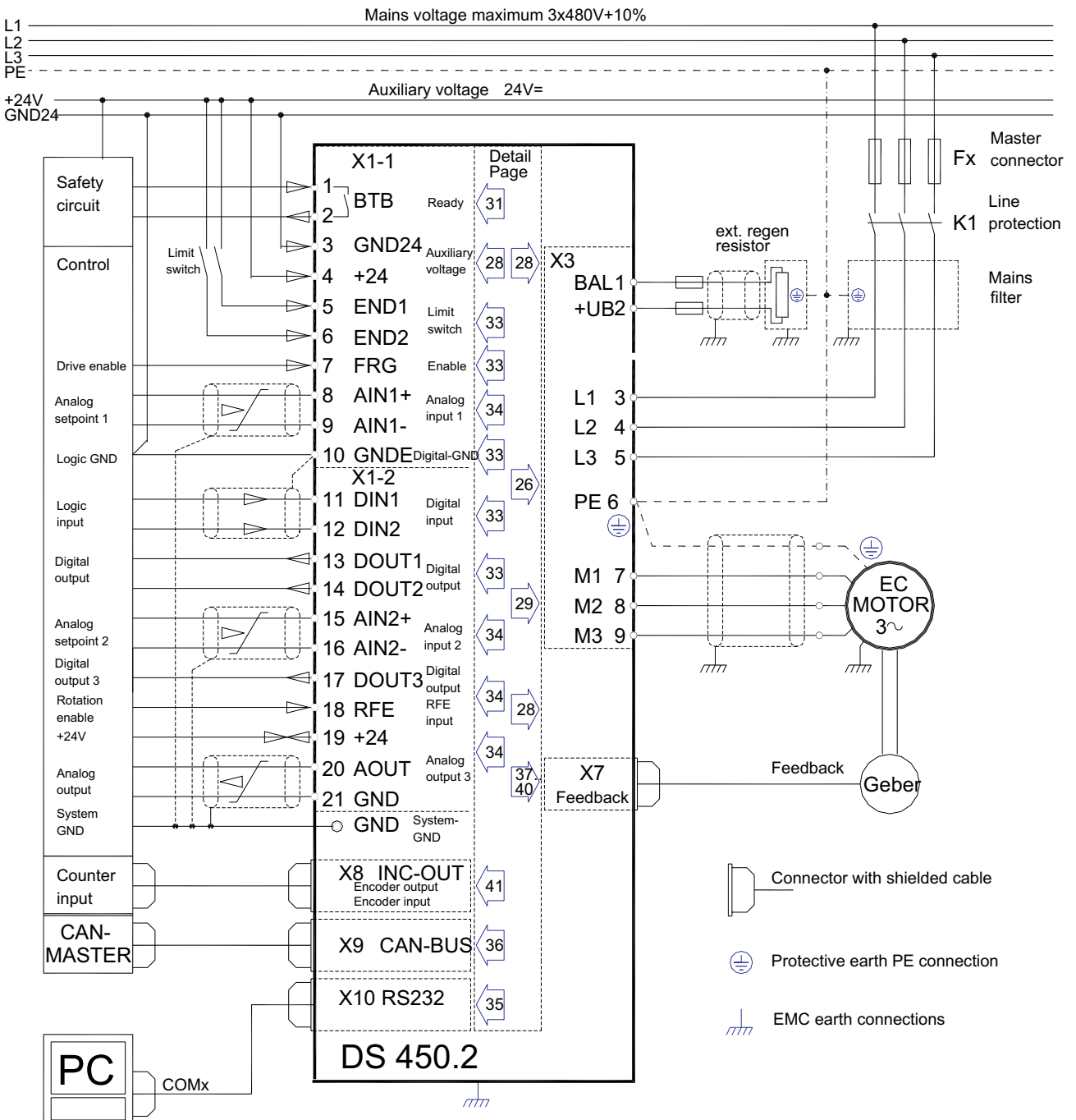

Connection diagram

Connection diagram DS405.2, DS412.2, DS420.2
für DC-BUS mit einspeise-Rückspeise-Modul

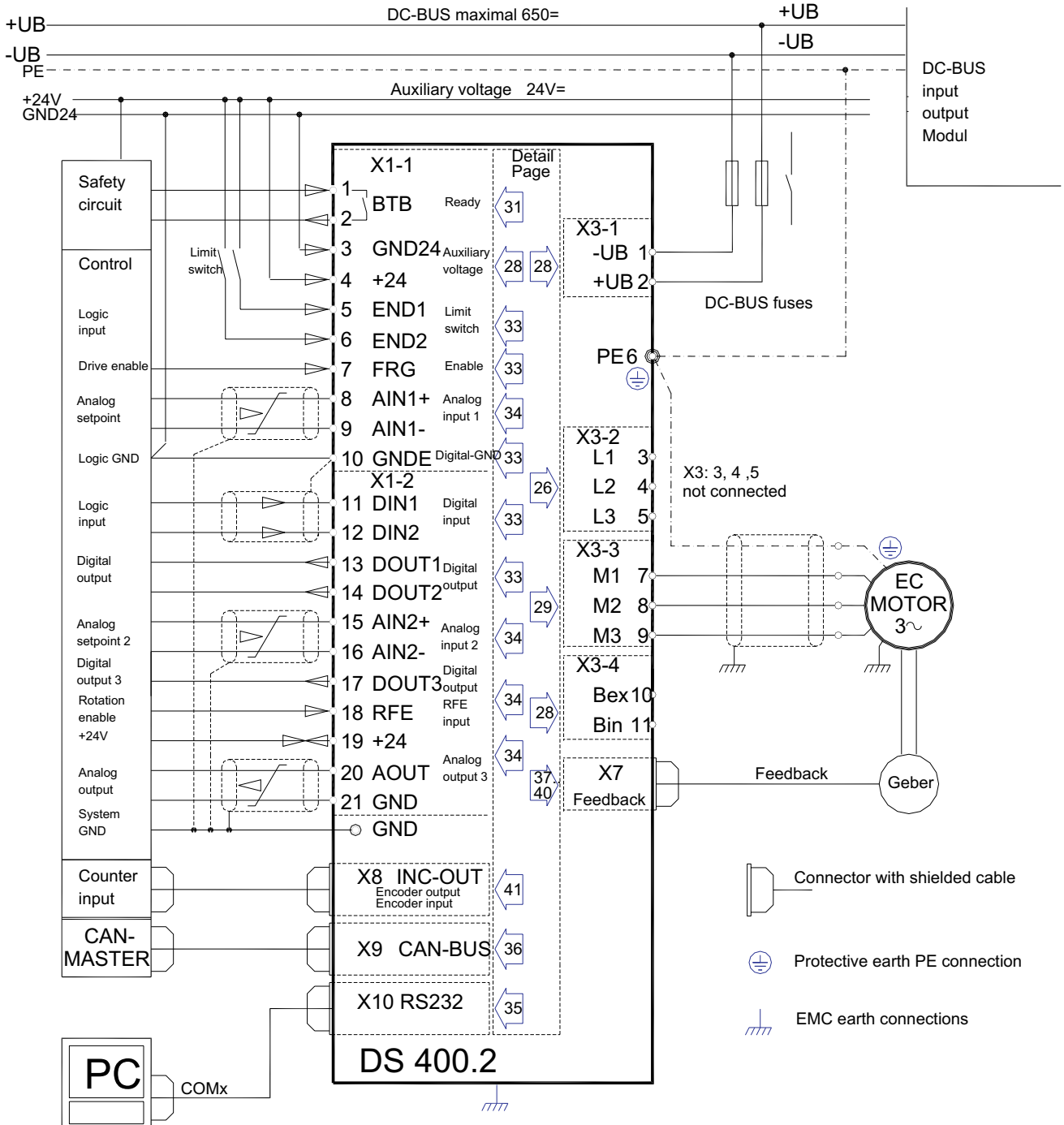

5 Electrical Installation

Connection diagram DS 450.2 für DC-BUS mit Einspeise-Rückspeise-Modul

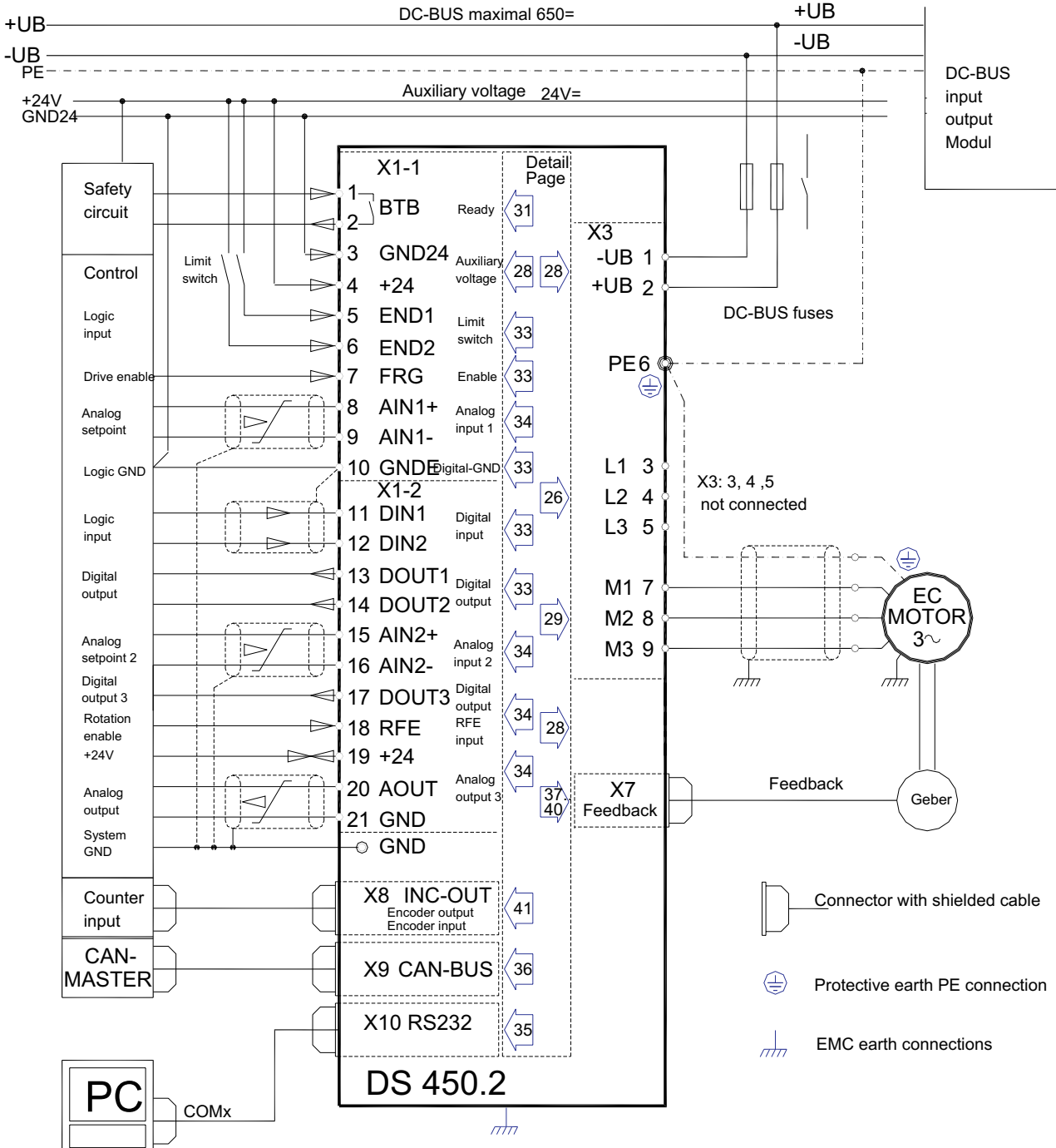

5 Electrical Installation

Connector overview DS450.2

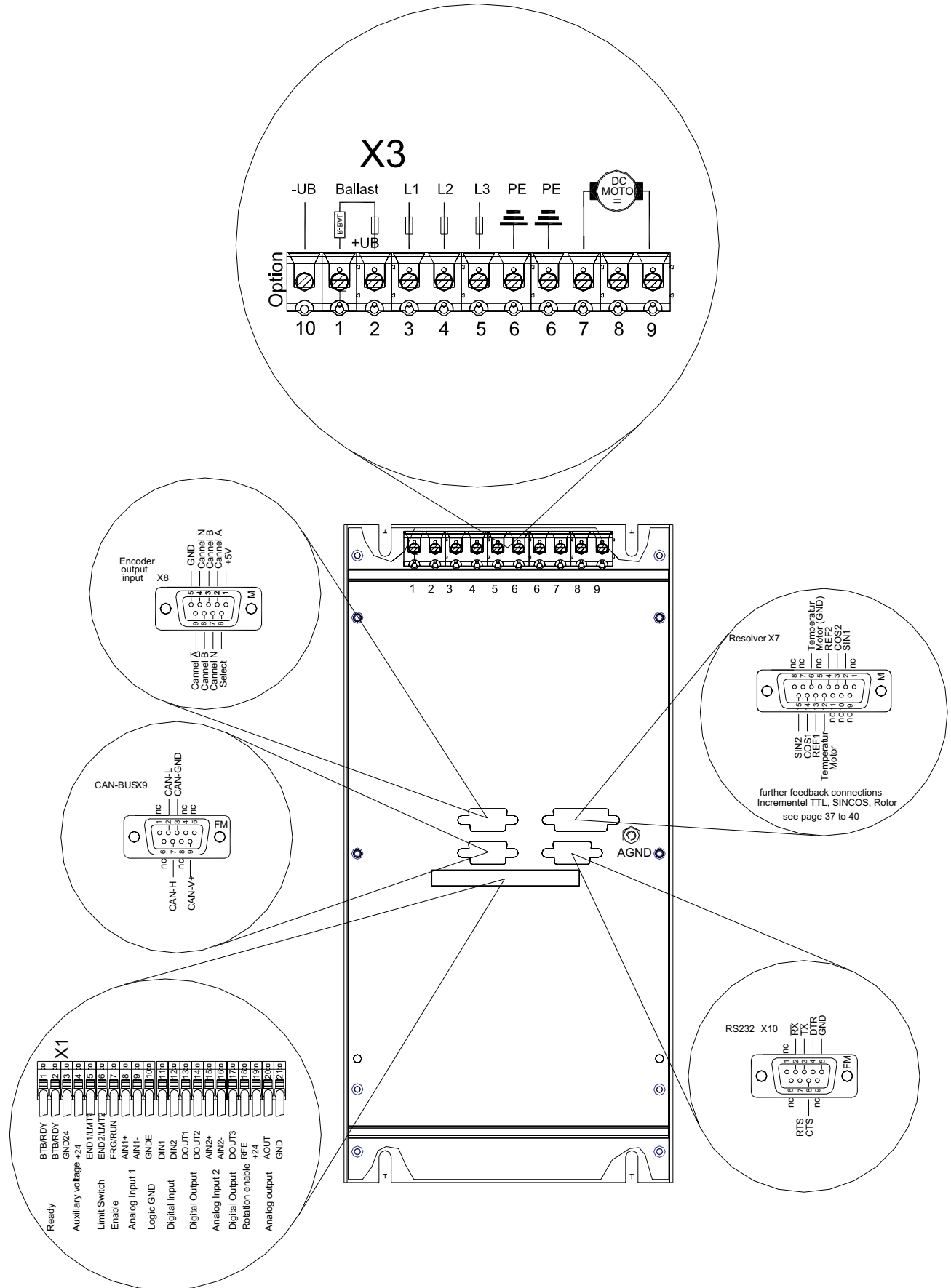

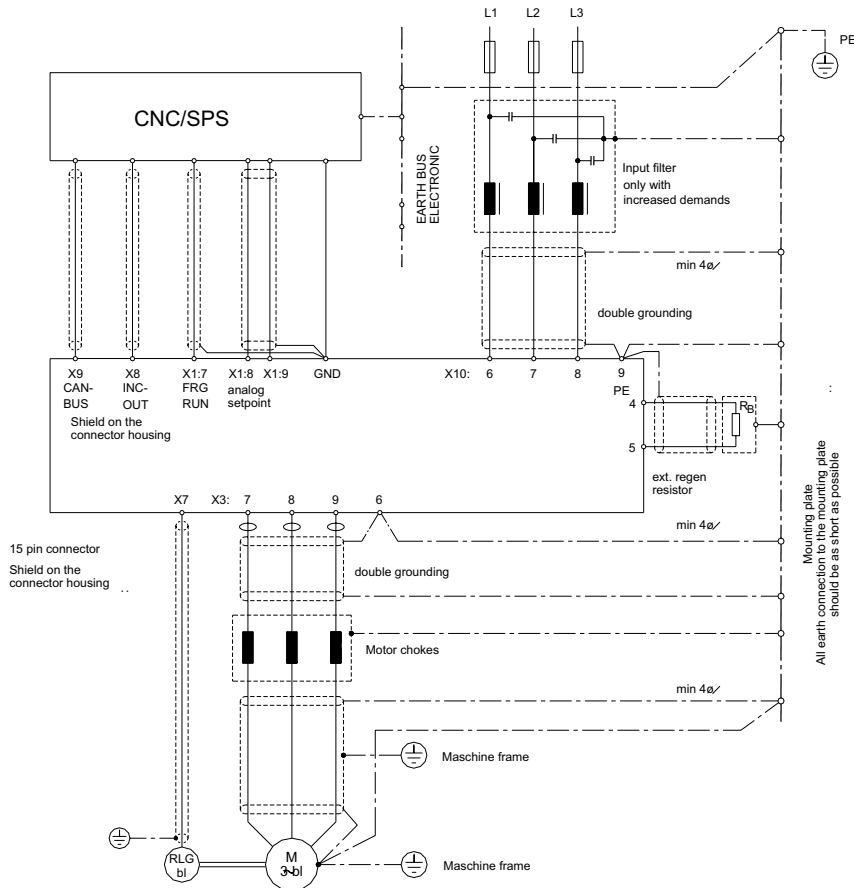

Under the following installation and test conditions the devices comply with the EU 2004/108/EG guideline in standards EN61800-3

Assembly:

The controller is conductively mounted on a 500x500x2 mm blank metal assembly base. For 10 mm the assembly base is connected with the PE. For 10 mm the motor housing is connected with the PE. Zero of device For 2,5mm X-AGND is connected with the assembly base. Device's -PE - screw X3:6 connected to assembly base with a 4mm line

Control connections:

Signal lines shielded, analog signal lines twisted and shielded

Mains three-phase connection:

3x 400V~ with protective earthed conductor

Motor connection:

Motor connection shielded, surface earth contact

When mounted in machines and installations it is forbidden to start the proper use of the device until the machine or the installation has been approved to comply with the regulations of the 2006/42/EG machine directive and the 2004/108/EG guideline.

For cars ECE-R83, ECE-R100
A manufacturer's certificate is available.



5 Electrical Installation

frei



Connection to the grounded AC-or three-phase system (TN-C-Mains).

Unbalanced grounded and do not connect grounded systems only isolation transformer!
 Connection on the T-NC network

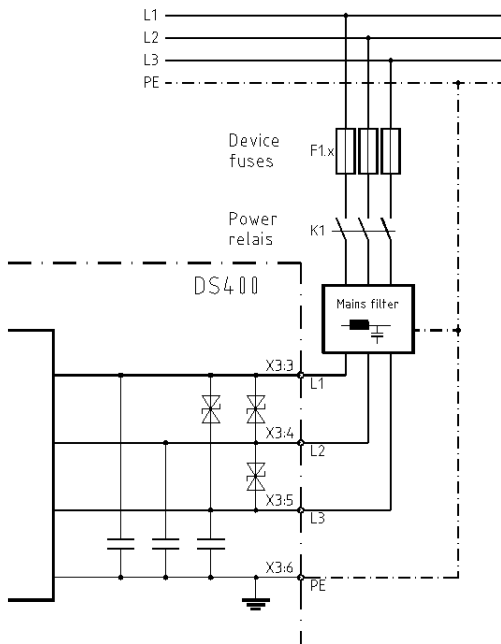

Do not, even briefly, exceed maximum connected voltage of 528V~.

Destruction hazard!!



F1 = FF safety fuses or semiconductor cutouts

Additional power filter in increased EMC conditions.
 DC link filter and input capacitors are installed.
 Leakage current > 60mA



Connection on the T-NC network with autotransformer.

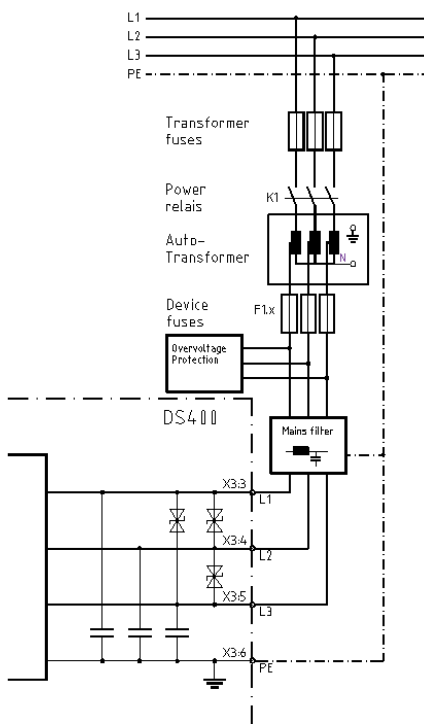

Do not, even briefly, exceed maximum connected voltage of 528V~.

Destruction hazard!!

Transformer fuse slow

F1 = FF safety fuses or semiconductor cutouts

Additional surge protection to transformer switching
 Overvoltages

Additional power filter in increased EMC conditions.
 DC link filter and input capacitors are installed.
 Leakage current > 60mA

When supply voltage <30V the output stage is electronically locked. (no BTB signal)

5 Electrical Installation

Attention: In case of supply networks without PE conductor.

Connection only via isolation transformer

Connection on the TT network

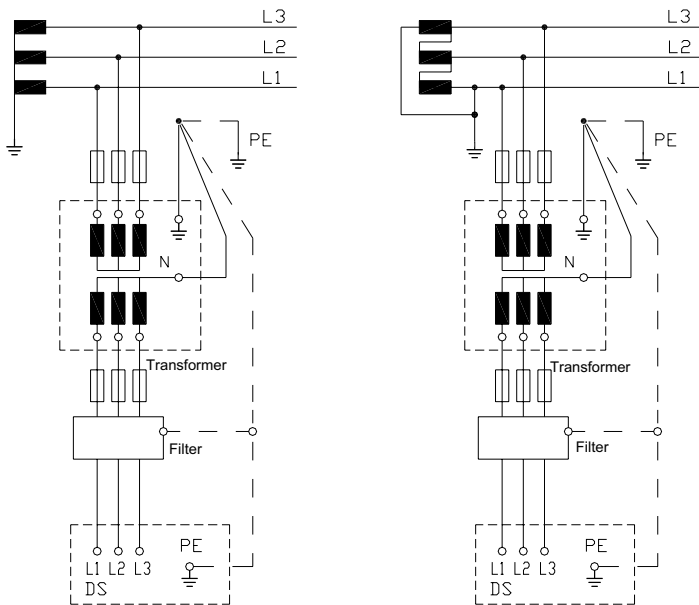

TT network

Asymmetric three-or four-wire three-phase system with a direct ground.

PE device on earth

Connection on the IT network

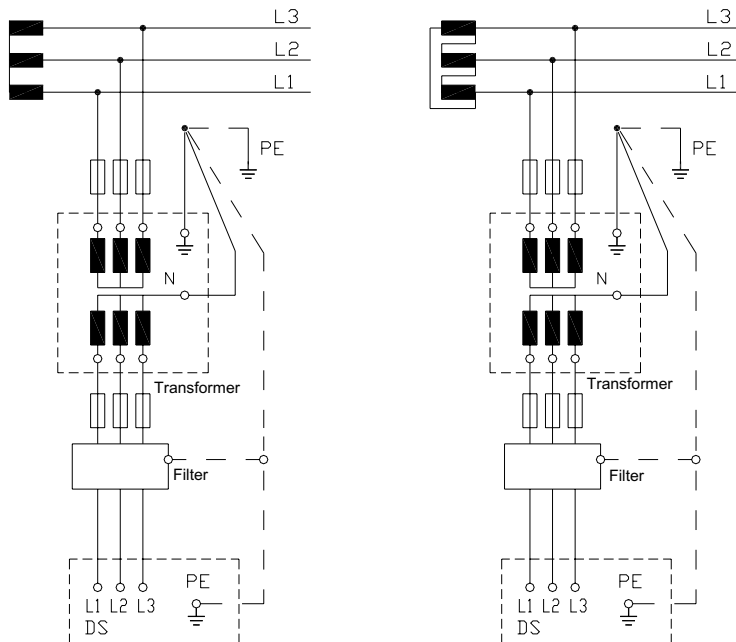

IT network

Asymmetric three-or four-wire three-phase system with no direct grounding.

PE device on earth

Connection

| Type | Mains supply 1phase+N 1x30V -10% to 1x480V +10% 50/60Hz | Mains supply 3phase 3x30V -10% to 3x480V +10% 50/60Hz | Cable- Dimensiont mm ² AWG | | Fuses AFF | Power relais Dime | Mains filter Type |
|------|---------------------------------------------------------------|-------------------------------------------------------------|---------------------------------------------|----|--------------|-------------------------|----------------------|
| 405 | L1=X3:3, N=X3:4 | L1=X3:3,L2=X3:4,L3=X3:5 | 1 | 18 | 10 AFF | DL00 | F250V-B90-16 |
| 412 | L1=X3:3, N=X3:4 | L1=X3:3,L2=X3:4,L3=X3:5 | 1.5 | 16 | 20 AFF | DL0 | F400V-B108-16 |
| 420 | nicht möglich | L1=X3:3,L2=X3:4,L3=X3:5 | 2.5 | 14 | 40 AFF | DL0 | F400V-B150-25 |
| 450 | nicht möglich | L1=X3:3,L2=X3:4,L3=X3:5 | 6 | 10 | 63 AF | DL2 | a.A. |

PE connection point: Earth-Bolt X3:6 **Warning! Use without PE is forbidden!**

Inrush

The initial inrush current is internally limited by an NTC resistor 10 times the rated current (about 2ms). The response is maintained between off and on again when a waiting time of 120sek is maintained. The NTC resistance is in the cooling power of the equipment fan. For faster turn-off, the inrush current to increase to 30 times the value (1ms). The switching contacts of the power contactors must be designed for these values.

Precharge

By using the assembly precharge the charge current to 2 times rated current is limited. The contactor K1 is switched time-delay.

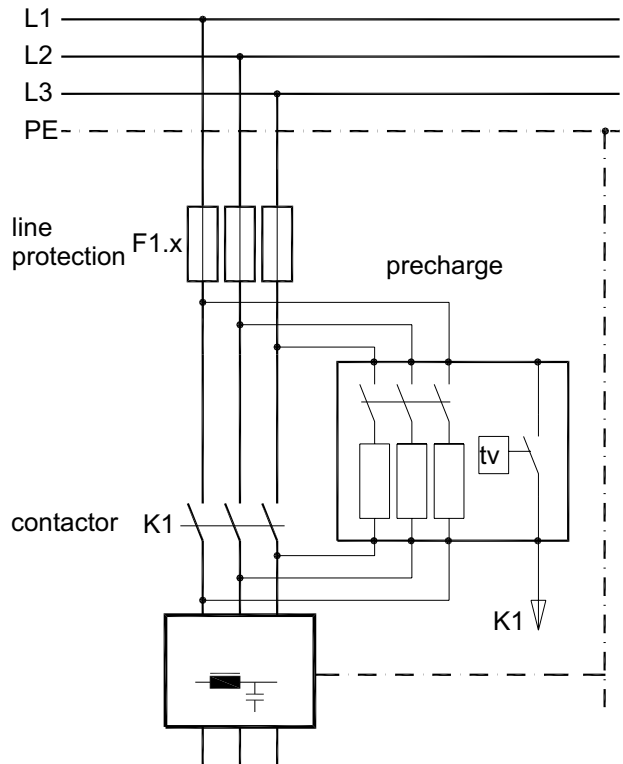

Auxiliary voltage connection

Mains potential-free 24V= +/- 10% / 2A auxiliary direct current.

The auxiliary voltage has a: galvanic connection to the logic voltage, galvanic safety dc decoupling to all internal supply voltages of the device, an internal self-healing fuse, an EMC filter, an external fuse only for line protection.

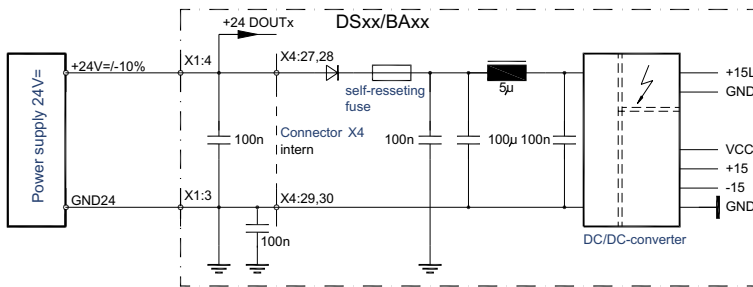

| | |
|---------------------------------|------|
| Input voltage 24V DC | X1:4 |
| GND24 | X1:3 |
| Ripple | 10% |
| Power up current | 2A |
| Nominal current | 0.8A |
| GND connection must be earthed! | |

Note: In addition to the internal supply current (0.8A) the sum of the output currents (DOUT) must be provided by the mains module 24V.

Note: If the auxiliary voltage is inferior to 20V - even in case of short-time voltage drop-outs - the internal mains module is switched off. Any data of the RAM are deleted!

The speed and the position command values are set to zero and any calibrated data are deleted.

The LED signal for the state "OK" is dark.



5 Electrical Installation

Motor power connection

Use only Unitek approved, electronically commutated synchronous motors (brushless DC motors, EC motors) with a resolver or an incremental encoder.
See Appendix A (specific motor connection and parametrizing rules).

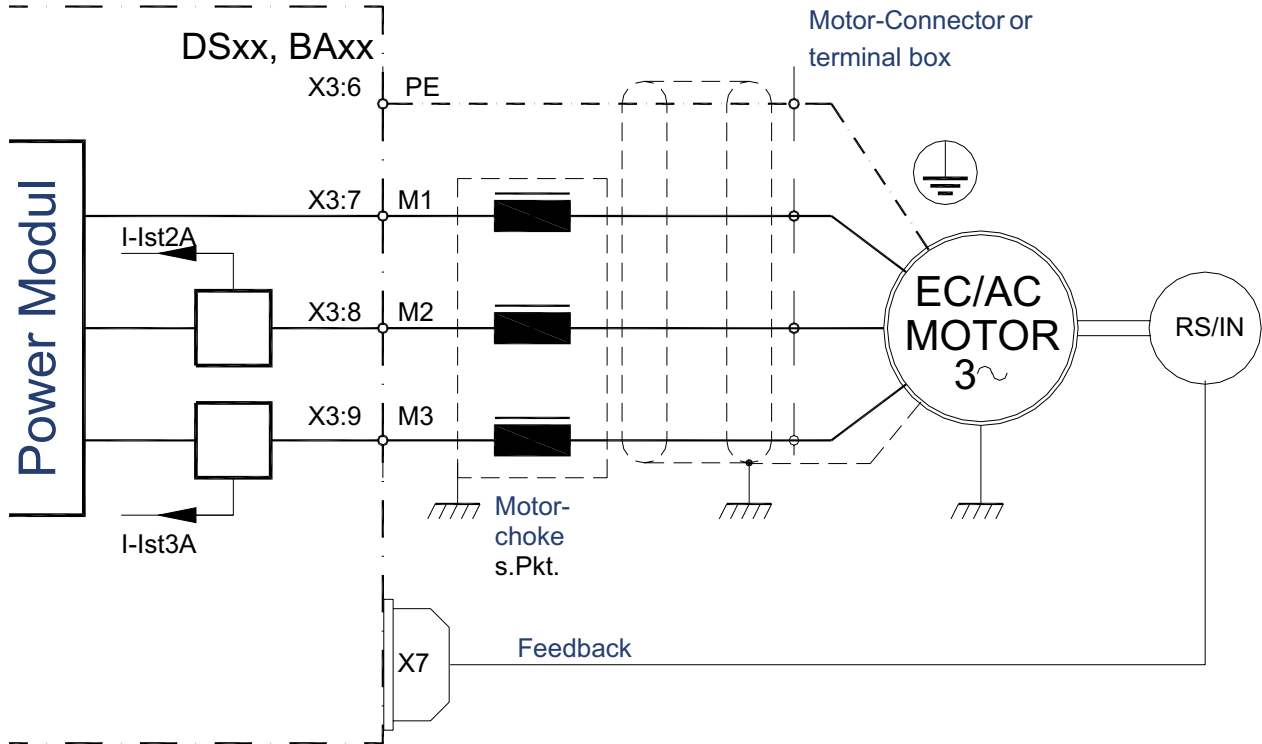

| | | | | |
|-------------------------------|------|------|------|------|
| Cable indication | PE | M1 | M2 | M3 |
| Connector | X3:6 | X3:7 | X3:8 | X3:9 |
| Correct wiring is essential ! | | | | |

Motor cables, 3 wires + simply shielded protective earth conductor for 600V~, 1000V=, shield capacity 150pF/m. See table for minimum cross-section

| | | | | |
|----------------------------|-----|-----|-----|-----|
| Type DS | 405 | 412 | 420 | 450 |
| Cable dim. mm ² | 1.5 | 2.5 | 4 | 10 |
| Cable dim. AWG | 16 | 14 | 10 | 6 |

Motor choke.
Only required upwards of a shield capacity of >5nF. approx. 25m motor cable.

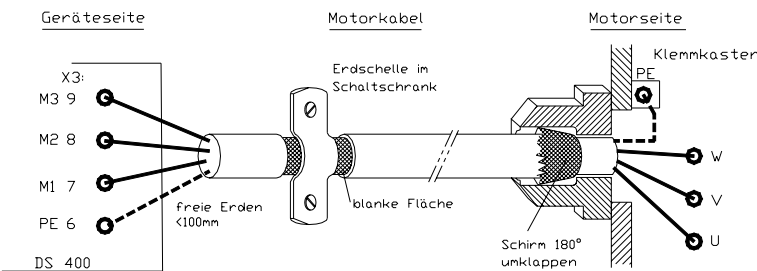

Shielded connection:
Surface connection at entry to control cabinet. Surface or as short as possible connection at the motor end.

Use multiple earthing for long motor leads. (e.g. an earth clamp on the machine body every 5 m). Connection sequence, cable cross section, shield connection.

Regenerative circuit DS 405, DS412, DS420

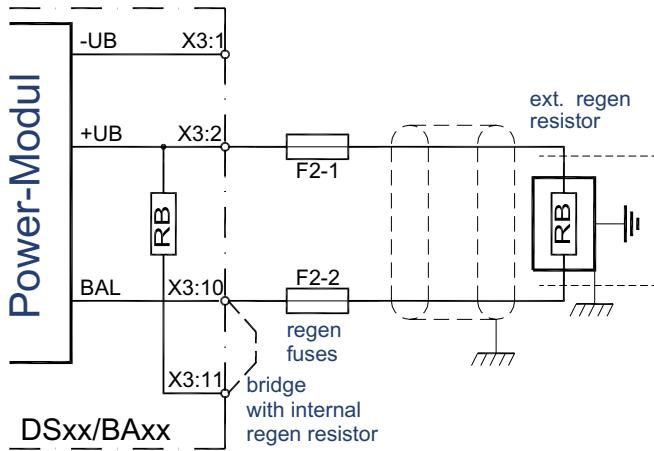

The energy generated during braking is refed to the DC-BUS. The Elkos DC-Buses are able to store only a small amount of energy. The excess energy has to be converted into heat in the regenerative resistor. The internal resistor is designed for drives without flyweights. Always use external regenerative resistors for flyweights or design uncertainties. (See page 14).

Regenerative circuit DS450

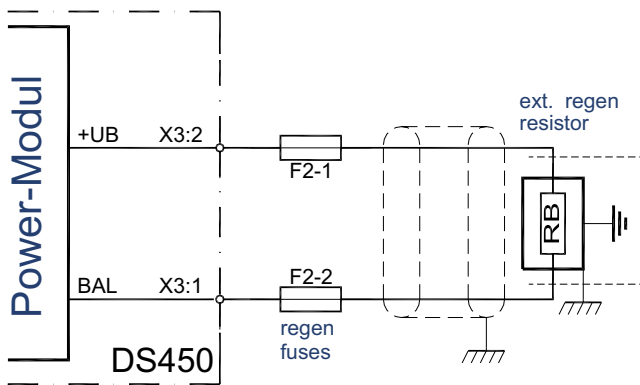

F2- protection from earth fault. Electronic limit from overload and regenerative discharge short circuit.

| Type DS | | 405 | 412 | 420 | 450 |
|-------------------------|----------|-----|-----|-----|------------------------------|
| Internal regen resistor | Ohm | 80 | 51 | 42 | Only external regen resistor |
| Continius power | W | 50 | | 100 | |
| Pulse power 1s | kW | 1 | | 2.5 | |
| External resistor | min. Ohm | 80 | 51 | 40 | 16 |
| Fuse F2 | AF | 10 | 16 | 25 | 80 |

Caution: Note flyweight (rotor moment of inertia) for DS420 motors. The internal regenerative resistor has a wattage of only 100.

5 Electrical Installation

External regen resistor

Dimensionierung

Maximum breaking power calculation

$$P_{\max} \text{ [W]} = \frac{J_g \times n \times n}{91 \times t_B}$$

- J_g = Total inertia at motor [kgm²]
- n = maximum speed [min⁻¹]
- n = difference in speed [min⁻¹]
- t_B = braking time [s]

Power regen resistor

$$P \text{ regen resistor [W]} = \frac{P_{\max}}{K1 \times K2}$$

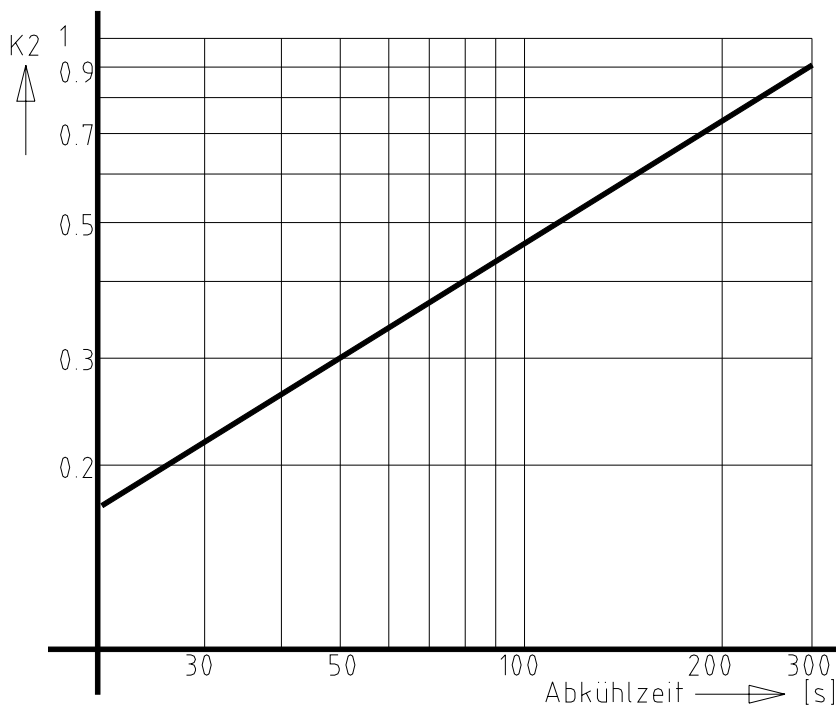

Digital input

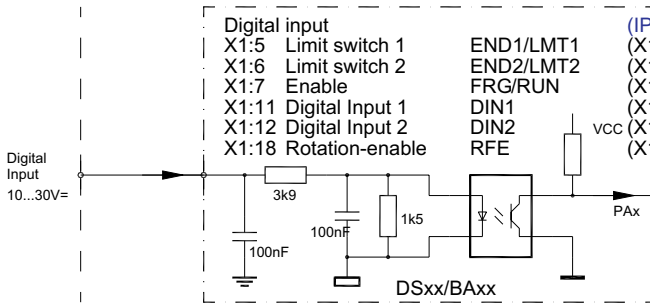

Opto-input
 Input voltage
 H-level (ON) +10 bis +30V
 L-level (Off) 0 bis +6V
 input current max. 14 mA
 Ratet voltage/cure +24V/10mA
 Referenc ground GNDE(X1:10)

The enable input (FRG/RUN) and the input for the rotating field enable (RFE) are fixed, they cannot be programmed.
 Without the enable FRG/RUN the servo-drive is electronically disabled (no PWM pulses).
 Without the rotating field enable RFE the rotating field of the output stage is additionally electronically disabled (2 disable channel).
 The drive is free of torque (no holding torque).
 The remaining four digital inputs can be programmed.
 The inputs LMT1 (X1:5) and LMT2 (X1:6) are preferably to be used as inputs of the output stage switch.

| Input | Plug | Function | Status |
|-----------|-------|---------------------------|--------------|
| FRG/RUN | X1.7 | Enable | fix |
| RFE | X1:18 | Rotation Enable | fix |
| END1/LMT1 | X1:5 | Limit switch 1/Dig. Input | programmable |
| END2/LMT2 | X1:6 | Limit switch 2/Dig. Input | |
| DIN1 | X1:11 | Digital Input 1 | |
| DIN2 | X1:12 | Digital Input 2 | |

External Power Supply for Inputs and Outputs

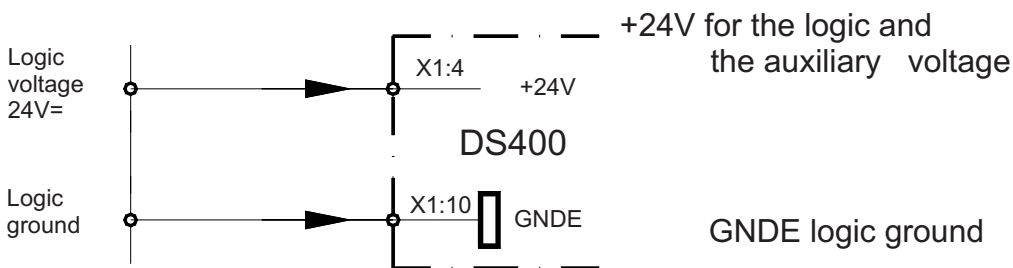

5 Electrical Installation

Safety input RFE (Rotation enable)

Warning!

If the input of the enable or of the rotating field enable are switched off, the drive is free of torque. The drive could move if there is no mechanical brake or block provided.

The motor conductors are not dead. Only the rotating field is disabled. Prior to any work or maintenance on the motor or servo-drive, the servo-drive must be completely disconnected from the mains power supply.



Operation with RFE input

Two-channel disable of the enable via a safety switching device.

Enable input FRG/RUN + rotating field enable input RFE.

Switching-on

Contacts of the safety device closed: enable FRG/RUN 0.5s after RFE.

Safety switch-off

Contacts of the safety device open:

- there is no FRG/RUN signal in the 1 disable channel to disable the PWM pulses in the processor,
- there is no RFE signal in the 2 disable channel to disable the PWM pulses at the output of the processor.

Restart

Release the safety switching device.

Contacts of the safety device closed.

The motor can only move after a second disable FRG/RUN (after the rotating field enable).

Operation without RFE input

The input RFE must be bridged with the logic voltage.

If the logic voltage corresponds to the supply voltage, the RFE input is bridged with +24V.

Enable FRG/RUN at least 0.5s after the RFE signal.

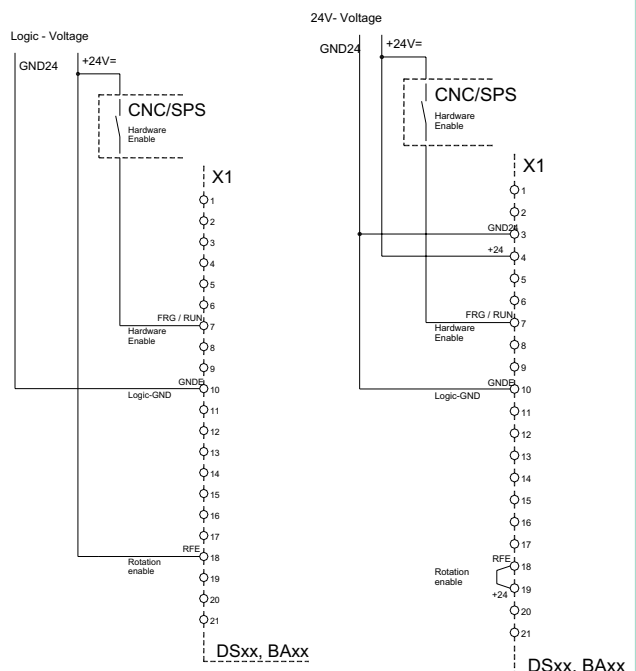
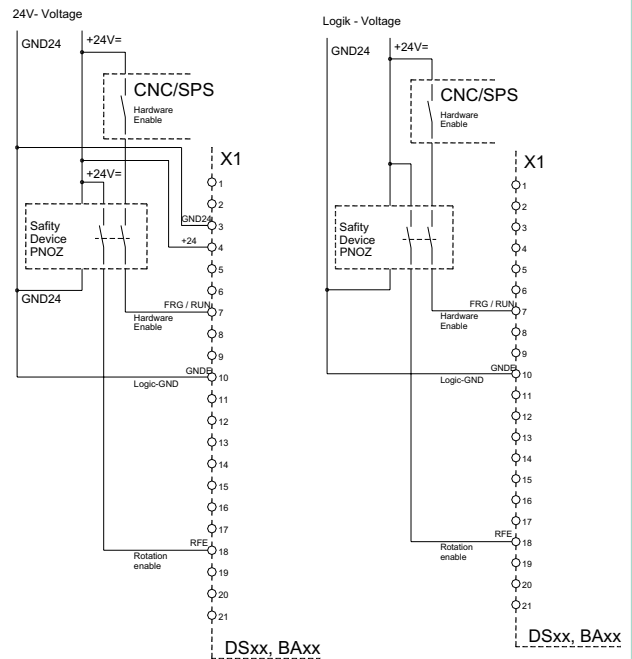

Digital logic outputs (open emitter)

The logic outputs 1 to 3 are rated for 24V and 1A (short-time: 2A)

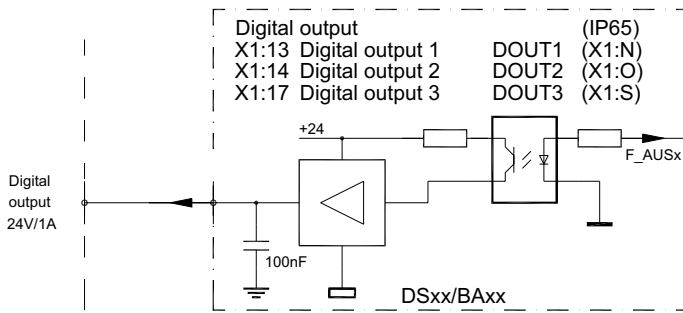

Output voltage
 On-level max. +24V
 Off-level <1V
 Output current nom. 1A
 Output current max. 2A
 Voltage reference +24V (X1:4)
 ground reference GNDE(X1:10)

It is possible to program an energy saving program (clocked output).
 The logic output 4 (24V, 3A) at the power section is only available with certain **devices**.

Signal contact “Ready BTB/RDY” (Solid state relay)

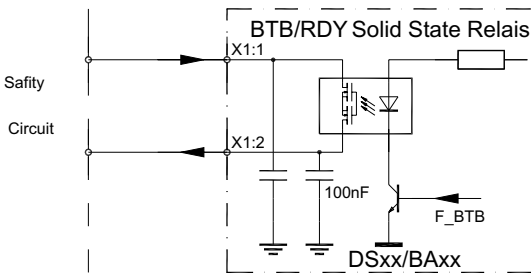

Contact for max. 48V/0.2A
 Capacitive load max. 1myF
 Contact resistance max. 2 Ohm
 The contact is closed when the device is ready for operation.
 State signal via seven-segment LED



BTB opens (red LED, open relay contact)

in case of error messages
 in case of under-voltage of the auxiliary voltage (<20V)

The message “under-voltage in the bus circuit” can be programmed (see Manual NDrive)

| Output | Plug | Function | Status | Parameter |
|---------|------------|------------------|--------------|-----------|
| BTB/RDY | X1:1, X1:2 | Ready | fix /Relay | |
| DOUT1 | X1:13 | Digital output 1 | programmable | |
| DOUT2 | X1:14 | Digital output 2 | programmable | |
| DOUT3 | X1:17 | Digital output 3 | programmable | |
| DOUT4 | X | Digital output 4 | programmable | |

Externe Spannungsversorgung für Ein- und Ausgänge

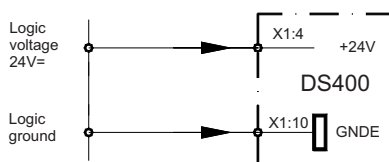

+24V for the logic and the auxiliary voltage
 Observe the sum of all output currents!
 GNDE logic ground

5 Electrical Installation

Analog inputs +/- 10V

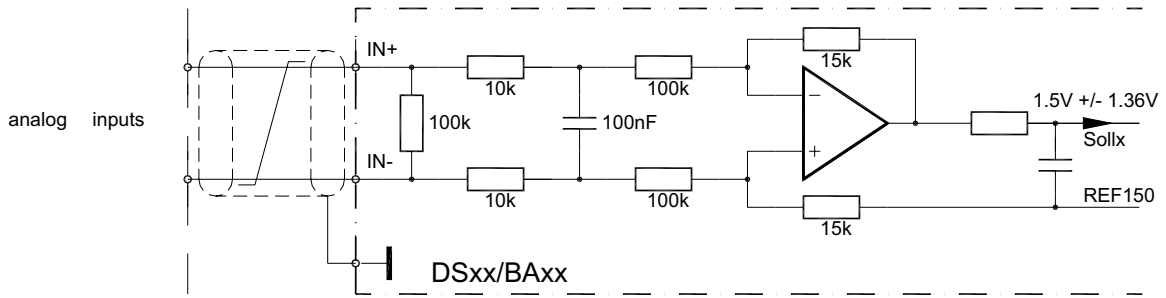

| Input | Plug | Basic- Function | Voltage | Status | Parameter |
|-------------|-------------|---------------------|---------|--------|-----------|
| AIN1+,AIN1- | X1:8, X1:9 | Speed command value | +/-10V | prog. | |
| AIN2+,AIN2- | X1:15,X1:16 | Current limit | +/-10V | prog. | |

Characteristics

| Differential input | AIN1+/AIN1- | AIN2+/AIN2- | |
|--------------------|--------------|-------------|--|
| Input resistance | 70k | | |
| Maximum voltage | +/-12V | | |
| Resolution | 11Bit + sign | | |
| | | | |

The direction of rotation of the motor can either be changed by swapping the \pm connections at the differential input, or by means of a logic input or by programming. The analog inputs can be assigned to different functions.

With a digital command value (RS232, x-bus)

- the analog input AIN1 can be programmed as external analog speed limit
- and the analog input AIN2 can be programmed as external analog current limit.

Analog Output +/- 10V

| Output | Connection | Basic function | Voltage | State | Param. |
|--------|------------|--------------------|---------|--------------|--------|
| AOUT1 | X2:20 | Speed actual value | 10V | programmable | |
| GND | X2:21 | Signal zero | 0V | fixed | |

RS 232:

Via the serial PC RS232 interface the DS400 amplifier is programmed and operated for the start-up.
The software is described in the DS software manual.

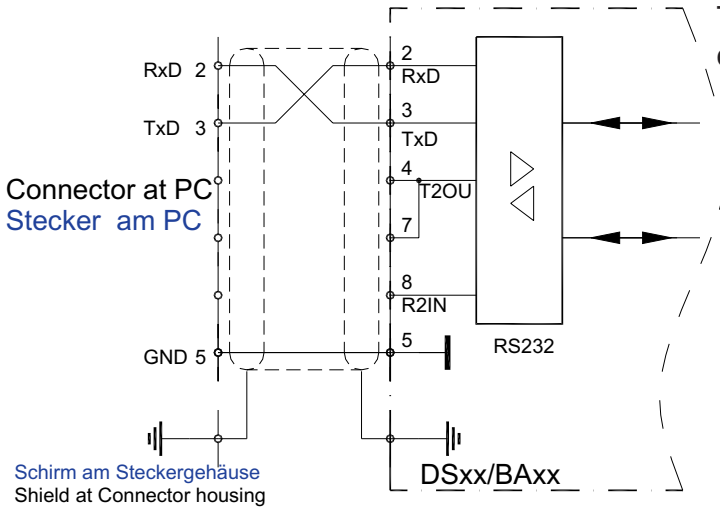

The serial interface is galvanically coupled with the device - zero (GND) .

The DS-xxx (D connector X10) and the serial interface (COMx) of the pc must only be connected using a null modem cable.
Do not use a null modem link cable!
Install the cable only after disconnecting the device from the mains.
The interface is hard-coded to **115200Baud**.

Null modem cable
Pin assignment. Solder side.
Contact shield with the plug housing.
Cable length max. 10m

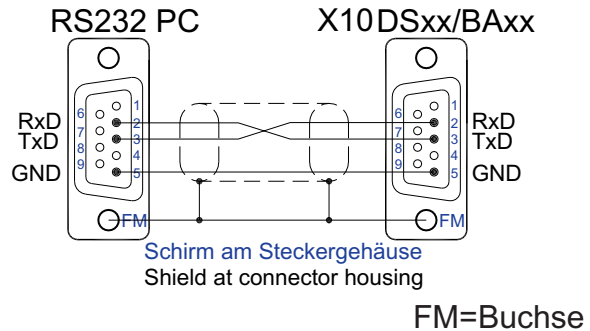

In case of strong interferences at the interface a line filter should be installed.
Notebooks with a USB-RS232 converter are usually susceptible to interference.

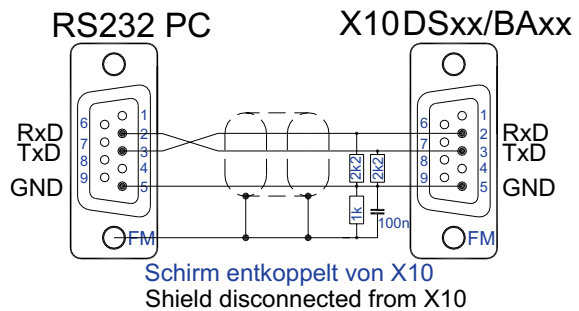

5 Electrical Installation

CAN-BUS

The CAN-BUS is a digital connection to the CNC control. Optimum conditions are achieved with CNC controls and CAN components of LABOD electronic or CAN Open. Programming and operation by means of the control panel via the CAN-BUS. Interface complies with the standard ISO 11898. Adjustment and programming see Manual DS-CAN.

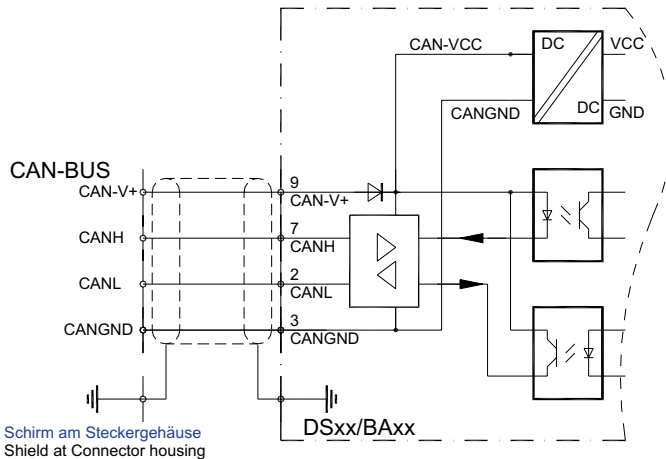

The CAN-BUS input is galvanically separated. The power supply is from the intern DC/DC

Pin assignment. Solder side.

CAN-BUS cable

Use a shielded bus conductor with a low shielding capacity. Signal plus GND (+supply). D-connector with a metal or metallized housing. LiYCY 4x0.25+shield.

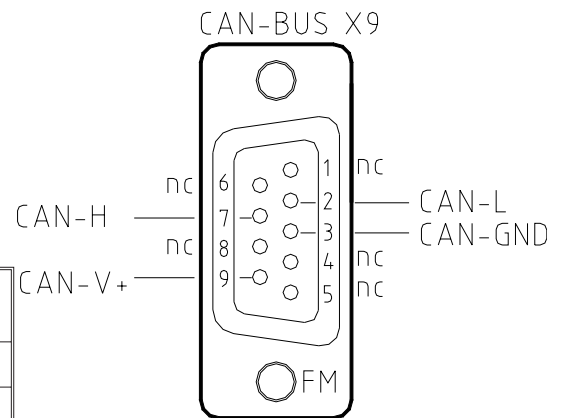

FM = Female Connector

| Designation | Connector no. | Cable colour | Cable no. |
|-------------|---------------|--------------|-----------|
| CAN-V+ | 9 | brown | 1 |
| CAN-GND | 3 | white | 4 |
| CAN-H | 7 | green | 3 |
| CAN-L | 2 | yellow | 2 |

CAN-BUS connection with several BAMOBIL-D3

Master Adresse xx Adresse xx Adresse xx

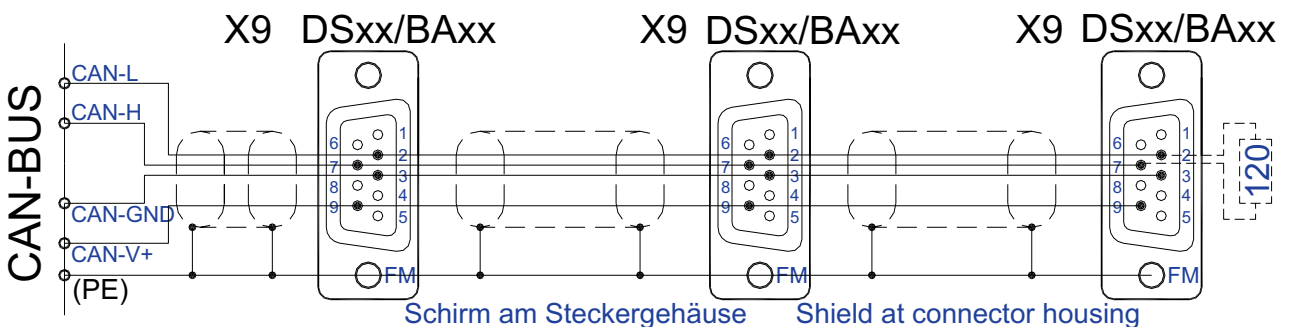

Terminating resistor at the end of the bus line > 120Ohm between the CAN-H and CAN-L

Resolver - connection.

Applicable only for DS 400-RS

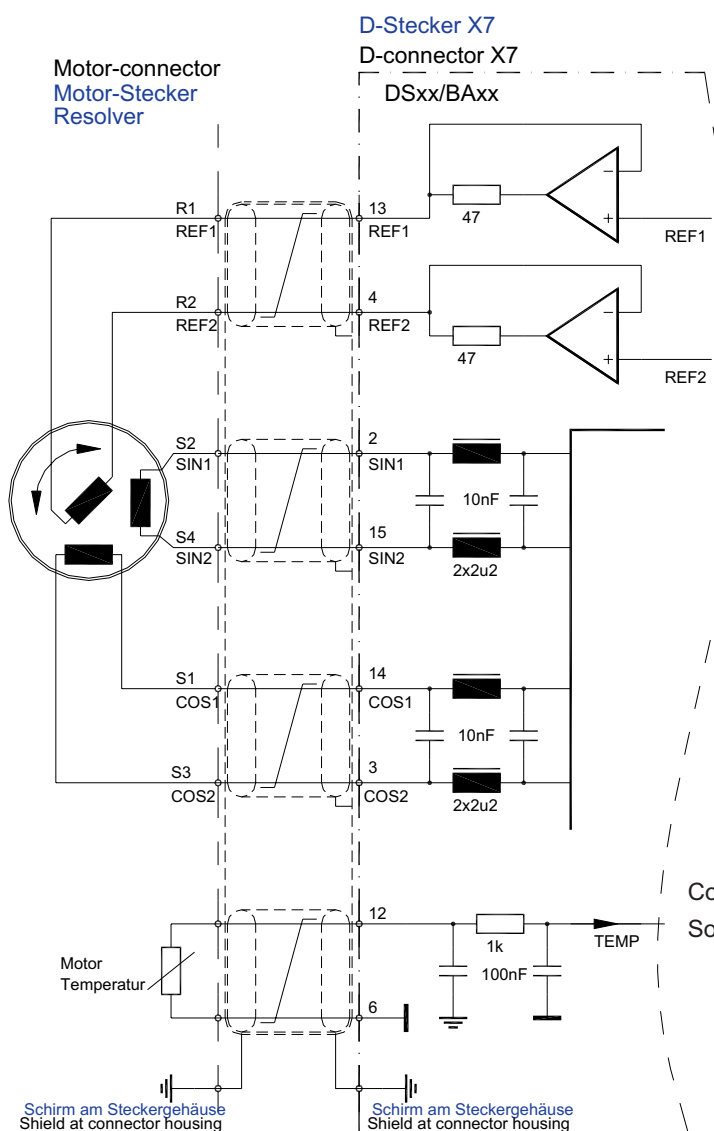

The resolver is an absolute measuring system for one motor revolution. It is rugged and not sensitive to high motor temperatures. Its set-up is like a rotating transformer. The rotor is fed by the reference (10kHz).

The stator provides the sinus and cosine signals modulated by the rotation reference.

The amplitudes of these signals are evaluated and digitalized in the servo amplifier.

The resolution is fixed to 12bit (4096 inc./rpm). The maximum possible rotational speed is 15600. The digitalized signals are used for the rotor angle, the position and speed control and for the incremental output. The absolute accuracy is approx. +/- 10 angular minutes.

Connect.assignment
Soldered side

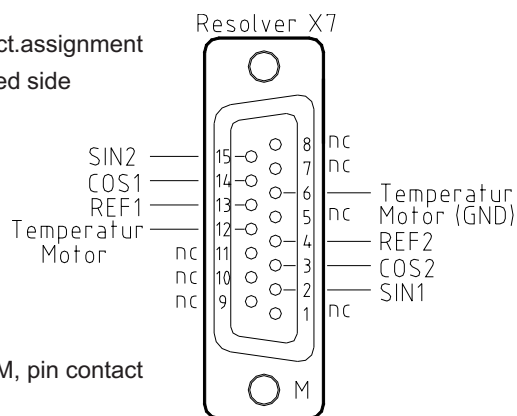

Only UNITEK approved motors (Appendix A) with 2,4 or 6 pole resolvers must be used.
Note motor-specific connection sheet!

- Connecting plug: X7 - 15pin D-plug
- Connecting lead: 4 Twisted pair, individually shielded plus outer shield.
For Link-chains, only suitable cable should be used.
- Cable length: For > 25m, use only high quality resolver cable with adequate shielding properties.
- Shielded connection: at plug X7 contact shield with the plug housing.
At the motor plug - contact shield with the plug housing.

For setup - parameters - see DS software manual

5 Electrical Installation

Encoder - connection.

Applicable only for DS 400 - IN

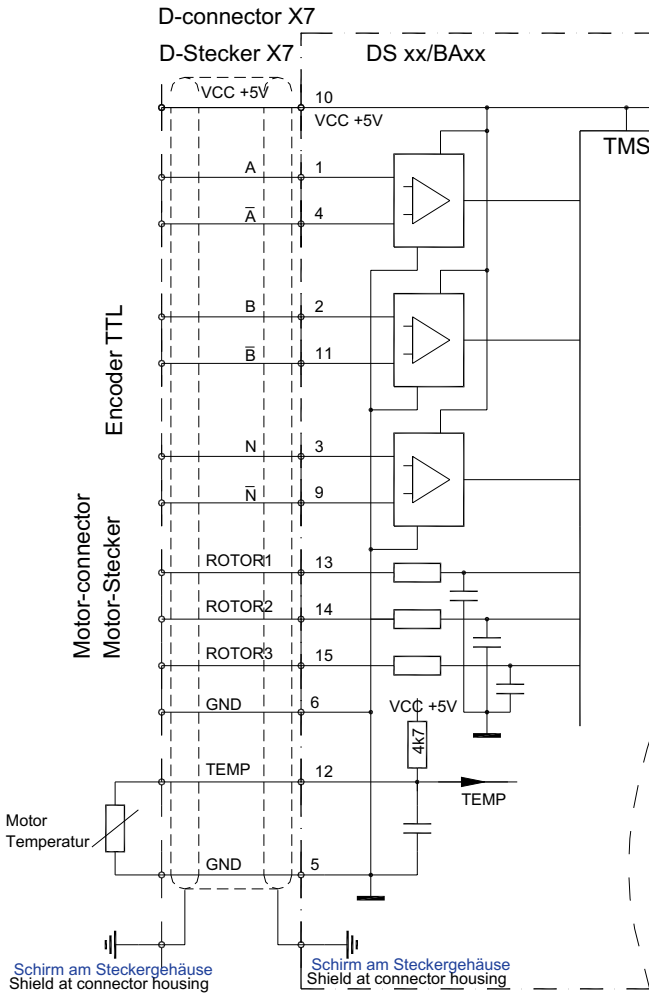

Incremental encoders with 2 counting tracks and a zero track plus 3 rotor position tracks. Counting tracks with push-pull output. Counting - input corresponds to RS485. Maximum counting frequency 500kHz.

The incremental encoder is galvanically coupled with the device - zero (GND) . Supply voltage 5V.

Connect.assignment
Soldered side

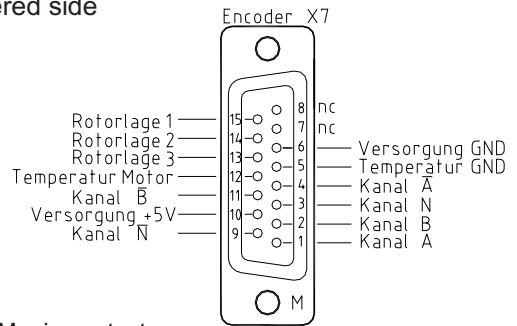

Only UNITEK approved motors (Appendix A) with incremental encoders.
Note motor-specific connection sheet!

- Connecting plug: X7 - 15pin D-plug
- Connecting lead: 10 signal wires, shielded, minimum cross section 0,14 mm
2 supply wires, minimum cross section 0, 5 mm.
Use only suitable cables in a power carrier chain.
- Cable length: The next step up for a section of >25m.
- Shielded connection: at plug X7 contact shield with the plug housing.
At the motor plug - contact shield with the plug housing.

For setup - parameters - see DS software manual

SIN / COS Connection

only for DS xx-SC

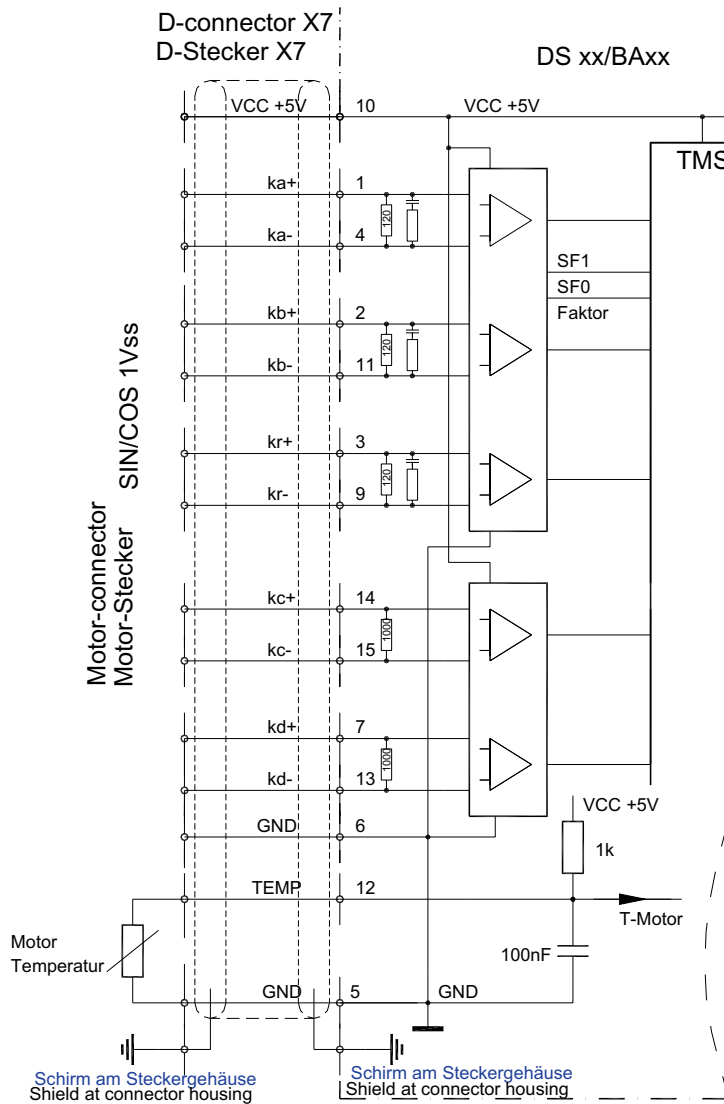

Incremental encoder with 2 analog sinusoidal counter tracks and 1 zero track plus 2 commutating tracks.
Differential inputs 1Vss

Max. counting frequency 500kHz

The incremental encoder is galvanically connected with device zero (GND).
Supply voltage 5V, provided by the servo.

The resolution is automatically adjusted to an optimum.

Connect.assignment Soldered side

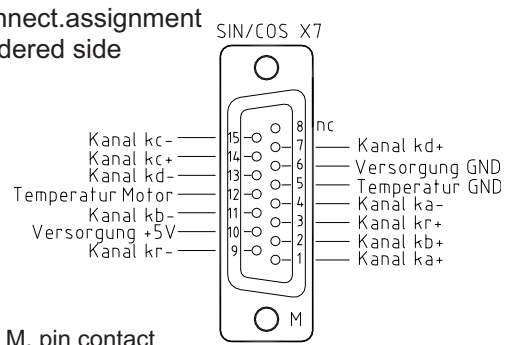

Use only motors with SIN/COS encoders (SC) which have been approved by UNITEK (Appendix A). Observe the motor specific connection data sheet (SC)!

| | |
|-------------------|----------------------------------------------------------------------------------------------------------------------------------------------------------------------------------------------------------------------|
| Connector | X7 15-pole D-connector |
| Connecting cable | 4 signal conductors, twisted and shielded, min. cross-section 0.14mm 2 signal conductors, shielded, min. cross-section 0.14mm 4 supply lines, temp., min. cross-section 0.5mm (4x(2x0.14)+(4x0.14)C+4x0.5)C |
| Cable type | For link chains use appropriate cables! |
| Cable length | for >25m the cross-section of the cable used must be increased by one grade |
| Shield connection | across connector X7-connect the shield to the connector housing across the motor connector - connect the shield to the connector |

5 Electrical Installation

Rotor position encoder - connection via a bl-tacho only for DS xx-bl

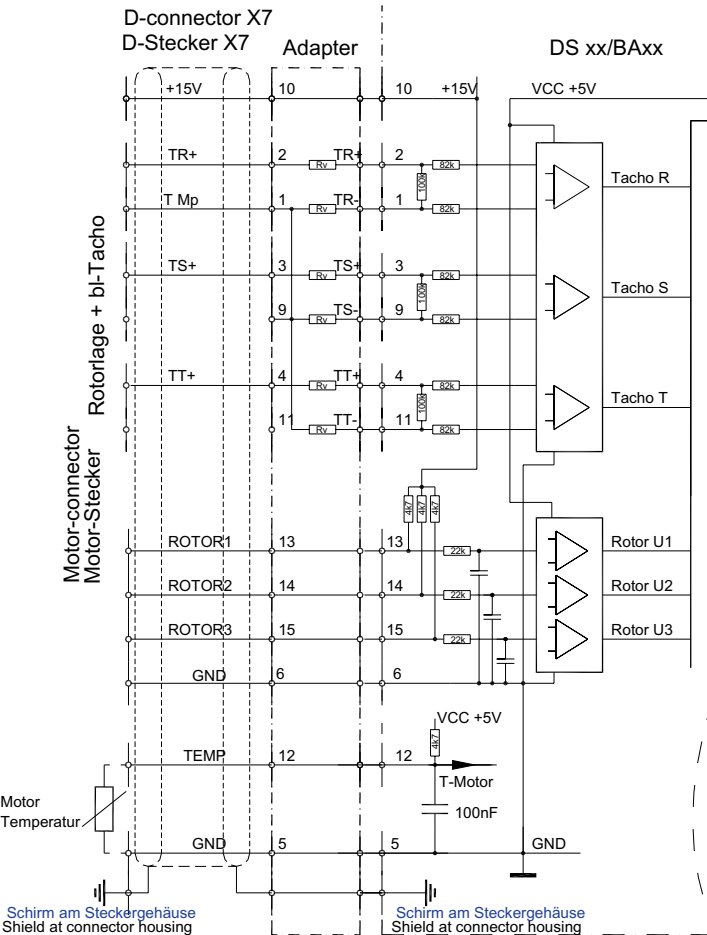

3 rotor position encoder signals (Hall sensors) for the commutation; with or without a brushless tacho.

The rotor position encoder is galvanically connected with the device zero (GND).

The voltage of 15V is supplied by the servo-drive.

Provide an adapter in case the tacho voltage at rated speed is superior to 10V~.

For lower tacho voltages connect X7: pin 1, 9, and 11.

Connect the tacho center point to X7:1.

Connect. assignmen

Soldered side

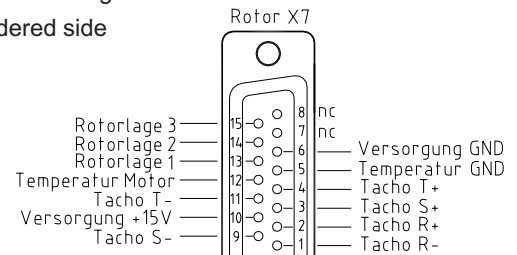

M, pin contact

Use only motors with Rotor encoders (bl) which have been approved by UNITEK (Appendix A). Observe the motor specific connection data sheet (bl)!

Connector X7 15-pole D-connector
 Connecting cable 4 signal conductors, twisted and shielded, min. cross-section 0.14mm
 2 signal conductors, shielded, min. cross-section 0.14mm
 4 supply lines, temp., min. cross-section 0.5mm

Cable type (4x(2x0.14)+(4x0.14)C+4x0.5)C

For link chains use appropriate cables!

Cable length for >25m the cross-section of the cable used must be increased by one grade

Shield connection across connector X7-connect the shield to the connector housing across the motor connector - connect the shield to the connector housing.

X8 TTL- Encoder output or input (2)

The D connector X8 is connected as input or output (default).

Output X8 pin 6 not connected or bridge to GND

Input X8 pin 6 bridge to +5V (X8:1)

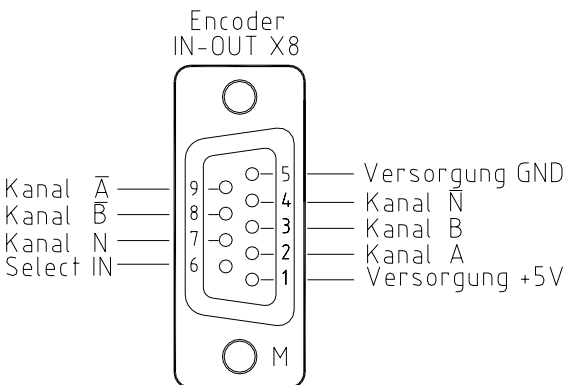
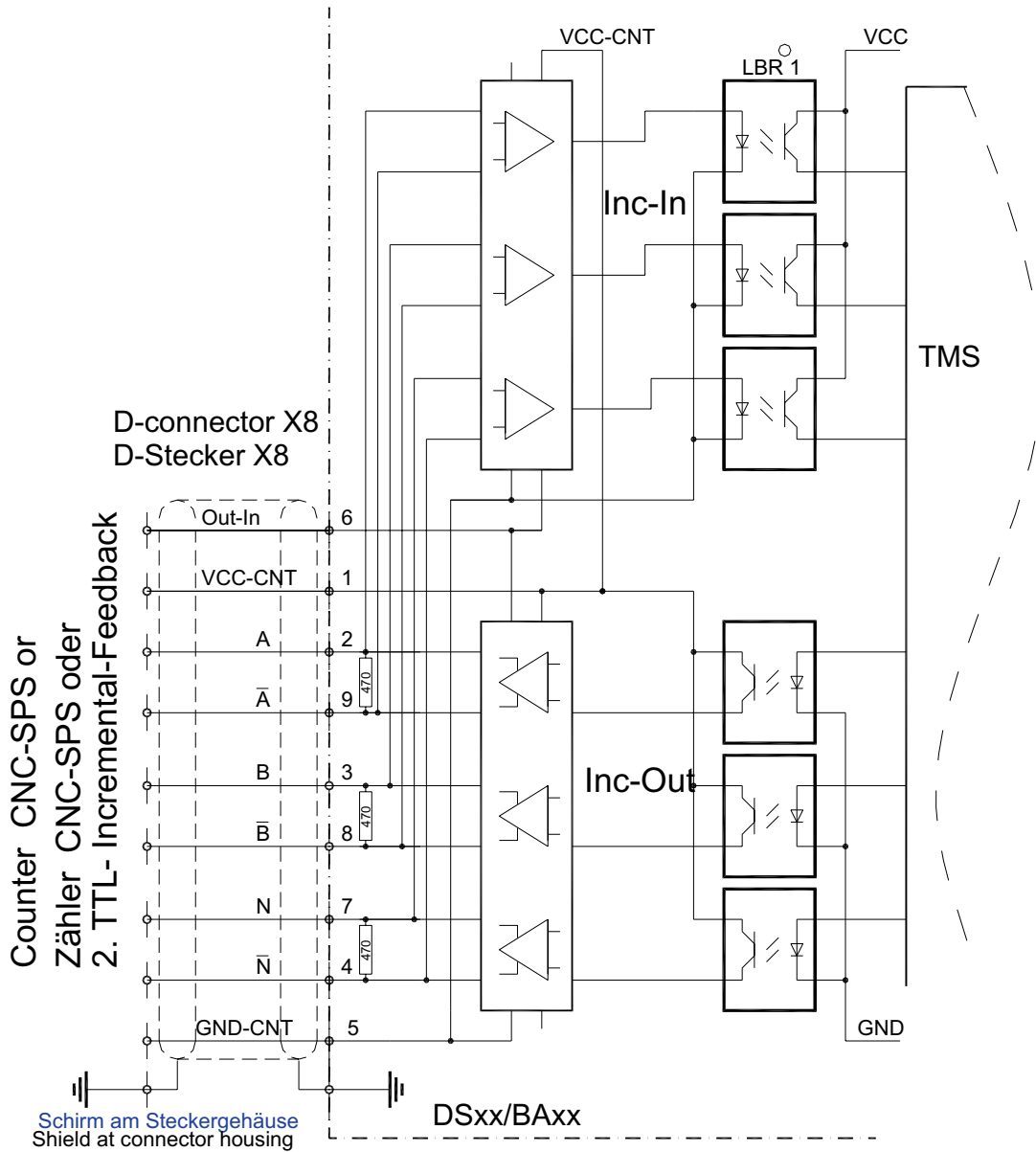

9-pin D connector (M, pins)

Connector assignment soldering side

Attention: X8 as input

X8:6 (Select IN) with X8:1 (+5V) connect with the D connector

5 Electrical Installation

X8 as TTL Encoder output

The encoder signals supplied by the motor (feedback) are available at the output of the D-connector X8 for the CNC control.

The encoder output is internally isolated.
The voltage is supplied via the encoder line from the CNC/PLC control.
Voltage supply +5V ±0.2V.
The output signal corresponds to RS485.

Option: Internal supply from the servo (LBR1 + LBR2)

For RS and SC the resolution can be programmed (parameter 0xa4), Bit1).
For IN it is equal to the number of encoder pulses.

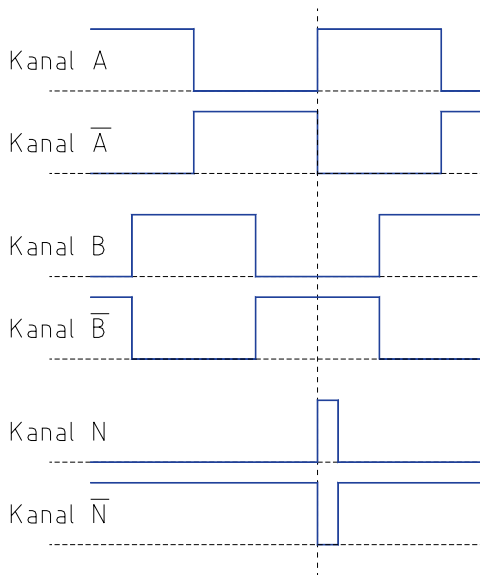

Pulse signals (motor revolving clockwise)

| | |
|------------------|-----------------------|
| Output level | low <0.5V, high >4.5V |
| Slope | <0.1ms |
| Zero pulse | min. 0.2ms |
| Output frequency | max. 200kHz |
| Pulse/rpm | |
| - for RS, SC | programmable |
| - for IN | encoder no.of pulses |

X8 as TTL Encoder input

Attention: X8 pin6 (select IN) and X8 pin1 (+5V) must be bridged!

The encoder input is internally isolated.
The voltage is supplied via the encoder line.
Option: Internal supply from the servo
The input signals correspond to RS485.
Input frequency: max. 200kHz

Option: Internal supply from the servo (LBR1 + LBR2)

The encoder input can be programmed to fulfill different functions.







LED displays on the Servo

The state “**normal**” is signalled by a bright green seven-segment display + decimal point (display of the state).

The state “**fault**” is signalled by a bright red fault LED and the seven-segment display indicates the error no.

The state “**warning**” is signalled by the flashing red fault LED and the seven-segment display indicates alternately the state and the warning no.

Display of the servo-drive state

| Display | Point/segment | State | State of NDrive |
|-------------------------------------------------------------------------------------|-----------------|------------------------------------------------------------------------------------------------------|-----------------|
|  | flashing | Processor active | |
| | dark | Auxiliary voltage missing or inherent hardware failure | |
|  | flashing | Starting state after reset (auxil. voltage 24V off-on). The first enable stops the flashing display. | OK = 0 |
| | bright | Drive enabled | OK = 1, ENA = 1 |
|  | dark | Drive disabled (not enabled) | OK = 1, ENA = 0 |
| | bright | Speed zero (standstill signal) | N0 = 1 |
|  | bright | Drive revolves clockwise, N currently positive | N0 = 0 |
| | flashing | Motor current reduced to continuous current I_{cns} | $I_{cns} = 1$ |
|  | bright | Motor current at max. current limit I_{max} | $I_{cns} = 0$ |
| | dark | Normal operation; Motor current within the current limits | $I_{cns} = 0$ |
|  | bright | Drive revolves anti-clockwise, N currently negative | N0 = 0 |
|  | bright for 0.1s | A new command (value) was received from the BUS or RS232 | |

Example: Motor revolving clockwise



Point flashes = active processor
 bottom segment = drive enabled
 right segment = motor revolves clockwise

5 Electrical Installation

Error message on the Servo

In case of an error the red LED 'fault' lights up and the green 7-segment display indicates the error number.

Error list

| Display on the Servo | Error message on the NDrive | Description |
|------------------------|------------------------------------------------------|----------------------------------------------------|
| 0 | BADPARAS | Parameter error |
| 1 | POWER FAULT | Output stage error |
| 2 | RFE FAULT | Error in the safety circuit |
| 3 | BUS TIMEOUT | Transfer error BUS |
| 4 | FEEDBACK | Incorrect/faulty encoder signal |
| 5 | POWERVOLTAGE | No power supply voltage |
| 6 | MOTORTEMP | Motor temperature too high |
| 7 | DEVICETEMP | Device temperature too high |
| 8 | OVERVOLTAGE | Over voltage >1.8 x UN |
| 9 | I_PEAK | Overcurrent 300% |
| A | RACEAWAY | Racing (without command value, incorrect polarity) |
| B | USER | User's error choice |
| C | RESERVE | |
| D | RESERVE | |
| E | CPU-ERROR | Software error |
| F | BALLAST | Ballast circuitry overload |
| Flashing decimal point | Active processor | |
| Dark decimal point | Missing auxiliary voltage or device hardware failure | |

Example:



FAULT LED
Error no. 5

red
Power voltage (missing power voltage)

DEVICETEMP

Error message when DS450.
In DS405, 412.420, the IGBT over temperature
as an error 1 POWER FAULT (error amplifier) reported

Warnings

The warning messages are displayed in the window 'warnings'.

Warning messages

| Warning display | Warning message on the NDrive | Description | ID-address |
|-----------------|-------------------------------|---------------------------------------|-------------|
| | | | 0x8f |
| 0 | | | Bit 16 |
| 1 | | | Bit 17 |
| 2 | | | Bit 18 |
| 3 | | | Bit 19 |
| 4 | | | Bit 20 |
| 5 | POWERVOLTAGE | Leistungsspannung zu klein oder fehlt | Bit 21 |
| 6 | MOTORTEMP | Motortemperature > 87% | Bit 22 |
| 7 | DEVICETEMP | Devicetemperature > 87% | Bit 23 |
| 8 | OVERVOLTAGE | Overvoltage >1,5 x UN | Bit 24 |
| 9 | I_PEAK | Overcurrent 200% | Bit 25 |
| A | | | Bit 26 |
| B | | | Bit 27 |
| C | I2R | Power overload > 87% | Bit 28 |
| D | | | Bit 29 |
| E | | | Bit 30 |
| F | Regen | Regen > 87% overload | Bit 31 |

LED displays on the servo

In case of a warning state the red LED changes (low-frequency) and the seven-segment display shows alternately the warning no. (red LED) and the operating state (LED dark).

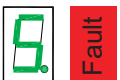

Example:

The red fault LED flashes and the display shows alternately the warning number and the operating state.

Warning no. 5 = POWERVOLTAGE

Guarantee

UNITEK guarantees that the device is free from material and production defects. Test results are recorded and archived with the serial number.

The guarantee time begins from the time the device is shipped, and lasts one year. Unitek undertakes no guarantee for devices which have been modified for special applications.

During the warranty period, UNITEK will, at its option, either repair or replace products that prove to be defective, this includes guaranteed functional attributes. UNITEK specifically disclaims the implied warranties or merchantability and fitness for a particular purpose. For warranty service or repair, this product must be returned to a service facility designated by UNITEK.

For products returned to UNITEK for warranty service, the Buyer shall prepay shipping charges to UNITEK and UNITEK shall pay shipping charges to return the product to the Buyer.

However, the Buyer shall pay all shipping charges, duties, and taxes for products returned to UNITEK from another country.

The foregoing warranty shall not apply to defects resulting from:

- * improper or inadequate repairs effected by the Buyer or a third party,
- * non-observance of the manual which is included in all consignments,
- * non-observance of the electrical standards and regulations
- * improper maintenance
- * acts of nature

All further claims on transformation, diminution, and replacement of any kind of damage, especially damage, which does not affect the UNITEK device, cannot be considered.

Follow-on damage within the machine or system, which may arise due to malfunction or defect in the device cannot be claimed.

This limitation does not affect the product liability laws as applied in the place of manufacture (i. e. Germany).

UNITEK reserves the right to change any information included in this MANUAL.

All connection circuitry described is meant for general information purposes and is not mandatory.

The local legal regulations, and those of the Standards Authorities have to be adhered to.

UNITEK does not assume any liability, expressively or inherently, for the information contained in this MANUAL, for the functioning of the device or its suitability for any specific application.

All rights are reserved.

Copying, modifying and translations lie outside UNITEK's liability and thus are not prohibited. UNITEK's products are not authorised for use as critical components in the life support devices or systems without express written approval.

The onus is on the reader to verify that the information here is current.