

MANUAL
3-phase Transistor Servo-Drive

TVD6-200bl, TVD6.2-400-bl

for brushless DC Motors
with Rotor Position Encoder

TVD6-bl, TVD6.2bl

UNITEK

Industrie Elektronik
G m b H

Hans-Paul-Kaysser-Strasse 1
D-71397 Leutenbach 3 - Nellmersbach

Tel.: 07195/9283-0
Fax 07195/928329
email info@unitek-online.de
Http// www.unitek-online.de

Version
0108-1

Contents	Page
1. Basic Information	
Safety advice	3
Standards and guidelines	3
General information	4
Applications	5
Features	6
Technical data	7,8
2. Mechanical installation	
Dimensions	9,10
Build	11
Mounting advice	12
3. Electrical installation	
Connections	13,14
Earthing diagram	15
EMC advice	15
Power connections	16,17
Connection to the TT and IT mains	18
Motor power connections	19
Control connections	20-25
Signal outputs	26, 27
Terminal connections and connectors	28, 29
4. Device overview	
Components	30
Circuit diagram	31
Front panel	32
Adjustments	33
LED signals	34
5. Adjustments	
Adjustment advice	35
Command value	36
Speed actual value	37
Current limiting	38
Speed control loop circuit	39-41
6. Commissioning	
Basic set-up	42
Commissioning	43
7. Faults	
LED displays - faults	44
Fault diagnosis	45
Pulse signals - test point connector X4	46
Encoder signals	47
8. Guarantee	48
9. Protocol	49, 50
10. Drawings	51, 52

Electronic equipment is not fault proof. This fact should be borne in mind for all possible operating conditions.

Attention High voltage

TVD6bl **AC 250V~, DC 420V=**
TVD6.2bl **AC 400V~, DC 800V=**

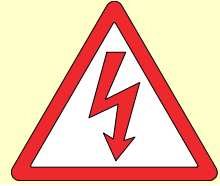

Before installation or commissioning begins, this manual must be thoroughly read and understood by the technical staff involved. If any uncertainty arises, the manufacturer or dealer should be contacted. TVD6 devices are power electric parts used for regulating energy flow for power plants. Protection rating IP00.

Standards and guidelines

The device and its associated components can only be installed and switched on where the local regulations and technical standards have been strictly adhered to:

- EU Guidelines 89/392/EWG, 84/528/EWG, 86/663/EWG, 72/23/EWG
 EN60204, EN50178, EN60439-1, EN60146, EN61800-3
- IEC/UL IEC364, IEC 664, UL508C, UL840
- VDE Regulations VDE100, VDE110, VDE160
- TÜV Regulations
- Trade body guidelines: VGB4

The user must ensure that in the event of :

- device failure
 - incorrect operation
 - loss of regulation or control
- the axis will be safely de-activated.

It must also be ensured that the machine or equipment are fitted with device independent monitoring and safety features.

Setting adjustments

- should only be carried out by suitably trained personnel
- should only be carried out in accordance with health and safety guidelines

Assembly

- should only be carried out when all voltages have been removed.

QS

Test results are archived with the device serial number by the manufacturer.

CE

The device adheres to the following: Guideline EU 89/336/EWG. EMV standards EN61000-2 and EN61000-4.

General Information

The transistor 3-phase current servo amplifier **SERVO-TVD6 and TVD6.2** in combination with the brushless dc motor (synchro servo motor, CE motor) provide a drive solution free of maintenance and with a wide dynamic control range. The drive displays the well-known good control characteristics of dc drives without the disadvantages of the carbon brushes' wear and the commutation limits. The rotor moment of inertia is notably lower and the limit power is greater than with equally constructed dc motors. This results in up to 5 times higher acceleration values. The generated heat in the motor only occurs in the stator, therefore, the bl-motors always have the protection rating IP 65.

From the electrical view, the brushless dc motor is a synchro motor with a permanent magnet rotor and a three-phase current stator.

The physical characteristics correspond to those of dc motors, i.e., the current is proportional to the torque and the voltage is proportional to the speed. Current and voltage are precisely measured, thus the analog circuits are simply constructed.

It is possible to control the speed via the motor voltage, however, in order to achieve the best control precision, a tacho control is always used. The speed actual value is generated in the encoder unit (rotor position encoder plus brushless tacho). The difference of the command value and the actual value is amplified in the speed control loop circuit (P-I-controller) of the servo drive. This results in the current command value, which is transferred to the three phase-current controllers by means of the rotor position signal. In the course of this the stator magnetic field leads the rotor magnetic field by 90° electrically.

This field frequency is not controllable, it is automatically adjusted.
The motor currents are trapezoidal.

For dc, ac, or bl-servo amplifiers which are supplied by a dc bus, it must be checked that the energy is fed back into the bus during brake operation (winding machines, lifts, great centrifugal masses).

The ballast circuitry is rated for 3% duty cycle. An extended operating time can be achieved by additional external resistors.

Information:

For motors	with incremental encoder	UNITEK TVD3-2-xx-IN
	with resolver	UNITEK TVD3-2-xx-RS
	with bl-tacho	UNITEK TVD3-2-xx-bl
For low-voltage applications		UNITEK TVD3-230-xx-bl UNITEK TVD3-230-xx-IN UNITEK TVD3-230-xx-RS
For high power		UNITEK TVD6-2 -bl,IN,RS 200V/400V up to 25/40A
For digital servo controllers		UNITEK DS400 200V/400V up to 50/100A

Applications

Machines and installations for all types with a drive power of

4 kW using TVD6-200bl

8 kW using TVD6.2-400bl,

especially as 4Q-servo-drive for feed axes where the following is required:

- high dynamic acceleration and braking cycles
- a wide control range
- high efficiency
- small motor dimensions
- highly repeatable, accurate and quiet moves

For speed or torque control or combined speed/torque control incorporated within or independent of position control loops.

Drives with constant speed as in conveyors, spindle drives, pumps, transversal or longitudinal pitch drives.

Synchro-servo-drives are more compact than other electric drives.

Particularly suitable for:

component equipment inserting machines, sheet-metal working machines, machine tools, plastic working machines, assembly machines, knitting and sewing machines, textile working machines, grinding machines, wood and stone working machines, metal working machines, food processing machines, robots and handling systems, conveyors, extruders, calenders, and many other machines and installations.

Note:

Bl-drives where braking operations are predominant, e.g. when deceleration is mainly required:

- winding machines, lifts, great centrifugal masses

The braking energy is annihilated in the ballast circuitry or fed into the mains through the use of an external dc bus converter.

Energy compensation is possible for drives with several axes.



Motor features

- protection rating IP 65
- compact
- suitable for rough surroundings
- suitable for high dynamic overload
- free of maintenance

Build

- switch cabinet mounting or 6HE plug-in device according to the VDE, DIN and EU regulations
- standard analog control electronics
- power electronics for 10A, 16A, and 25A
- wide-band chopper power supply unit for the auxiliary voltages
- power section on the rear panel

Galvanic isolation between

- the power section and the housing
- the power section and the control electronics
- the control electronics and the logic inputs

The distance of air gaps and leakage paths adhere to the VDE standards.

Components

- fully insulated six-pack IGBT power semiconductors, comfortably over-dimensioned
- only components customary in trade and industrially standardised are used
- high-quality bases for the IC with external connections
- LED displays
- 16-position binary switches for the P-I adjustment of the speed controller
- precision potentiometers for fine adjustments
- plug-in jumpers for the system set-up

Characteristics

- * TVD6-200bl: connection directly to the mains 230V~
- * TVD6.2-400bl: connection directly to the mains 400V~
- * electronic limitation of the switch-on current
- * 2 differential command value inputs
- * start-up and braking ramp for the 2nd command value
- * speed and torque control
- * static and dynamic current limiting
- * current command value output
- * measurement points for current and speed
- * optically de-coupled logic inputs and outputs
- * logic for enable and the output stage switch
- * switch-off of the integral function
- * emergency stop
- * braking in case of a mains failure
- * temperature watchdog for the motor and the device
- * solderless parameter adjustment
- * 10-pin test point connector

1 Basic Information

Technical Data

Power connection TVD6-200bl:

directly to the mains

using an auto-transformer

1 x 230V~ ± 10%

3 x 230V~ ± 10%

Option: for voltages < 180V~ >> please inquire

Specification					
Servo amplifier TVD6-200		10	16	25	
Output voltage	V~eff.	200	200	200	
Stationary current output	- continuous	A=	10	16	25
	- peak	A=	20	32	40
Max. el. power	kW	2	3.2	5	
Integrated quick ZW fuses	A	20	20	20	
Dimensions: - compact device	wxhxd	see dimension sheet			
- plug-in unit	wxh	16TE/6HE	16TE/6HE	24TE/6HE	
Cooling	at 60% duty cycle		self	self	external
	at 100% duty cycle		external	external	external

Power connection TVD6.2-400bl:

directly to the mains

1 x 400V~

3 x 400V~

max. 460V~

Option: for voltages < 300V~ >> please inquire

Specification:						
Servo amplifier TVD6.2-400-		5	10	16	25	
Output voltage	V~eff.	400	400	400	400	
Stationary current output	- continuous	A=	5	10	16	25
	- peak	A=	10	20	32	40
Max. el. power	kW	2	4	6,4	10	
Integrated quick ZW fuses	A	20	20	20	20	
Dimensions - plug-in unit wxh	6HE	16TE	16TE	16TE	24TE	
Cooling	at 60% duty cycle	external	external	external	external	
	at 100% duty cycle	external	external	external	external	
Switch cabinet plug-in module	wxhxt	see dimension sheets				

Technical Data

Common specification

Protection rating	IP 00
Format	VDE 0100 group C, VDE 0160
Humidity rating	class F acc. to DIN 40040
Site of installation	< 1000m above sea level
Operating temperature range using external fans)	0 to 45°C (0 to 35°C when
Extended operating temp. range	up to 60°C reduced by 2%/°C
Storage temperature range	-30°C to +80°C
Speed control loop circuit	
control precision without act.value error	± 0.1%
control range	>1: 1000
Command value inputs	± 10V=
Logic inputs	+10 to +30V=
Logic inputs	>+14V, 6mA

Note:

Necessary information to be indicated when ordering TVD6-200bl:



Check the switch-on time	>>> external fan for 100% duty cycle
Multiple 16A axes on one rack	>>> use an external fan
Precise torque control	>>> current controller as P-I loop circuit
Large centrifugal mass	>>> external ballast resistance >27Ω

Necessary information to be indicated when ordering TVD6-400bl:

Check the switch-on time	>>> external fan for 100% duty cycle
Multiple axes with ≥10A on one rack	>>> use an external fan
Precise torque control	>>> current controller as P-I loop circuit
Large centrifugal mass	>>> external ballast resistance
Input voltages	

Multiple - axes combination

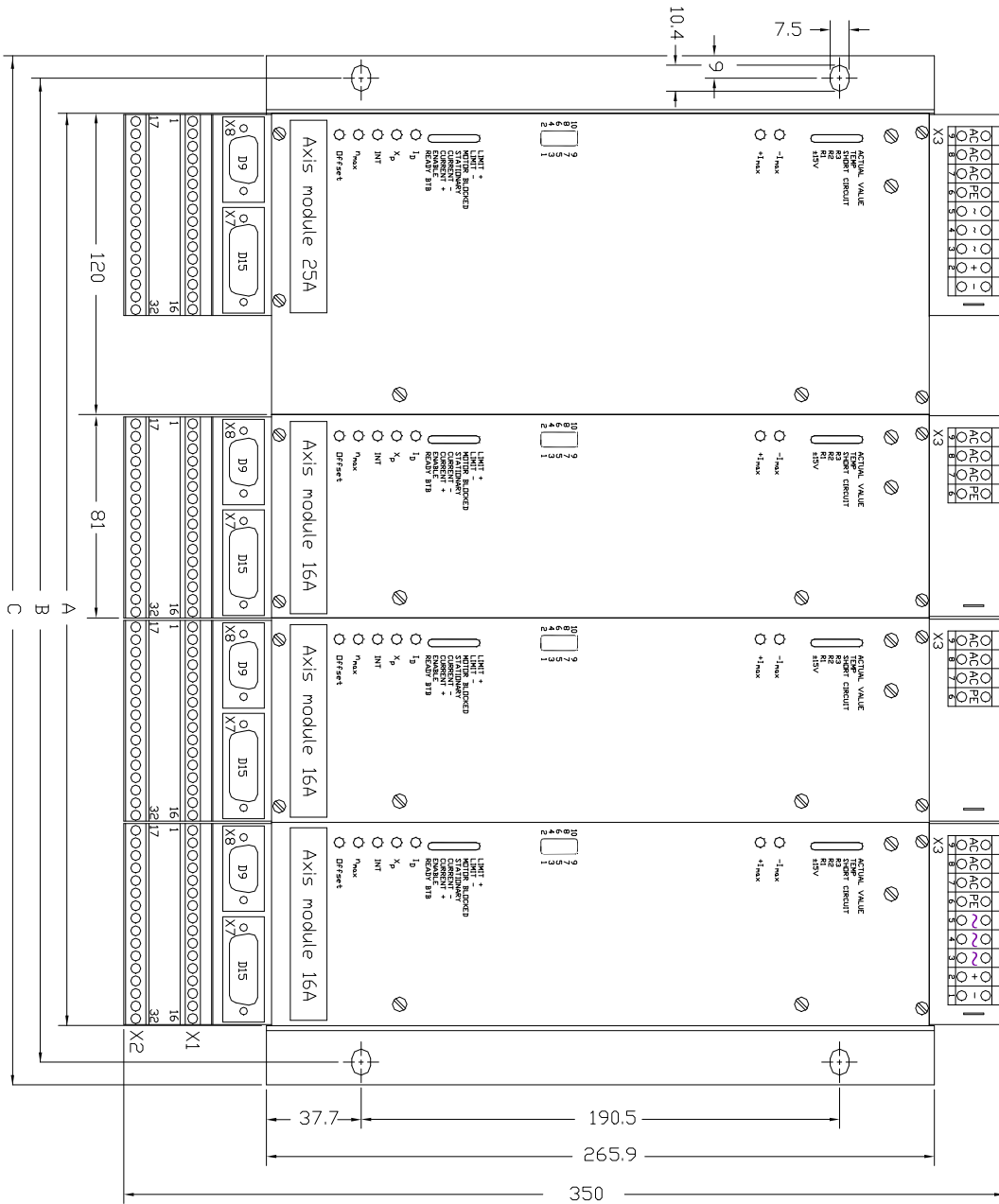

Dimensions 6HE [mm]					
Dimensions of the modules	1	2	3	4	5
A	1xE+3	2xE+3	3xE+3	4xE+3	5xE+3
B	1xE+40	2xE+40	3xE+40	4xE+40	5xE+40
C	1xE+55	2xE+55	3xE+55	4xE+55	5xE+55
Device frame					
E	for <= 16 A >>> 81.28 mm				
E	for 25A >>> 121.92 mm				
Mounting depth 255 mm					

For front mounting the lateral angle bracket is to be fixed on the front side, for wall mounting it is to be fixed on the rear side.

2 Mechanical Installation

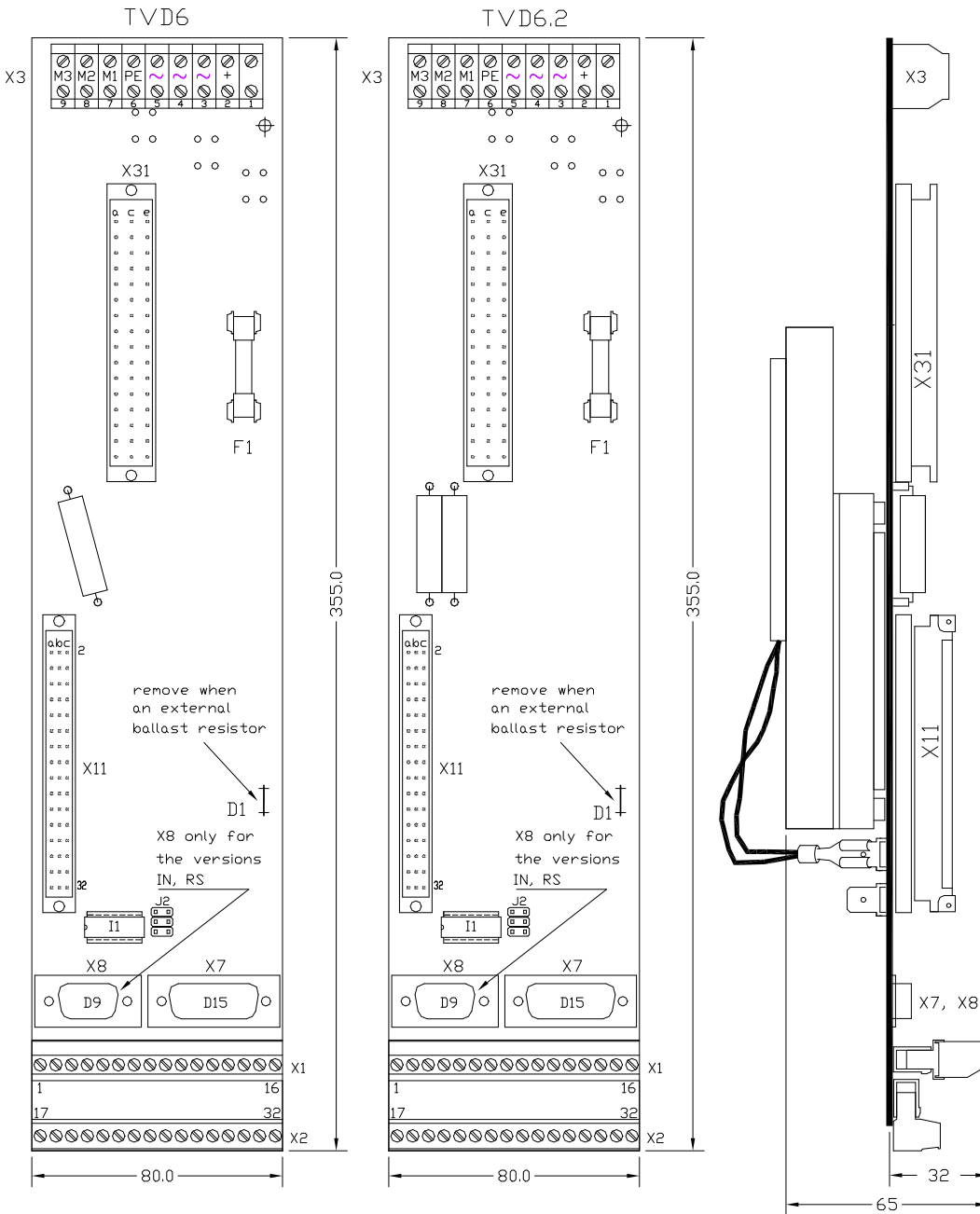

Rear panel of the mains module

with the module insertion (without supporting frame)

Mains module adjustments
external ballast resistance

bridge D1 open

Supporting frame

Height units:

6HE

Splitting units:

10/16A = 16TE, 25A = 24TE

Mixed 6HE, 3HE (TVD3.2):

supporting frame on request

Mounting depth 255mm

**Compact device 10/16A
Compact device 25A (w)**

**Compact device 25A (sw)
Multiplex axes combination**

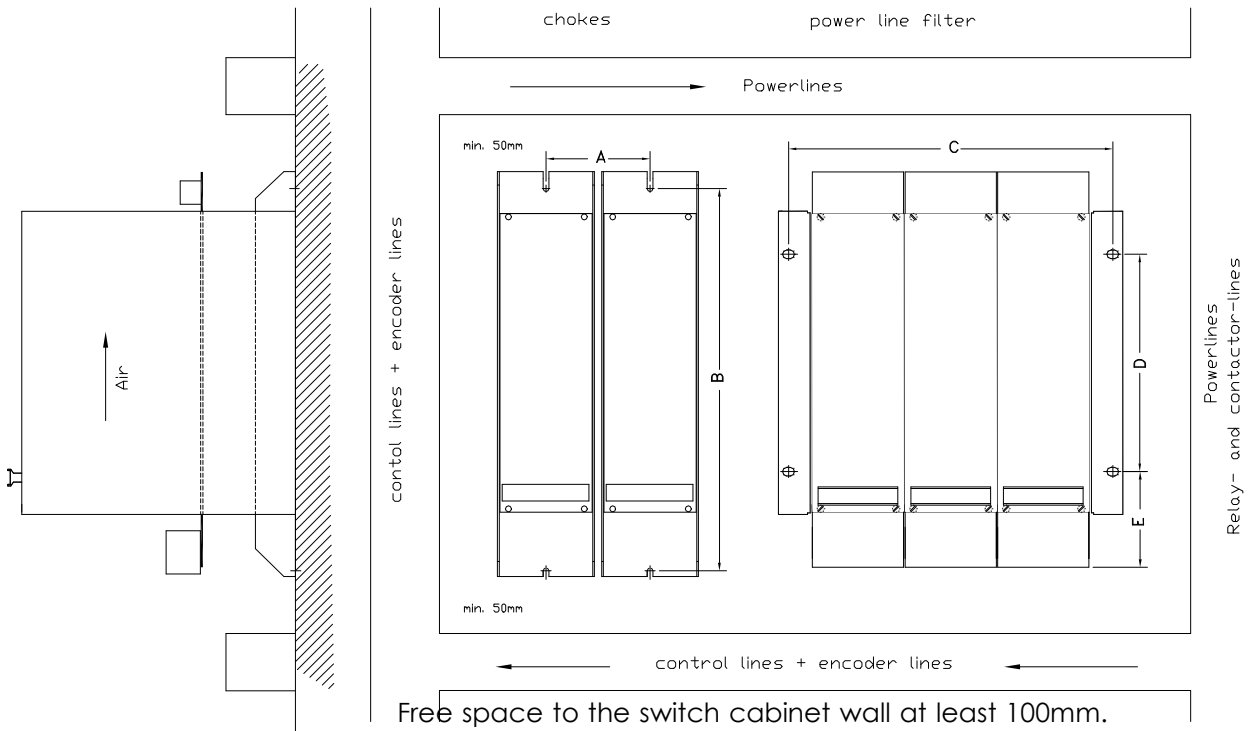

Bore hole dimensions of the compact devices [mm]						
Current	A	B	C	D	E	Screw
10, 16 case	95	335				M4
25-w case	135	335				M4
25-sw lat.angle bracket	180		158	190.5	55	M5

Bore hole dimensions of the multiple axes combinations [mm]					
Lateral angle bracket	A	C	D	E	Screw
Wall mouting	$n \times E+60$	$n \times E+40$	190,5	55	M5
Front mounting bei 19" systemen					
E for $\leq 16A = 81.28$ mm					
E for 25A = 121.92 mm					
n = No. of axis modules					

Power loss at max. power					
Device current	Power loss [W]		Fuse	M-choke	Filter
	Amplifier	Mains module			
5A	70	20	xx	xx	xx
10A	90	20	xx	xx	xx
16A	125	30	xx	xx	xx
25A	180	43	xx	xx	xx

3 Electrical Installation

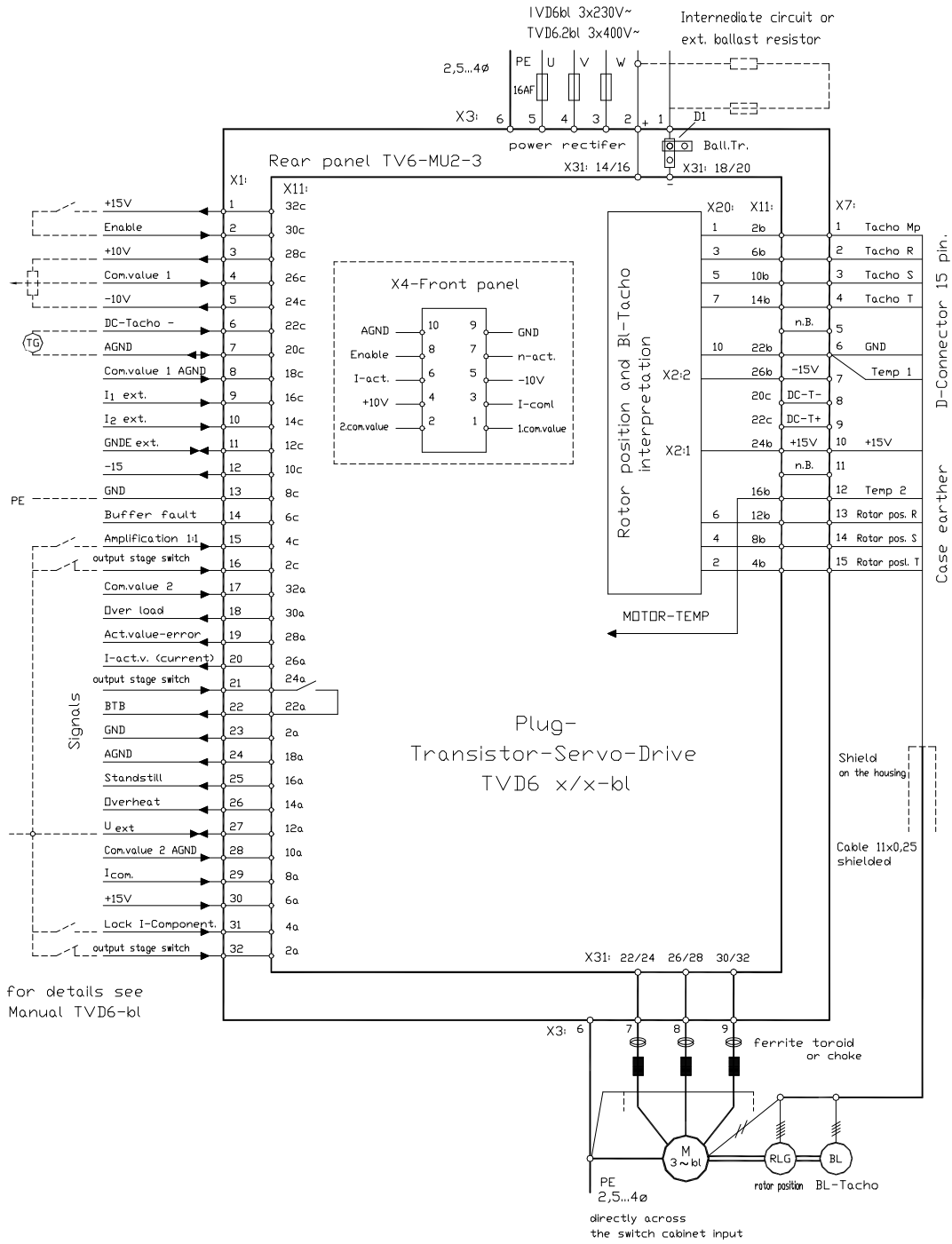

Device current	Power line filter		Motor choke TVD6-200	Motorchoke TVD6.2-400	Magnetic core
	1ph	3ph			
5A	FE1-10	FE3-10	-	MDD 1,3a	EMI742 70107
10A	FE1-16	FE3-16	MD78-10	MDD 1,6a	EMI742 70107
16A	FE1-16	FE3-16	MD84-20	MDD 2 b	EMI742 70107
25A	—	FE3-25	MD84-30	MDD 2,5b	EMI742 70107

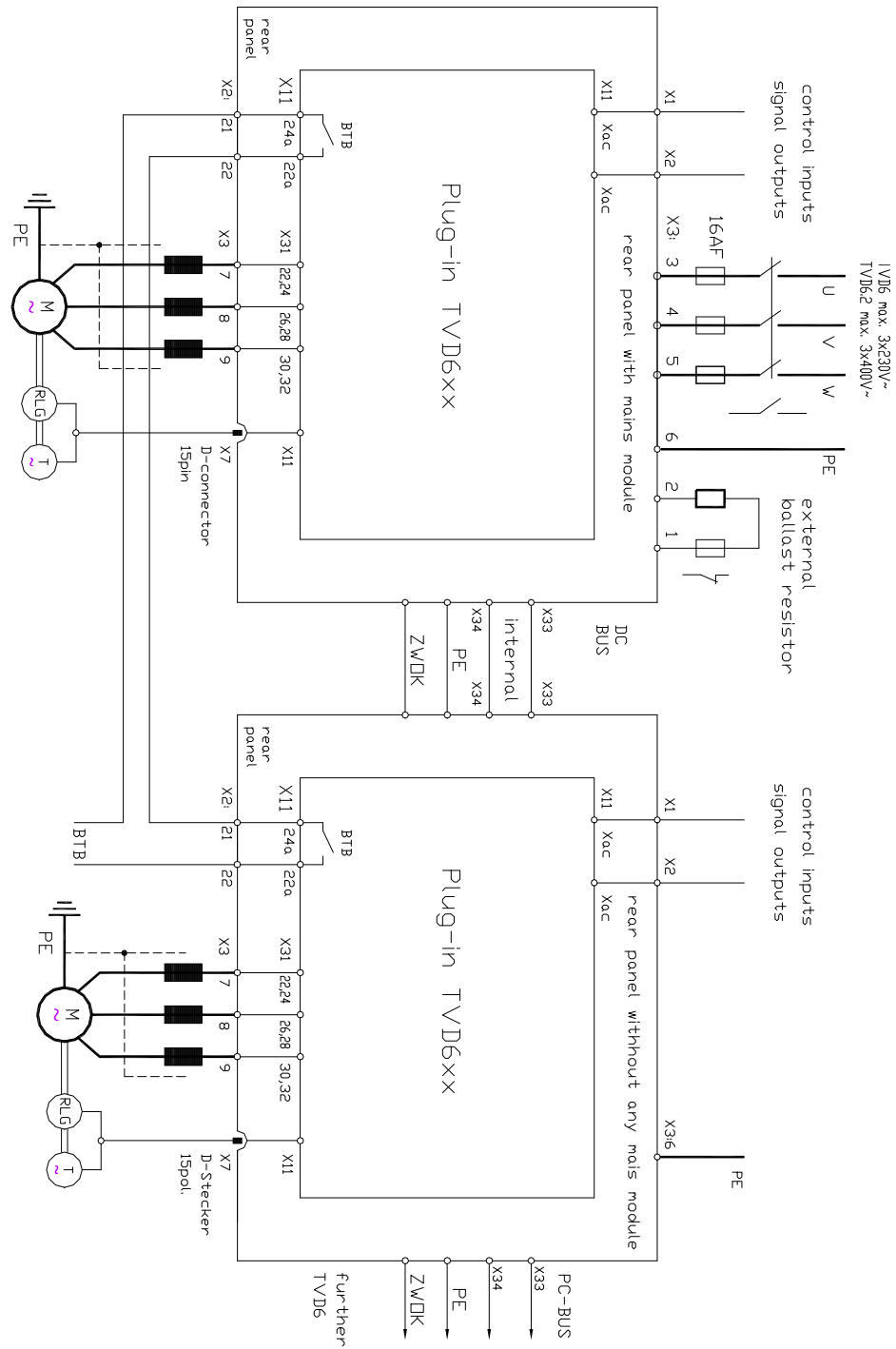

Compact device connection:

only left figure without internal connections

Multiple-axis combination:

one or multiple axis with a mains module plus one or multiple axis without any mains module;
optional position of the mains module

Connections

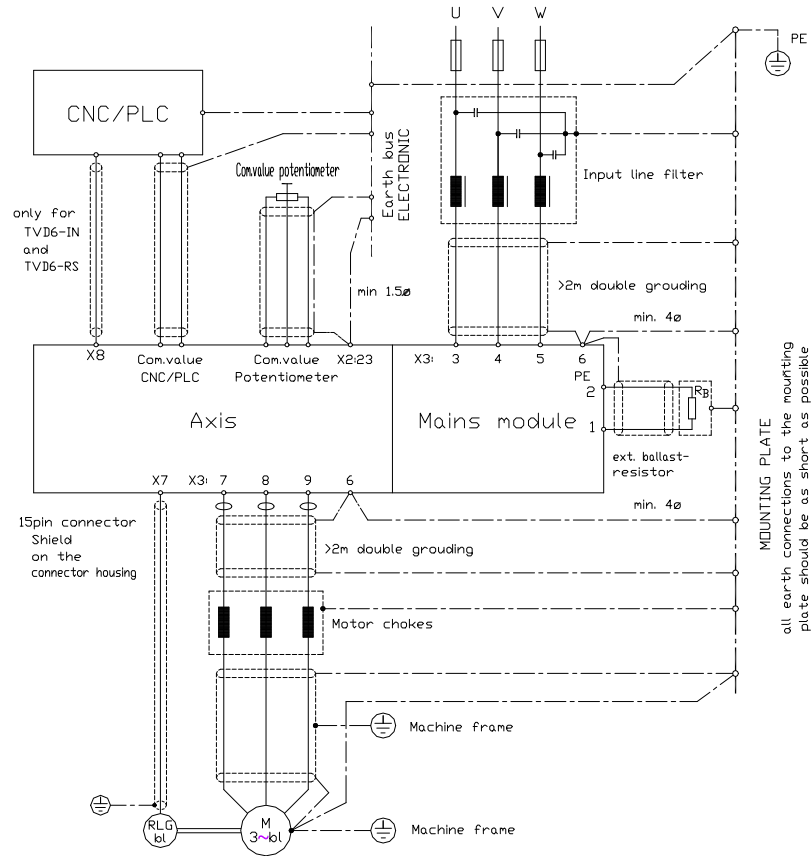

The devices adhere to the EU guidelines 89/336/EWG and the technical standards EN 610001-2 and 61000-4 provided that the following conditions are observed:

- The device, the transformer, motor chokes and power line filter are conductively mounted on a 500x500x2 mm mounting plate.
- The mounting plate must be connected to ground using a 10mm² wire.
- The motor housing must be connected to ground using a 10mm² wire.
- The device ground X1:13 must be connected to the mounting plate using a 2.5mm² wire.
- Device PE screw must be connected to the mounting plate using a 4mm² wire, l = 50mm.

Single-phase connection:

Power line filter type : up to 16A = FE1-16

Conductor length between the device and the power line filter <100mm

Three-phase connection:

Power line filter type : up to 16A = FE3-16

up to 25A = FE3-25

Conductor between the transformer and the power line filter <500mm.

Conductor between the device and the power line filter <100mm.

Motor connection:

Types of motor lines chokes		
	TVD6-200bl	TVD6.2-400bl
5A	-	MDD 1.6b-10
10A	MD78-10	MDD 1.6b-10
16A	MD84-20	MDD 2 b-20
25A	MD84-30	MDD 2.5b-30

Motor conductor l = 1.5m, 4-core, shielded.

Shield must be connected to the mounting plate on the device side as well as to the ground on the motor side.

Connection of the control conductors:

control conductors must be shielded, 1.5m. Shield must be connected to the ground.

Attention:

The order of the connections to the connector numbers or screw terminals is obligatory. All further advice is non-obligatory.

The input and output conductors may be altered or supplemented in accordance with the electrical standards.

Note:

- connection and operating instructions
- local regulations
- EU guideline 89/392/EWG
- VDE and TÜV regulations and Trade body guidelines



Input filter:

rf. to the CE advice, page 16

Short conductor length to be used between the input filter and the device or a shielded conductor to be used.

FI switch:

- layout acc. to the DIN standard VDE 0664
- release current >200mA
- only in combination with further protection measures

TVD-200bl

Connection to the 230V~ mains

AC voltage connection 1 x 230V~, 50/60Hz

Compact device up to 10A

Multiple axes combination up to 20A

Three-phase voltage connection 3 x 230V~, 50/60Hz

for >10A the multiple axes rack 20A is required

TVD.2-400bl

Connection to the 400V~ mains (T-NC mains power supply system)

for asymmetrical or unearthed power supply systems the connection must only be effected via an isolating transformer

AC voltage connection 1 x 400V~, 50/60Hz

Compact device up to 10A

Multiple axes combination up to 20A

Three-phase voltage connection 3 x 400V~, 50/60Hz

for >10A the multiple axes rack 20A is required

Dimensioning	10A	16A	25A	max. 30A
Conductor cross-section mm ²	0.75	1.5	2.5	2.5
Fuses - safety fuse Aff	10	16	25	30
Fuses - automatic cut-out (release feature A, acc. to EN60898)	10	16	25	25

Input fuses >>> semi-conductor fuses or semi-conductor automatic cut-outs



3 Electrical Installation

Connection with a transformer

- AC or three-phase voltage connection
- Auto-transformer or isolating transformer
(additional over-voltage protection provided)
- One transformer for multiple devices

Note:

- The relay contacts must be rated according to the transformer switch-on current.
- Slow fuses must be installed at the input of the transformer
- The fuses must be rated according to the transformer current
- Quick fuses must be used at the output of the transformer
- The fuse value for each mains module is max. 30AF

Transformer power: examples	
TVD6-200bl	TVD6.2-400bl
<p>Autotransformer Transformer rated power [VA]= $0.6 \times 230 \times IM \times GLF \times nF$</p> <p>Isolating transformer Transformer rated power [VA]= $1.42 \times 230 \times IM \times GLF \times nF$</p>	<p>Autotransformer Transformer rated power [VA]= $0.2 \times 400 \times IM \times GLF \times nF$</p> <p>Isolating transformer Transformer rated power [VA]= $1.25 \times 400 \times IM \times GLF \times nF$</p>
<p>IM = Sum of the motor currents (effective) GLF = simultaenity factor nF = speed ratio factor</p>	

GLF =

- 1 with 1 motor
- 0.5 ... 0.7 with 2 motors
- 0.4 ... 0.6 with > 2 motors

nF =

- effective speed
- maximum speed

ac voltage

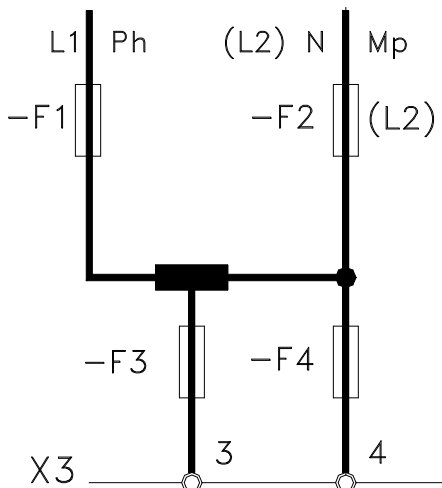

three-phase voltage

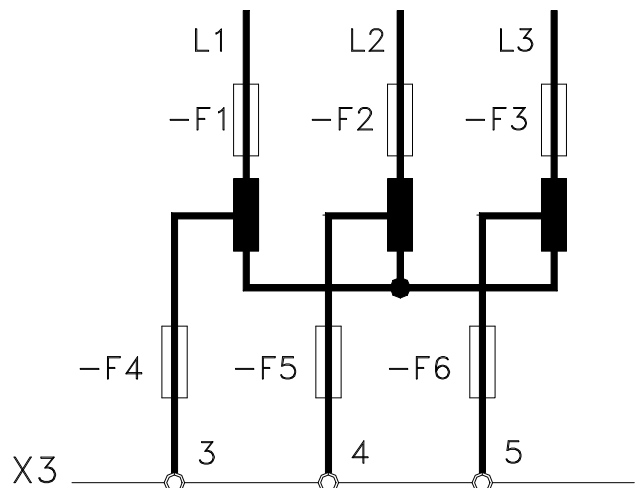

Note:

For power supply systems without protective conductors the connection must only be effected via an isolating transformer!!!

Connection to the TT mains

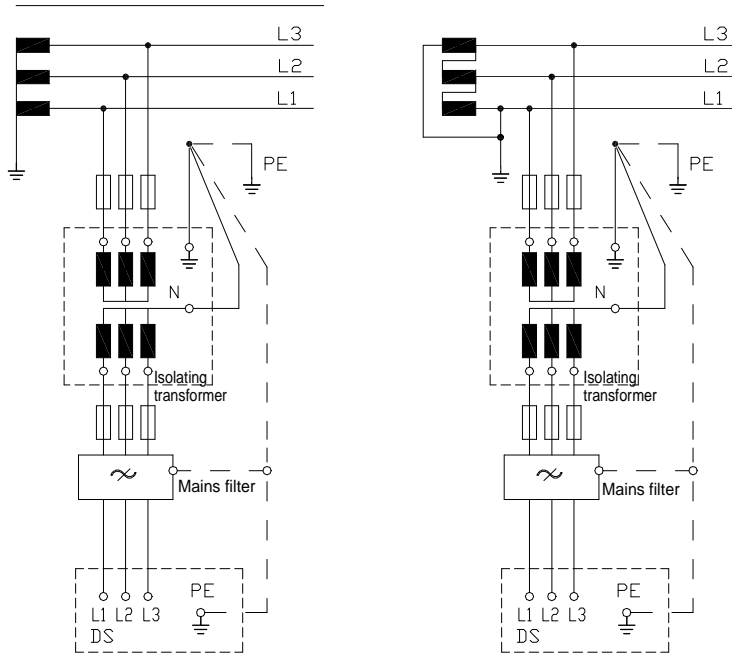

TT mains:

Symmetrical three or four conductor three-phase mains with direct earthing.

Device PE via the earthing connection.

Connection to the IT mains

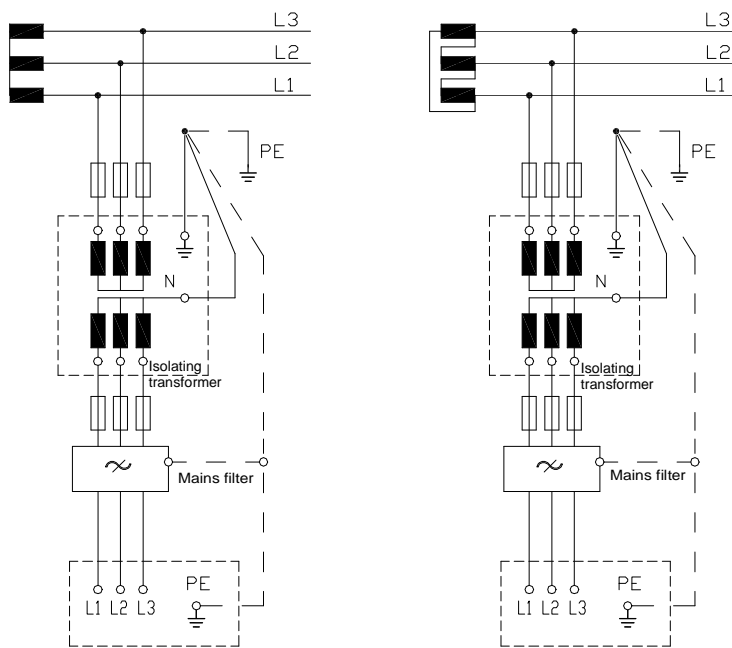

IT mains:

Symmetrical three or four conductor three-phase mains without direct earthing.

Device PE via the earthing connection.

Attention:

If the TVD6-Servo is directly connected and the transformer primarily switched, it is necessary to connect an additional over-voltage protection device (e.g. TRABTECH).

3 Electrical Installation

Motor power connection

Cable no.	PE	M1	M2	M3
Connection X3	X3:6	X3:7	X3:8	X3:9
Terminal X3:6 is internally connected to the PE connection bolt of the device				

Motor cable for	5A	10A	16A	25A	Thermo	Brake
Cross-section	0.75	1.5	1.5	2.5	0.75	0.75
Cable type	3 x shielded motor conductor + PE (+ if required: 2 x thermo + 2 x brake)					

Shielding

- with earth clamp
- directly to be connected to the switch cabinet input and to the motor
- multiple earthing in case of long conductor cables

Magnetic cores

- against HF failures

Motor chokes

- against LF failures
- against high leakage currents
- for motor efficiency
- for motor life

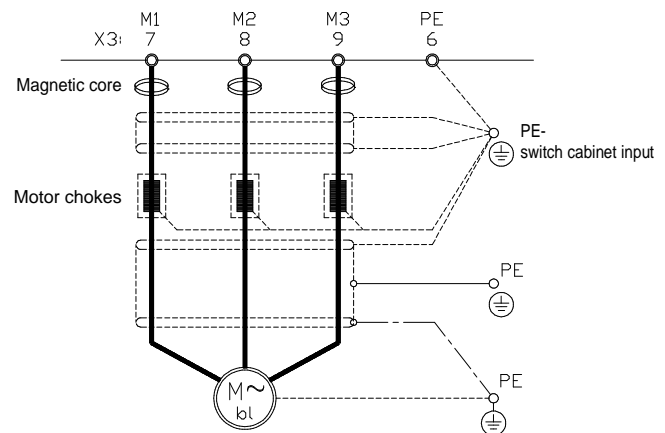

External ballast resistance

Dimensioning:

Mean value of the braking power per axis

$$P_{\text{Ballast}} [\text{W}] = \frac{1 \times J_g \times n^2}{2} - \frac{J_g^2 \times a \times n}{M_M} \times f$$

- J_g = reduced motor and load moment [kgm²]
- n = max. speed [s⁻¹]
- M_M = max. motor torque [Nm]
- a = delay time [s²]
- f = repetition frequency of the braking [s⁻¹]

Modify on the rear panel of the mains module:		
Remove soldered bridge D		
	TVD6-200bl	TVD6.2-400bl
External ballast resistor	smallest resistance value 22Ω	smallest resistance value 40Ω
Installed ballast resistor	20Ω/ 50W, for 3%d.cyc. = 1.5 kW	42Ω/ 50W, for 3%d.cyc. = 1.5 kW

The connection advice is a general information and it is non-obligatory.

Adhere to:

- connection and operating instructions
- local regulations
- EU guideline 89/392/EWG
- VDE and TÜV regulations and Trade body guidelines



Connection no. of the terminal connectors

X1:1 to X1:16 and X2:17 to X2:32

Signal conductors

Shielded and separated from power conductors, command value pairs twisted and shielded.

Logic connections

Relays with gold contacts or reed relays. Contact current 6mA.

Internal logic voltage 15V=

- Potential connection
- for relay control
- Jumpers J1 and J3 plugged-in

External logic voltage

- Potential isolation
- for PLC or CNC
- UEXT +15V to 30V= across terminal X2:27
- GNDE across terminal X1:11

- Jumpers J1 and J3 **not** plugged-in
- residual ripple of the logic voltage <20%

Basic set-up: Jumpers J1 and J3 are plugged-in.
Inputs and outputs via an optocoupler.

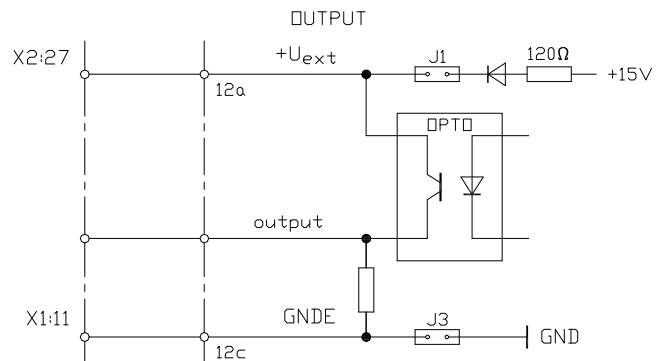
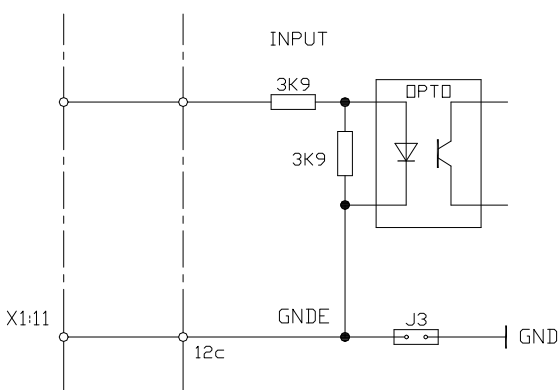

3 Electrical Installation

Drive enable >>> active with a positive voltage

- Jumper SW1 in position 2-3 (basic set-up)

Drive enable - internal logic voltage

- internal logic voltage X1:1 +15V/10mA
- contact circuit between X1:1 and X1:2

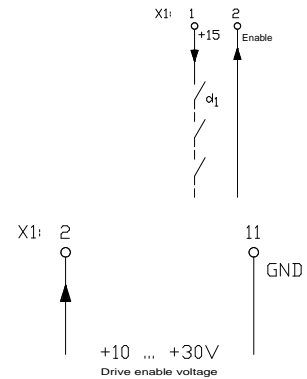

Drive enable - external logic voltage

- drive enable voltage +10 to +30V X1:2

Drive enable >> active at zero

- Jumper SW1 in position 1-2 (US version)

Drive enable - internal logic voltage

- logic zero X1:11
- contact circuit between X1:2 and X1:11

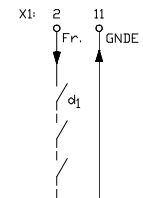

Drive enable - external logic voltage

- drive enable voltage 0V X1:2

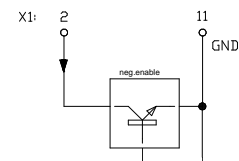

Drive enabled

- command value and speed control loop circuit are immediately active
- LED D1B bright

Drive disabled

Jumper **J2** plugged-in (emergency stop) (basic set-up)

- command value internally immediately to 0 (braking)
- LED D1B dark
- after 5 seconds >>> speed controller de-activated

Jumper **J2** open (decelerates without braking)

- speed controller is immediately de-activated
- LED D1BB dark

Note:

Jumper SW1

- Pos. 2-3 >>> Drive enable active at >+10V (basic set-up)
- Pos. 1-2 >>> Drive enable active at zero

Jumper J2

- plugged-in >>> emergency stop (basic set-up)
- open >>> deceleration without braking

Control connections

Output stage switch

Switch inputs

Drive enable for

- positive command value direction
LED 1D >>> contact between X2:27 and X1:16
- negative command value direction
LED 1H >>> contact between X2:27 and X2:32

Output stage switch - function	
Contact	Function
closed	Enable > LED bright
open	direction disabled
> output stage switch is connected >>> contact open - drive brakes > reversal of the command value direction - the drive is disconnected from the output stage switch - output stage switch disconnected >>> contact closed	

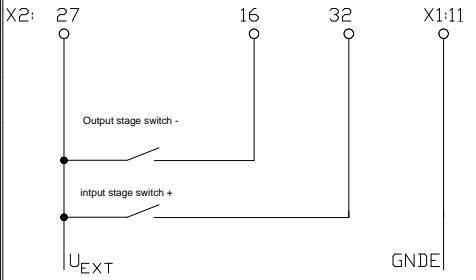

Attention:

without output stage switch >> connection between X2:27, X2:32, and X1:16

Integral switch-off function	
Function - Relay contact	
Contact	Speed control loop
open	P-I control
closed	P- control
Function - external logic voltage	
Voltage X2:31	Speed control loop
< 2V	P-I control

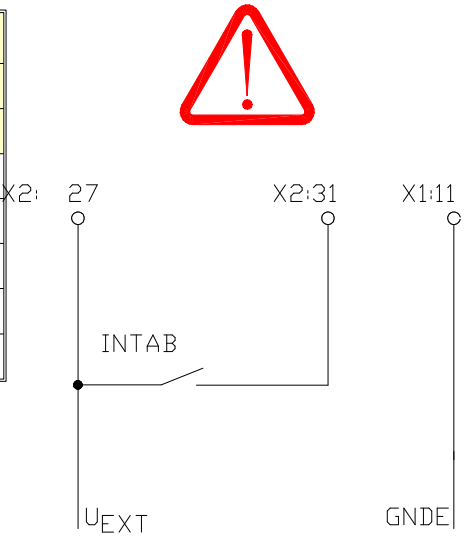

Note:

Please observe the optimisation advice

- Braking in case of a mains failure
- Braking function
- command value in case of a mains failure

Feed-back to the bus circuit



3 Electrical Installation

Speed command value

Voltage source for command values $\pm 10V$, 10mA

- +10V X1:3
- 10V X1:5
- GND X1:8

with internal voltage source >> Jumper S11, S12 plugged-in

Command value inputs

- Command value voltage max. $\pm 10V$ =
- Input resistance 50 k Ω
- Relay contacts: use gold or reed contacts

Command value pairs should be twisted and shielded.

The shield should be connected on one side.

Connections				
Command value	Connector	Jumper	Function	Measuring point
Command value 1	X1:4 (signal)		directly	X4:1
	X1:8 (GND)			X4:10
Command value 2	X2:17 (signal)	SW2 1-2 SW2 2-3	directly ramp	X4:2 X4:2
	X2:28 (GND)			X4:10

Jumper positions				
	Function	Jumper	Position	Basic set-up
Command value 1	Differential input	S12	open	
	with internal voltage source	S12	plugged	***
Command value 2	Differential input	S11	open	
	with internal voltage source	S11	plugged	***
	with ramp (integrator)	SW2	Pos. 2-3	***
	without ramp	SW3	Pos. 1-2	
without command value 2		SW2	open	

Resistors for a current command value of 0 to $\pm 20mA$

- Command value 1 R121 500 Ω
- Command value 2 R4 500 Ω

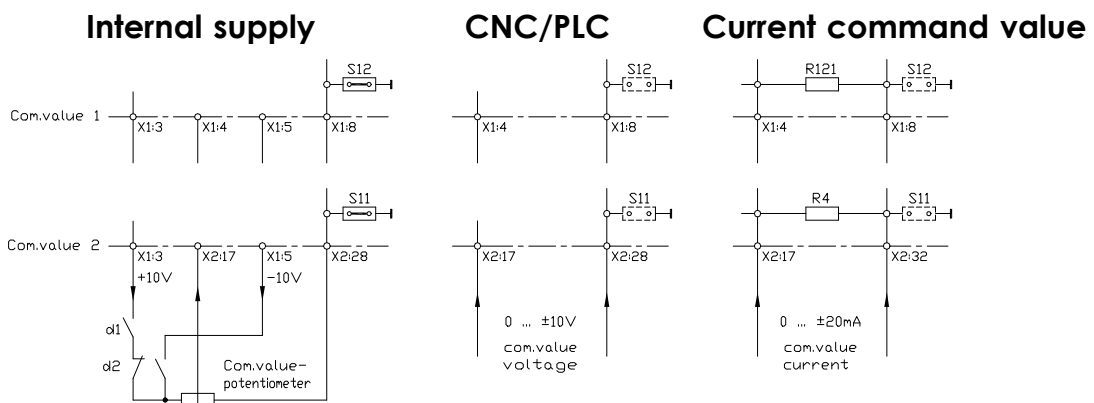

External current limiting

Voltage source for external current limits
+10V/10mA X1:3

Control range

0 ... + 5V >>> 0 to 100% rated current of the device
0 ... +10V >>> 0 to 200% rated current of the device

internal over-current watchdog >>> max. 5s

Inputs

Maximum input voltage +10V

Input resistance 10 kΩ

Internal reduction using the potentiometers I_{max1}, I_{max2}

Relay contacts: gold or reed contacts

Connections			
Current limit	Connector	Jumper	Measuring point
positive	X1:9 (signal)	S19 open	X4:3
	X1:7 (GND)		X4:10
negative	X1:10 (signal)	S20 open	X4:3
	X1:7 (GND)		X4:10

Internal supply

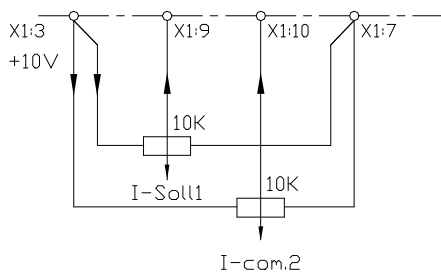

CNC/PLC

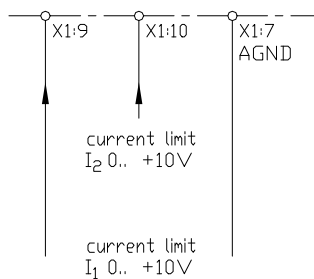

Current command value

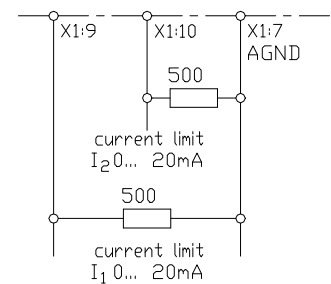

Attention:

If the current limit is internally adjusted >>> Jumper S19, S20 plugged-in.



Actual value connection

Connector X7

- 15-pin D-connector
- metallized plastic housing
- shield connected to the housing

Cable	up to 10m	12 x 0.14	shielded
	> 10m	12 x 0.25	shielded

Connections		
Function	Colour (recommended)	Pin no.
bl-tacho mp	grey	1
bl-tacho phase 1	yellow	2
bl-tacho phase 2	black	3
bl-tacho phase 3	white	4
GND	blue	6
+15V	violet	10
Thermo sensor	pink	6
Thermo sensor	orange	12
Rotor position 1	brown	13
Rotor position 2	green	14
Rotor position 3	red	15
Additional connections when using a dc tacho:		
-15V	grey	7
dc tacho signal	yellow	9
dc tacho GND	black	8
(The BL-tacho connections at pin no. 1 to 4 are removed)		
Pin no. 6 is double-coated. For motors without thermal sensor >>> bridge between pin no. 6 and 12		

Attention: It is absolutely necessary to observe the motor-specific connection data sheets (Appendix A).



Drive ready - BTB signal

Relay RL2

Signal contact

X2:21 - X2:22

Switch rating

max. 48V, 0.5A

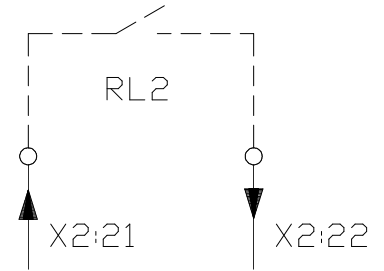

The BTB contact signals to the PLC/CNC that the drive is functional.
 The BTB signals of several axes can be connected in series.
 Delay time after switching on the power supply >> max. 1sec.

Display		
Drive ready	LED D1A bright	contact closed
Error	LED D1A dark	contact open
BTB contact drops in case of:		
Error	BTB LED D1A	LED display
Actual value error	dark	LED D2H bright
Over-temperature	dark	LED D2G bright
Short-circuit, short-circuit to earth	dark	LED D2F bright
Voltage error	dark	LED D2B bright
Bus error	dark	LED D2A bright

Attention:

In any case the BTB contact (drive ready) must always be used with the CNC/PLC!



Analog parameter measurement outputs		
Function	Motor current	Speed
Connector	X2:20 - X2:24	X1:6 - X1:7
Messwert	2.5V = type current	Tacho voltage
	5.0V = peak current	at the input of the divider
	unipolar positive	bipolar
output resistance	1 kΩ	4.7 kΩ

3 Electrical Installation

Output signals

Logic outputs with optocoupler

- wire-break proof
- output voltage 10 to 30V=
- output current 5mA
- output resistance 1kΩ

Output signals				
Signal	Function	Output	Display	saved
Bus	mains module error	X1:14	LED2A	yes
Overload	disable	X2:18	LED 1F	no
Stationary	speed < 1%	X2:25	LED 1E	no
Over-temperature	motor >150°C	X2:26	-	no
	heat sink >75°C	X2:26	-	no
	heat sink >80°C	X2:26	LED 2G	yes
Pre-warning	motor, heat sink too hot	X2:19	-	no
Reference ground	GND	X2:23	-	-

Memory deletion

- Drive enable off/on Jumper S6 plugged-in (basic set-up)
- Mains off/on Jumper S6 off

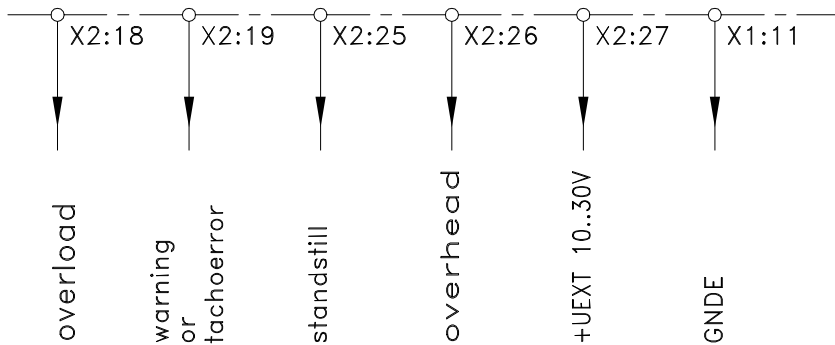

Control connections X1, X2

Function	Terminal no.	Connector no.
	(internal)	
+ 15 Volt (for enable)	X1: 1	X11: 32c
Enable input(+10 to +30 Volt)	X1: 2	X11: 30c
+ 10 Volt (for command value)	X1: 3	X11: 28c
Command value 1 - input (signal)	X1: 4	X11: 26c
- 10 Volt (for command value)	X1: 5	X11: 24c
DC tacho input (signal)	X1: 6	X11: 22c
DC tacho input (AGND)	X1: 7	X11: 20c
Command value 1 - input (AGND)	X1: 8	X11: 18c
Current limit I1 external	X1: 9	X11: 16c
Current limit I2 external	X1: 10	X11: 14c
external GNDE	X1: 11	X11: 12c
-15V (external electronics)	X1: 12	X11: 10c
Device zero GND	X1: 13	X11: 8c
Bus error	X1: 14	X11: 6c
Amplification 1:1	X1: 15	X11: 4c
Output stage switch -	X1: 16	X11: 2c
Command value 2 - input (signal)	X2: 17	X11: 32a
Overload signal	X2: 18	X11: 30a
Temperature signal without tacho fault	X2: 19	X11: 28a
Current (I_{act})	X2: 20	X11: 26a
Drive ready BTB	X2: 21	X11: 24a
Drive ready BTB	X2: 22	X11: 22a
Device zero GND (ground)	X2: 23	X11: 20a
analog device zero (AGND)	X2: 24	X11: 18a
Stationary signal	X2: 25	X11: 16a
Over-temperature	X2: 26	X11: 14a
external voltage UEXT	X2: 27	X11: 12a
Command value 2 input (AGND)	X2: 28	X11: 10a
Current command value	X2: 29	X11: 8a
+15V (external electronics)	X2: 30	X11: 6a
Integral term disable	X2: 31	X11: 4a
Output stage switch +	X2: 32	X11: 2a

3 Electrical Installation

Power connections X3

Function	Terminal no.	Connector no.
Bus external ballast resistor	X3: 1	X31: 18, 20 abc
Bus +	X3: 2	X31: 14, 16 abc
Mains L1 TVD6-200/230V~ TVD6.2-400/400V~	X3: 3	X31: 10, 12 abc
Mains L2 TVD6-200/230V~ TVD6.2-400/400V~	X3: 4	X31: 6, 8 abc
Mains L3 TVD6-200/230V~ TVD6.2-400/400V~	X3: 5	X31: 2, 4 abc
PE	X3: 6	
Motor 1	X3: 7	X31: 22, 24 abc
Motor 2	X3: 8	X31: 26, 28 abc
Motor 3	X3: 9	X31: 30, 32 abc

Encoder connector X7

Function	D-connector no.	Connector no.
bl-tacho mp	X7: 1	X11: 2b
bl-tacho phase 1	X7: 2	X11: 6b
bl-tacho phase 2	X7: 3	X11: 10b
bl-tacho phase 3	X7: 4	X11: 14b
free	X7: 5	
GND	X7: 6	X11: 22b
-15V	X7: 7	X11: 26b
DC tacho -	X7: 8	X11: 20c
DC tacho +	X7: 9	X11: 22c
+15V	X7: 10	X11: 24b
free	X7: 11	
Temperature sensor	X7: 12	X11: 16b
Rotor position 1	X7: 13	X11: 12b
Rotor position 2	X7: 14	X11: 8b
Rotor position 3	X7: 15	X11: 4b

Test point connector, connection to the optional units X4

Function	Connector no.
1 st n-command value at the output of the diff. amplifier	X4: 1
2 nd n-command value at the output of the diff. amplifier or integrator	X4: 2
I-command value	X4: 3
+ 10 V	X4: 4
- 10 V	X4: 5
I-actual value	X4: 6
n-actual value (at the output of the divider)	X4: 7
Enable	X4: 8
Device ground GND	X4: 9, 10

Transistor Servo-Drive TVD6-200bl, TVD6.2-400bl

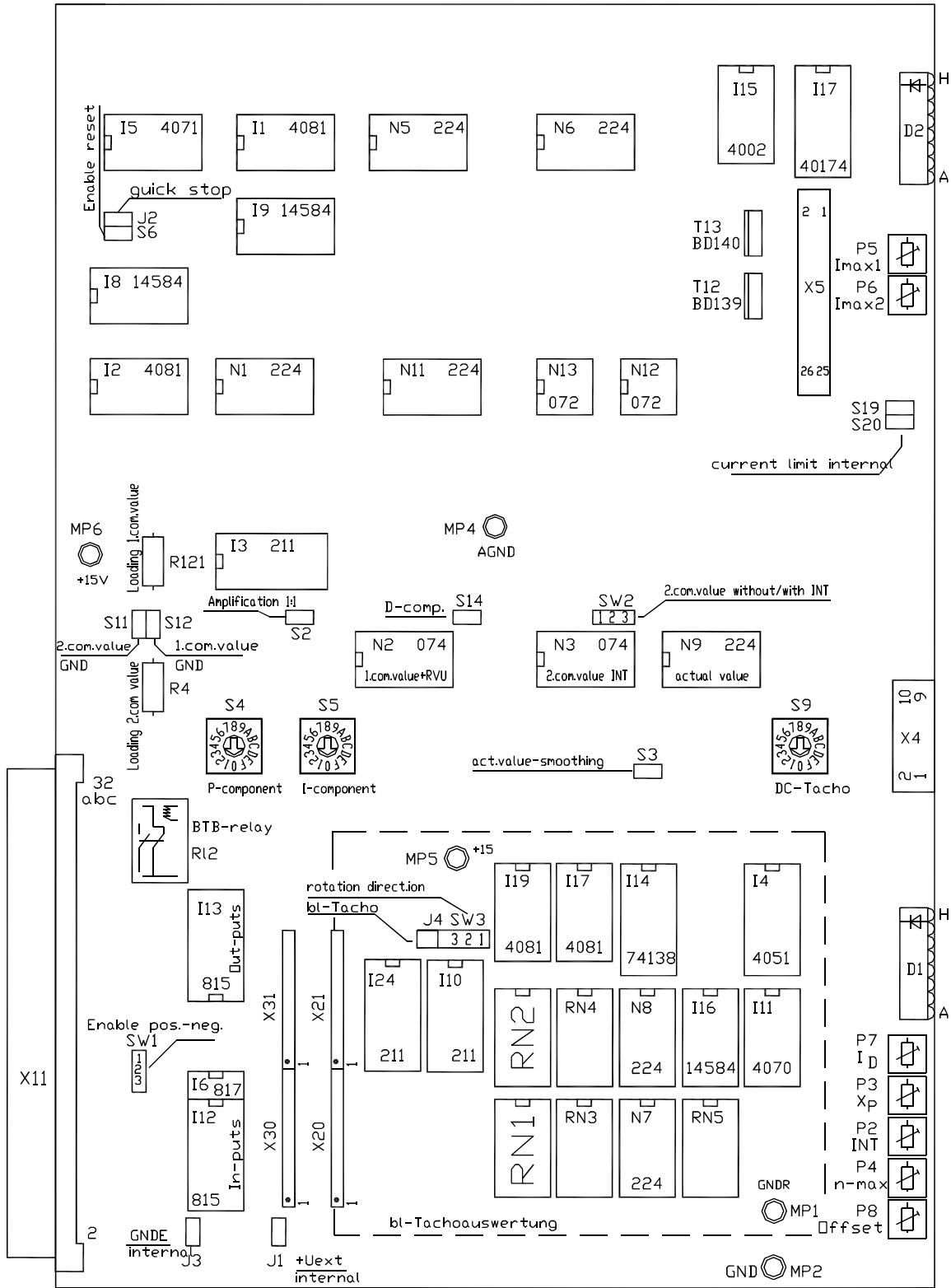

4 Device Overview

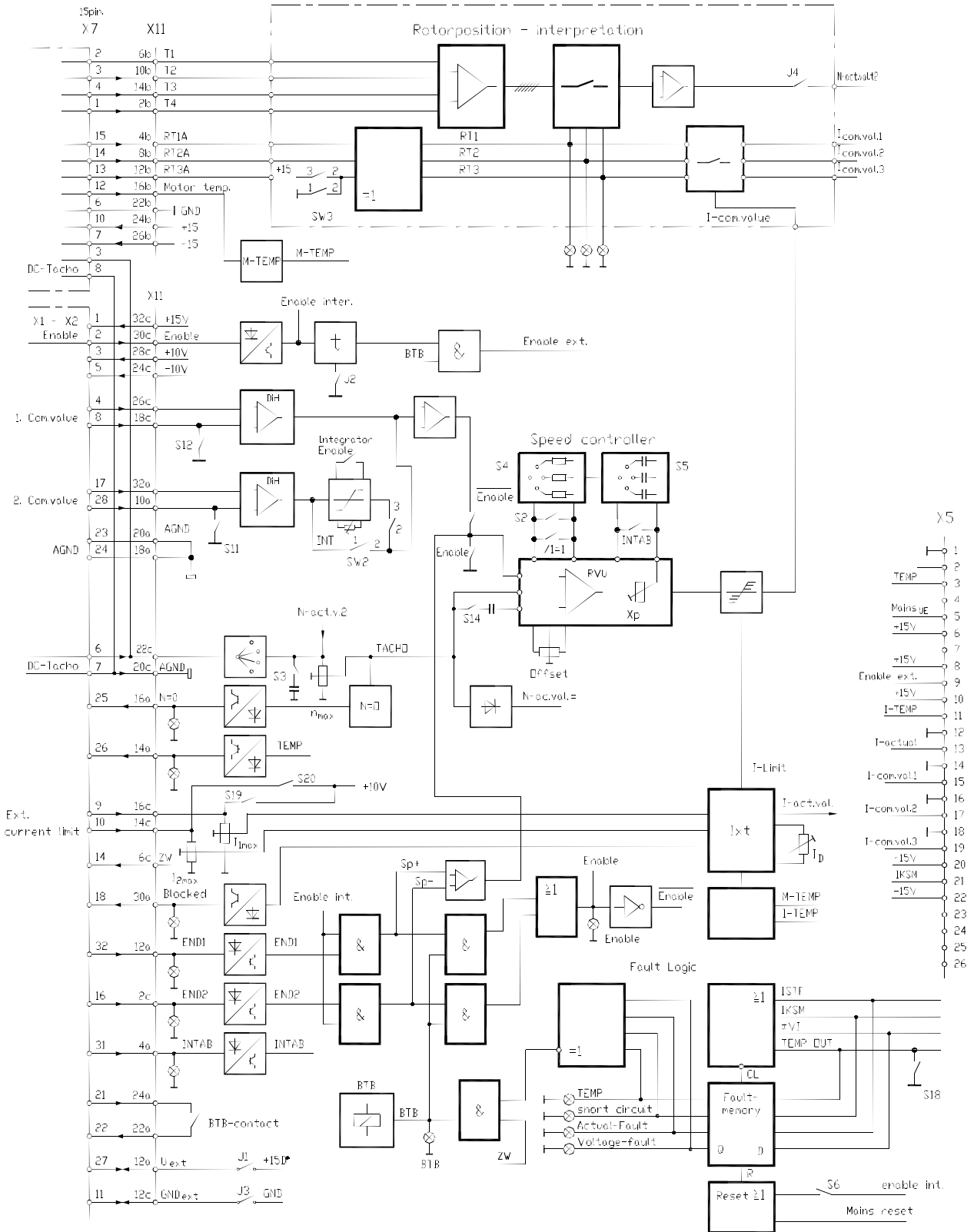

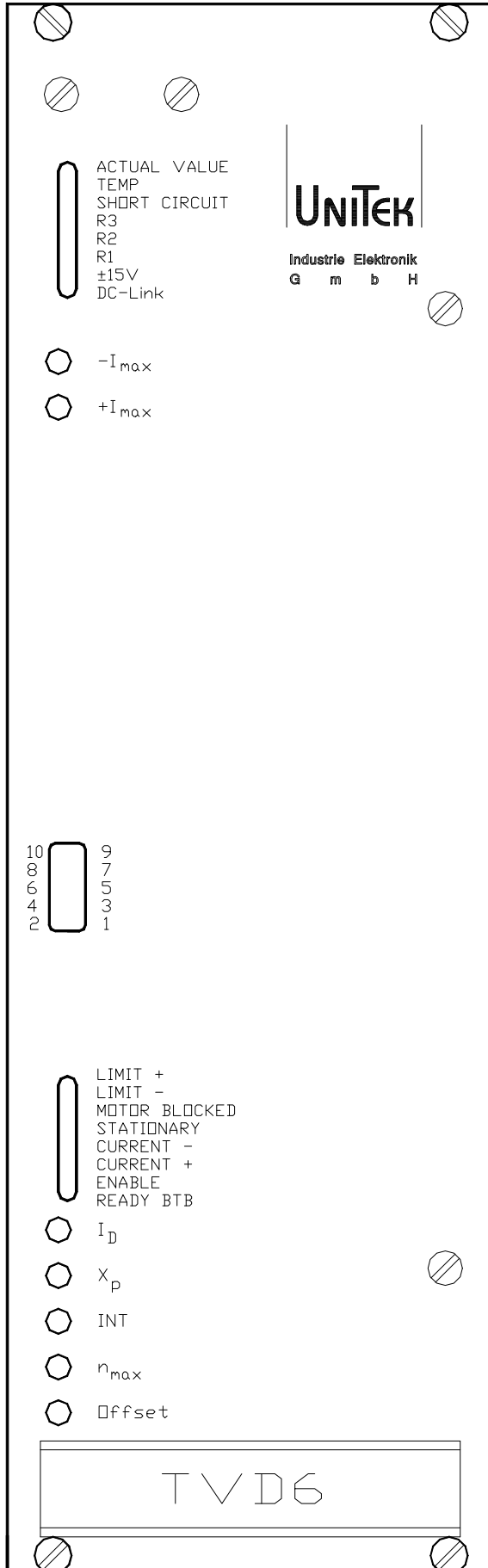

LED displays 2x

- Actual value error
- Temperature error
- Short-circuit
- Rotor position 3
- Rotor position 2
- Rotor position 1
- Voltage error
- Bus error

Adjustment potentiometers

- Current limit I_{max} -
- Current limit I_{max} +

Test point connector X4

- 1 1st command value at the output of the differential amplifier
- 2 2nd command value at the output of the integrator
- 3 Current command value
- 4 +10V
- 5 -10V
- 6 Current actual value
- 7 Speed actual value
- 8 Enable
- 9 free
- 10 Device zero GND

LED displays 1x

- Output stage switch +
- Output stage switch -
- Overload - disabled
- Stationary
- Current direction -
- Current direction +
- Enable
- Drive ready BTB

Adjustment potentiometers

- I_D Continuous current limit
- X_P Amplification
- INT Integrator time
- n_{max} Speed
- Offset zero point

Adjustments

Function	Component
Actual value adjustment bl-tacho	Poti P4 (n_{max})
Actual value adjustment, option dc tacho	Binary switch S9 + Poti P4
Internal current limit	Jumper S19, S20 Poti P5 (I_{max1}), S19 Poti P6 (I_{max2}), S20
External current limit	Poti P5 (I_{max1}) Poti P5 (I_{max2})
Continuous current	Poti P7 (I_D)
Integrator	Jumper SW2 (2-3) Poti P2 (INT)
Amplification P-term	Binary switch S4 Poti P3 (X_P)
Amplification I-term	Binary switch S5
Offset	Poti P8

Plug-in jumpers

Function	Jumper no.
1 st command value input, ref. zero	S12
2 nd command value input, ref. zero	S11
Ramps 2 nd command value on/off	SW2 2-3/1-2
Actual value differentiation	S14
Actual value smoothing	S3
Current limit 2, internal	S19
Current limit 1, internal	S20
Amplification 1=1	S2
ext. +UL = int. +15V	J1
ext. GND = int. GND	J3
Emergency stop (delay - blocked control loop)	J2
Actual value bl-tacho	J4
Enable - reset	S6
Enable - pos./neg. logic	SW1 2-3/1-2

LED signals

Function		LED no.
Control electronics		LED D1x
Output stage switch +		LED H
Output stage switch -		LED G
Disabled		LED F
Stationary		LED E
Speed loop output -		LED D
Speed loop output +		LED C
Command value enable		LED B
Drive ready BTB		LED A
Power section		LED D2x
Actual value error	saved	LED H
Temperature	optional	LED G
Short-circuit	saved	LED F
Rotor position 3		LED E
Rotor position 2		LED D
Rotor position 1		LED C
Voltage error	saved	LED B
Bus error	not saved	LED A

5 Adjustment

Adjustments

- to be carried out only by qualified personnel
- Observe all safety regulations
- Follow the correct adjustment sequence



Pre-setting

Actual value	>>> jumper
Command value inputs	>>> jumper, differential input
logic inputs/outputs	>>> jumper, internal/external supply
P-I parameter switch	>>> jumper, switch

Optimisation

Current controller	adjusted in the factory (P or PI control loop)
Actual value adjustment	nmax adjustment
Current limits	Imax, ID adjustment
Speed controller	P-I switch, Xp adjustment
Slope limiting device (integrator)	INT adjustment (only command value 2)
Zero point	Offset adjustment
Path/position controller	in the CNC\PLC control



Attention:

Always optimise beginning with the innermost control loop and work out.

Sequence: current controller>speed controller>position controller (CNC\PLC)

Test points

Test point connector X4

Measurement

	max. value	Connector
Command value 1 at the output of the input amplifier	±10V	X4:1
Command value 2 at the output of the input amplifier	±10V	X4:2
Current command value (control function speed controller)	±10V	X4:3
Current actual value, unipolar	±5V	X4:6
Speed actual value at the output of the divider	±5V	X4:7

Command Value

Function		Command value1	Command value2
Input amplification	fixed	1	1
Input voltage	max.	±10V=	±10V=
Differential input	jumper	S12 open	S11 open
Input referred to GND	jumper	S12 plugged-in	S11 plugged-in
Input signal		X1:4	X2:17
Input GND		X1:8	X2:28
Test point connector		X4:1	X4:2
Measured value	max.	±10V=	±10V=
Integrator function		not existing	jumper SW2

Input referred to GND	Differential input
for a potentiometer command value	for a command value from the PLC/CNC
with internal voltage supply	external command value
Jumper S11, S12 plugged-in	Jumper S11, S12 open
Check the GND connection	The signal and GND connections can be swapped. (Basic set-up)

Both command values connected:

- The command values 1 and 2 are added internally.
- Check the signs.
- The sum of the command values must not be superior to ±10V.

Only with the command value 2			
- acceleration and braking ramp - linear integrator			
Command value 2	Jumper	Poti	Range
without integrator	SW2 Pos. 1-2	—	—
with integrator	SW2 Pos. 2-3	INT(P2)	0.1 to 4.5 sec.
without command value 2	SW2 open	—	—

Command value current

Command value from an external current source 0 to ±20mA.
Internal load resistors for 0 to max. ±10V.

Command value 1 Resistor R121
Command value 2 Resistor R4

Resistance values [Ω] = command value voltage/command value current
(max. 500 Ω)

Attention:

Do not use the command value current of 4 to 20mA.



5 Adjustment

Speed actual value

Attention: Observe in any case the motor-specific connection data sheets (see appendix A).



Actual value

Actual value bl-tacho with rotor position encoder

Connection test:

Motor turning anti-clockwise
(looking onto the rear side of the motor acc. to DIN)
There is only one correct connector configuration.

Rotor position encoder

LED signal sequence R1>R1+R2>R2>R2+R3>R3>R3+R1>R1>R1+R2 etc.

Tacho signal X4:7

>uniform speed-proportional voltage, no saw-tooth voltage

Pre-settings with the resistance network RN1, RN2

- Resistance value (Ohm) = tacho voltage x max. speed
- Basic set-up for 3000 min⁻¹
- for further max. speeds: pls indicate on order

Fine adjustment with potentiometer n_{max} (P4)

Command value from the potentiometer:

- with a 1V command value: adjust the speed to 10% of the maximum required
- with a 10V command value: make fine adjustment to achieve 100% (max speed)

Command value from a CNC/PLC:

- with a 0.8V command value: adjust the speed to 10% of the maximum required

Sense of rotation (seen on the rear panel of the motor, DIN)			
Command value	Sense of rotation	Jumper	Position
positive	clockwise	SW3	Pos. 1-2
positive	anti-clockwise	SW3	Pos. 2-3

Option dc tacho for motors with dc tacho or rotor position encoder

- fine adjustment see 'bl-tacho'

Switch S9											
Rough tach adjustment											
Stellung	0	1	2	3	4	5	6	7	8	9 bis F	n _{max}
Tacho-Spannung	∞	67	40	32	25	23	20	18	14	12V	min.
		100	70	50	40	35	30	25	18		mean
		205	145	97	85	70	65	55	35		max.

Current limiting

Peak current	range 0 to 200% rated current maximum reset time 5sec.	Poti P5/P6
Continuous current	range 5 to 100% rated current	Poti P7

Internally resetting current limits		
Current limit	Function	Limit
Overload	Time	Continuous current
Heat sink	Temperature	50% rated current
Motor	Temperature	50% rated current
The lowest current limit is effective!		

Peak current

Internal current limit (Basic set-up)		
Adjustment	Jumper	Potentiometer
I _{max1}	S19 plugged-in	I _{max1} (P5)
I _{max2}	S20 plugged-in	I _{max2} (P6)

External current limit			
Adjustment	Input	Jumper	Potentiometer
I _{max1}	X1:9 0 to +10V	S19 open	I _{max1} (P5)
I _{max2}	X1:10 0 to +10V	S20 open	I _{max1} (P6)
The external current limiting voltage can be reduced internally by means of the potentiometer I _{max} .			

Continuous current

The motor protection for both torque directions is adjusted to motor rated current by means of the potentiometer I_D (P6)

Measuring adjusted values:

- Do not connect the motor
- Preset the command value and enable > switch on/off
- The value to be measured applies across the test point connector X4:3 (5V=rated current)

Command value	Measured value I (2 sec.)	Measured value I _D
+ 5V	0 to max.10V	0.25 to max. 5V
- 5V	0 to max.10V	0.25 to max. 5V

Current actual values

Measured value at the test point connector X4:6 >>> I_{max} = 0 to +5V
I_D = 0.12 to +2.5V

Note: for an exact torque control:

- the device is adjusted to from P- to PI-control in the factory
- please indicate on order



5 Adjustment

Speed control loop circuit

- two 16-position binary switches S4, S5
- amplification potentiometer P3 (XP)
- D-term with jumper S14

Take over the adjusted values when the device is exchanged.

Basic set-up

- binary switches S4 and S5 in position 4
- amplification poti Xp to 50%
- no D-term, jumper S14 open
- suits the majority of drives

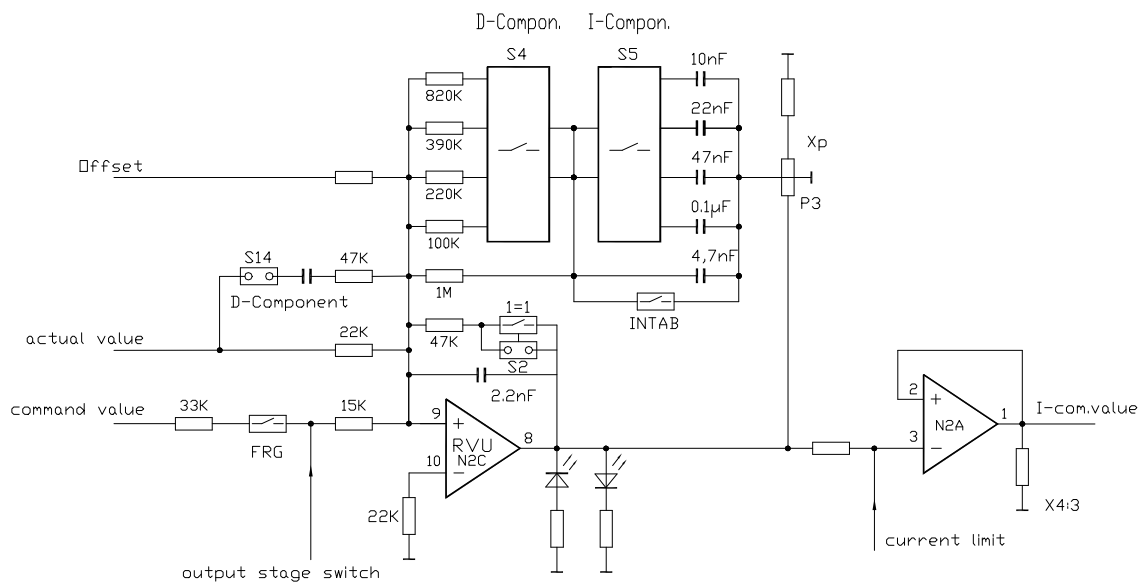

Adjustment of the proportional term by means of the binary switch S4

Switch S4								
Position	0	1	2	3	4	5	6	7
R-Value kΩ	1000	450	280	209	180	148	123	107
Position	8	9	A	B	C	D	E	F
R-Value kΩ	90	82	73	67	64	59	55	52

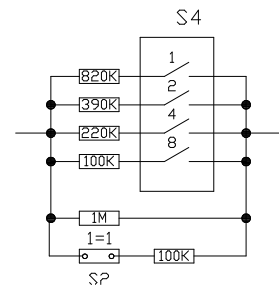

Adjustment of the proportional term by means of the binary switch S5

Switch S5								
Poition	0	1	2	3	4	5	6	7
C-Value µF	0,01	0,02	0,03	0,04	0,08	0,09	0,1	0,11
Position	8	9	A	B	C	D	E	F
C-Value µF	0,11	0,12	0,13	0,14	0,18	0,19	0,2	0,21

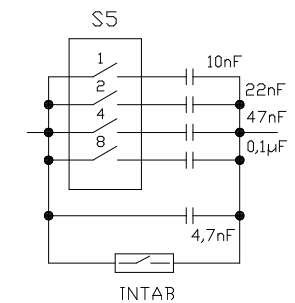

Note:

The integral term can be switched off through the use of the input INTAB (X2:31)

Proportional amplification

Function binary switch S4

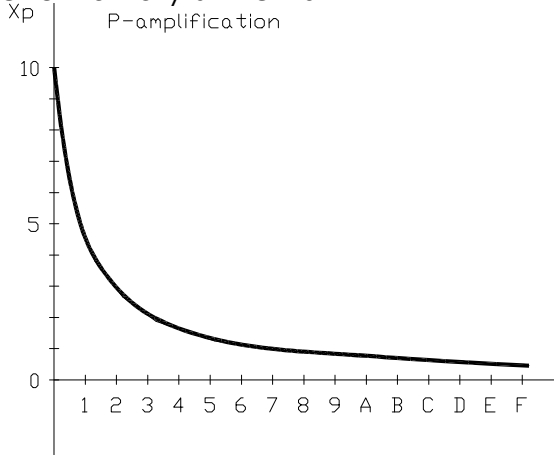

Function potentiometer Xp

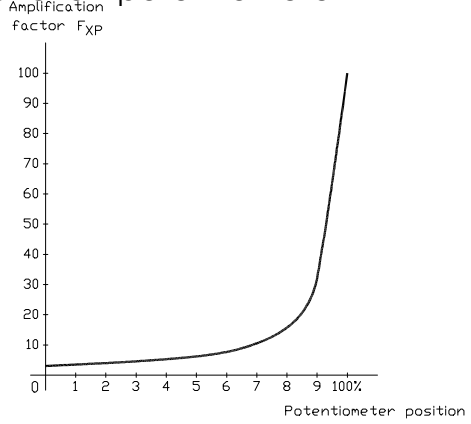

Proportional amplification = $X_P \times F_{XP}$

Adjustment by means of an oscilloscope

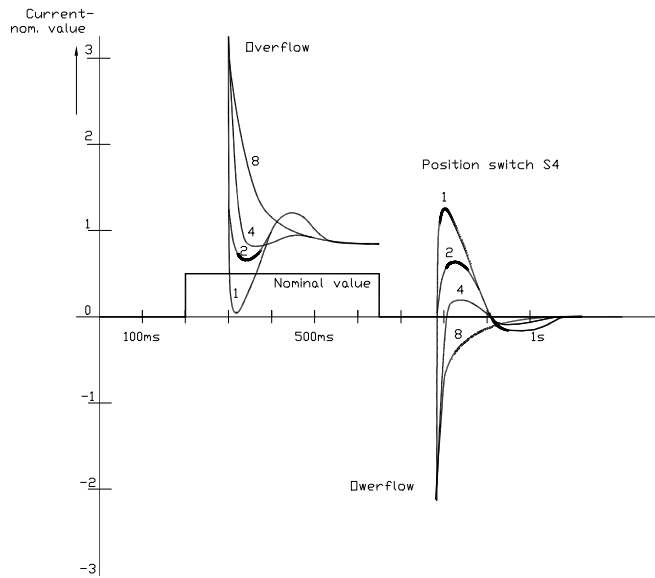

Adjustment

- Command value jump $\pm 0.5V$
- Input INTAB X2:31 activated

Measured value

Command value	X4:1
Controller response	
Current command value	X4:3

Effect D-term

- Actual value differentiation
- Jumper S14 plugged-in

Attention:

Do **not** use the D-term for the position control (CNC/PLC)!

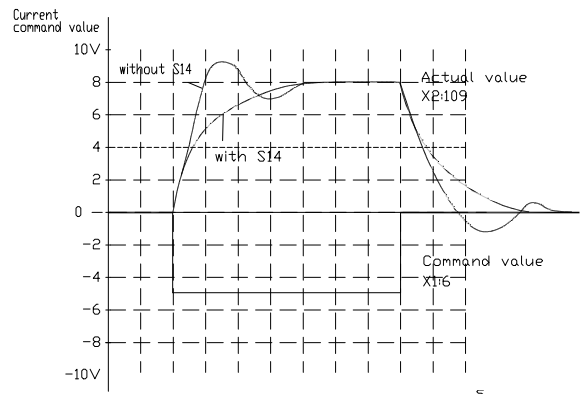

5 Adjustment

Adjustment without measurement equipment

Connect the motor,

command value = 0

XP = 50%

switch S4 = position 4

switch S5 = position 4

enable the drive,

turn the potentiometer XP clockwise until the axis begins to oscillate.

If the axis does not oscillate

- reset the switch S4 to a lower value.
- Adjust by means of the potentiometer XP until the oscillations begin.
- Turn the potentiometer XP anticlockwise until the oscillation disappears.
- Turn poti XP back another 2 clicks.

Adjust the switch S5 in such a way, that when a command value jump of 50 % occurs, the drive runs smoothly after approx. two oscillations.

Drive behaviour:	
Amplification too low	Amplification too high
Large overshoots	vibrates > during acceleration
Overshoots destination position	vibrates > during braking and in position

Attention:

Drives connected to CNC\PLC controllers:

for the maximum speed output from the controller, adjust the speed command value to between 8 and 9V.



Standard set-up

Before commissioning check the following connections

- Nominal power supply terminals no. X3:3, X3:4, X3:5
max. 230V~ (TVD6-200)
max. 460V~ (TVD6.2-400)

- Protection earth earthing screw on the housing
- Motor connection terminals X3:7, X3:8, X3:9
- Motor earth connection terminal X3:6
- Option
- external ballast resistance terminals no. X3:1 and X3:2
- Fuse type, fuse value

(Please observe the connection advice, page 12)



Encoder connection X7 observe the motor-specific connection data sheets (see appendix A)

Power connections

- Protective earth
- Mains 1x or 3x 230V~ (for TVD6-200bl)
1x or 3x 400V~ (for TVD6.2-400bl)
- Motor 3 x motor conductors + protect. conductor + shield
- Encoder connection observe the motor-specific connection data sheets

Control connections

- Enable contact between X1:1 and X1:2
- Command value signal X1:4, GND X1:8
- Output stage switch output stage switch across X1:16 and X2:32
or bridge between X2:27 and X1:16, X2:32

Basic set-up for the first commissioning

Switch	S4	P amplification	position 4
Switch	S5	I-term	position 4
Potentiometer	I _{max1}	peak current	10%
Potentiometer	I _{max2}	peak current	10%
Potentiometer	I _D	continuous current	100%
Potentiometer	X _P	amplification	50%
Potentiometer	INT	integrator	left full scale
Potentiometer	n _{max}	speed	left full scale

Jumper	open	plugged-in
	S2, S14	J1, J2, J3, J4
		S3, S6, S11, S12, S19, S20
	SW1 pos. 1-2	SW1 pos. 2-3
	SW2 pos. 1-2	SW2 pos. 2-3

6 Commissioning

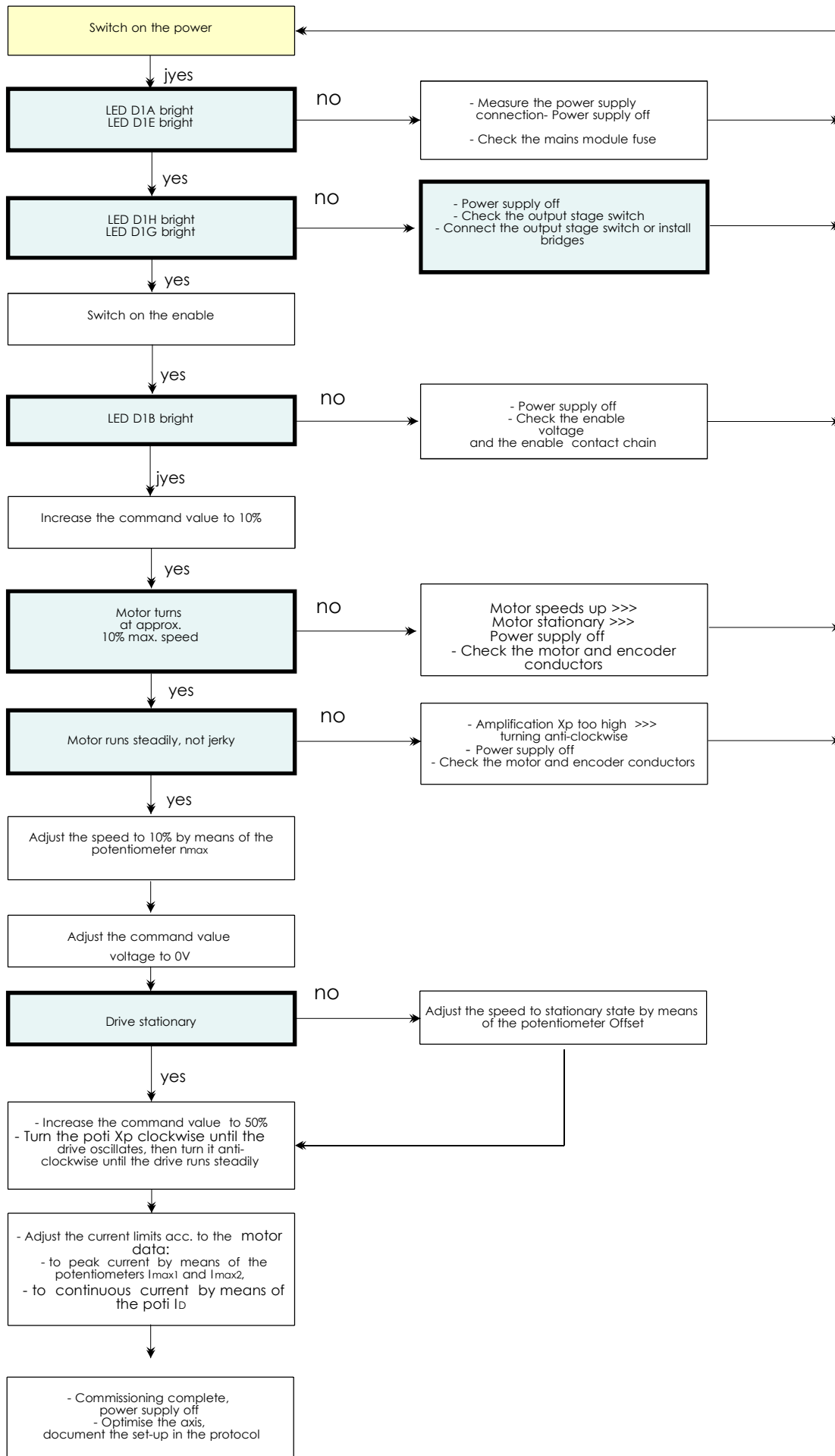

LED displays

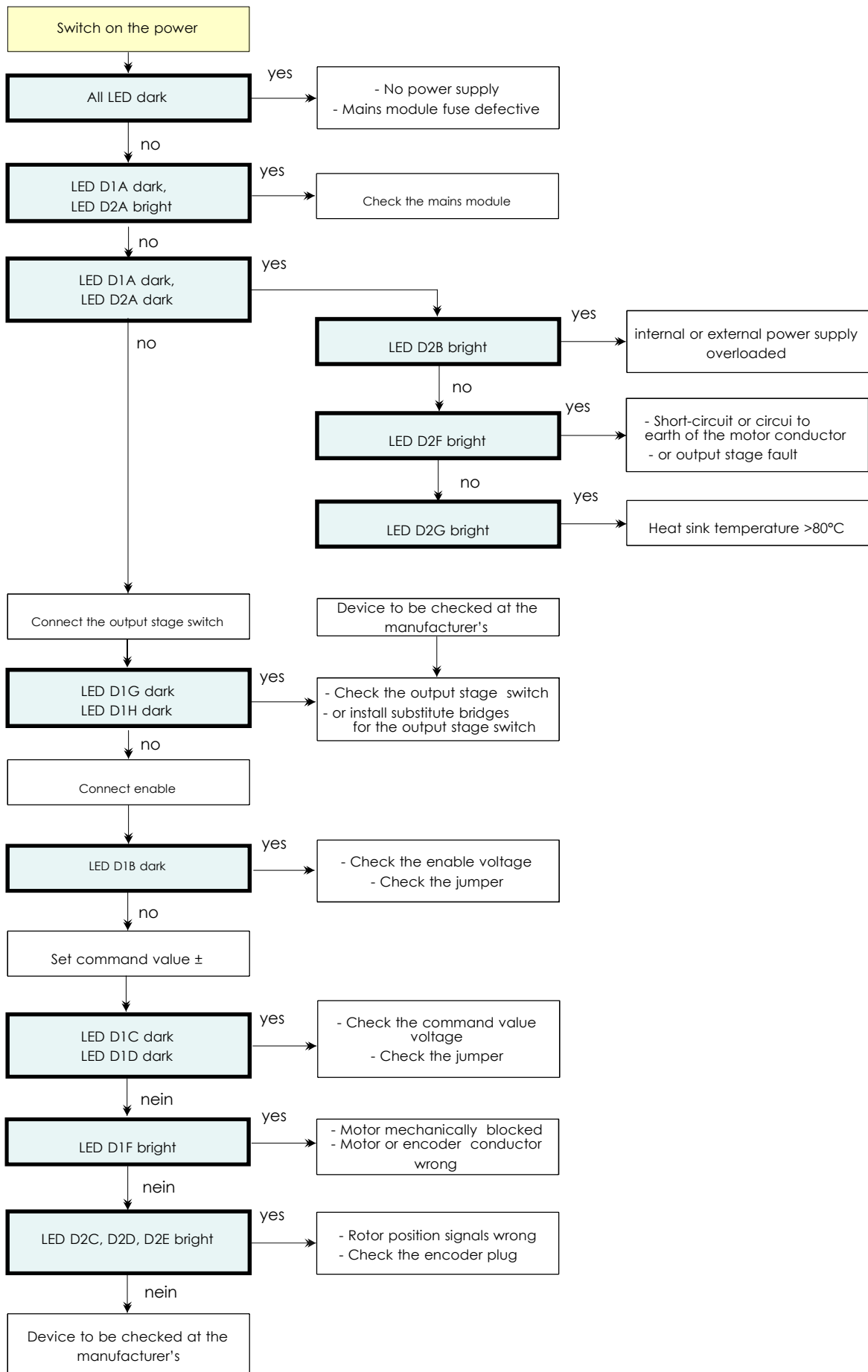

7 Faults Diagnosis

Fault diagnosis

Fault	Causes
Motor stands in one position, runs jerky or oscillates in one position	- Encoder or motor conductor cores mixed up or interrupted
Motor speeds up	- Motor or rotor position conductor cores leading or lagging by 120° in the rotating field
Motor runs unsteadily	- Tacho conductor cores mixed up or interrupted - Amplification too high - Command value faults
Mains module switches to failure during braking, LED D2A bright	- Braking energy too high
Mains module switches to failure when being switched on, LED D2A bright	- No connecting phase - or the power supply voltage is too low
Amplifier switches to failure	- Over-temperature - Phase short-circuit or short-circuit to earth - BTB fault - Output stage fault
Speed cannot be adjusted with poti n_{max}	- Resistance network RN1, RN2 wrong

Functional diagram - test point connector

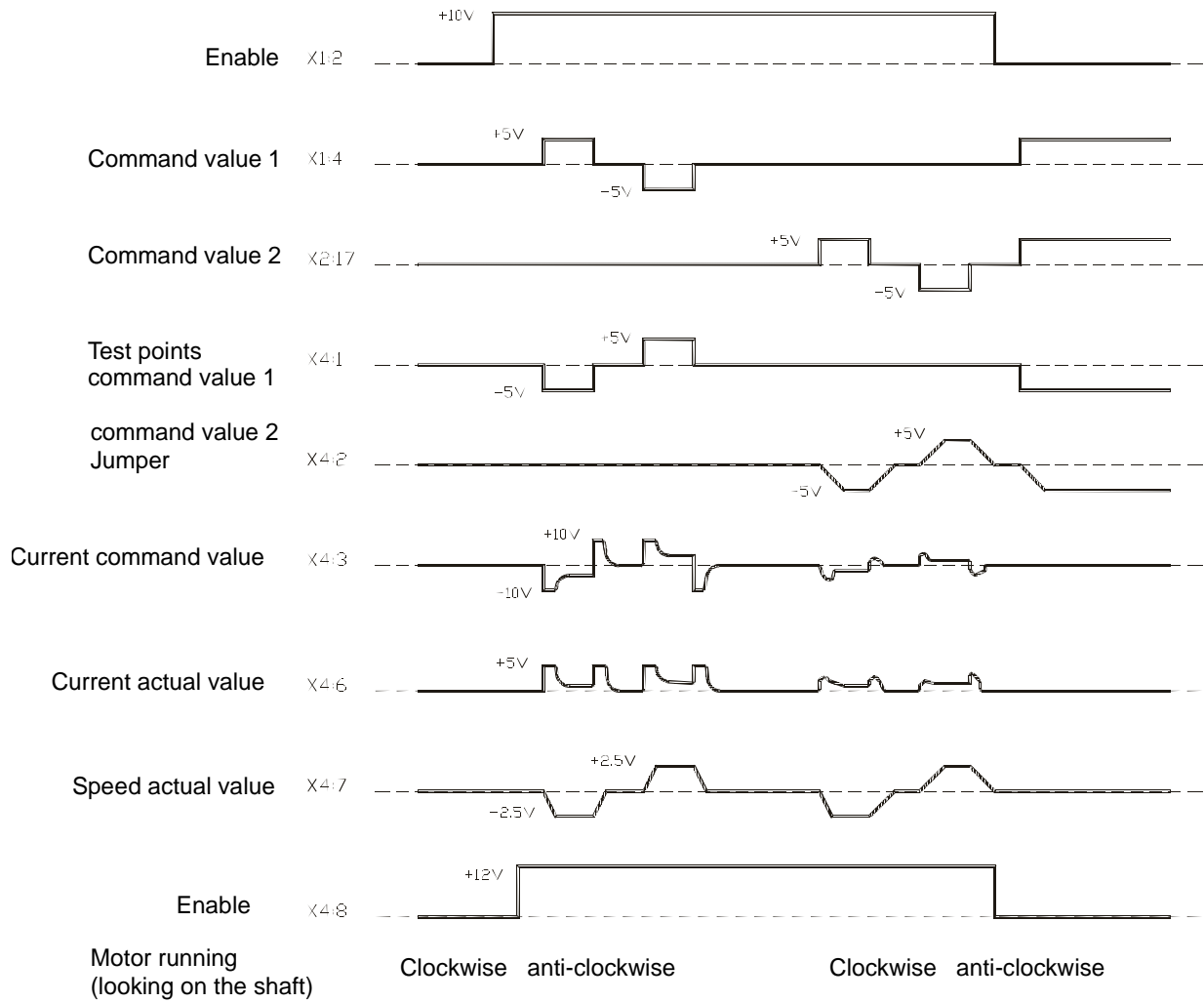

7 Faults Diagnosis

Functional diagram bl/ec motor amplifier
 Funktions-Diagramm bl/ec Motorverstärker

Rotor position encoder
 Rotorlagegeber

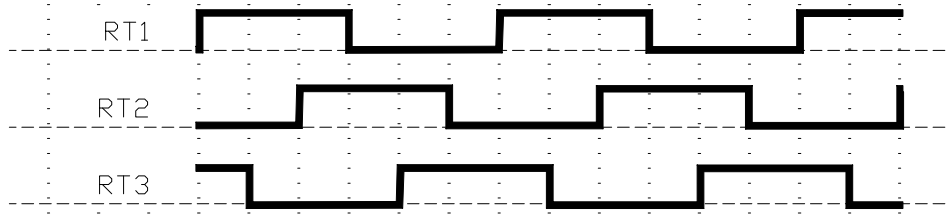

Tachometer voltage
 Tachospannung

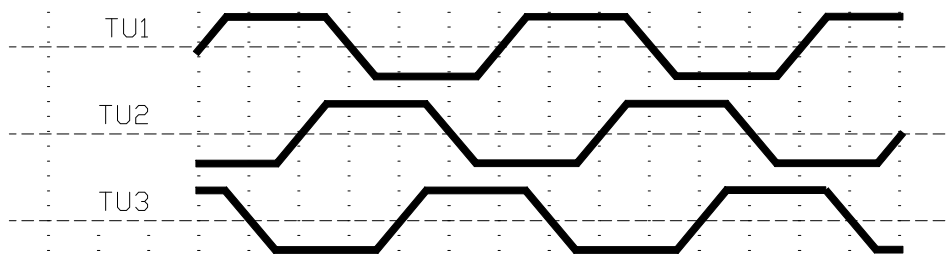

Motor voltage
 Motorspannung

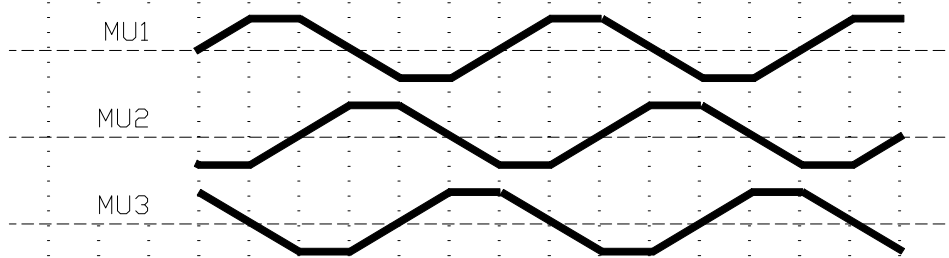

Phase current
 Phasenstrom

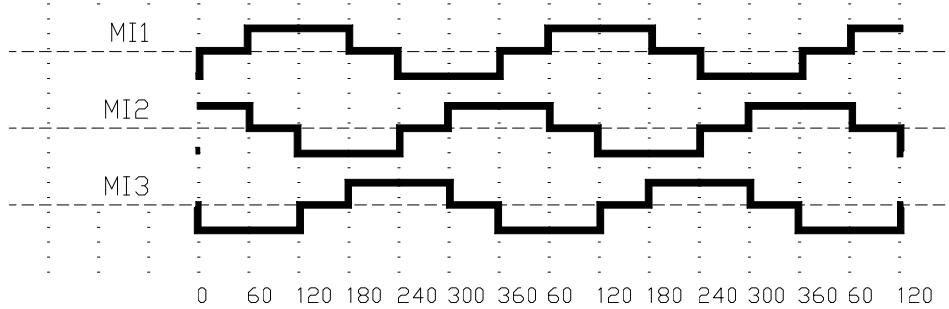

Encoder signals

Guarantee

UNITEK guarantees that the device is free from material and production defects. Test results are recorded and archived with the serial number.

The guarantee time begins from the time the device is shipped, and lasts one year. Unitek undertakes no guarantee for devices which have been modified for special applications.

During the warranty period, UNITEK will, at its option, either repair or replace products that prove to be defective, this includes guaranteed functional attributes. UNITEK specifically disclaims the implied warranties or merchantability and fitness for a particular purpose. For warranty service or repair, this product must be returned to a service facility designated by UNITEK.

For products returned to UNITEK for warranty service, the Buyer shall prepay shipping charges to UNITEK and UNITEK shall pay shipping charges to return the product to the Buyer.

However, the Buyer shall pay all shipping charges, duties, and taxes for products returned to UNITEK from another country.

The foregoing warranty shall not apply to defects resulting from:

- * improper or inadequate repairs effected by the Buyer or a third party,
- * non-observance of the manual which is included in all consignments,
- * non-observance of the electrical standards and regulations
- * improper maintenance
- * acts of nature

All further claims on transformation, diminution, and replacement of any kind of damage, especially damage, which does not affect the UNITEK device, cannot be considered. Follow-on damage within the machine or system, which may arise due to malfunction or defect in the device cannot be claimed.

This limitation does not affect the product liability laws as applied in the place of manufacture (i. e. Germany).

UNITEK reserves the right to change any information included in this MANUAL.

All connection circuitry described is meant for general information purposes and is not mandatory.

The local legal regulations, and those of the Standards Authorities have to be adhered to. UNITEK does not assume any liability, expressively or inherently, for the information contained in this MANUAL, for the functioning of the device or its suitability for any specific application.

All rights are reserved.

Copying, modifying and translations lie outside UNITEK's liability and thus are not prohibited. UNITEK's products are not authorised for use as critical components in the life support devices or systems without express written approval.

The onus is on the reader to verify that the information here is current.

Customer

Machine No.

Device

Serial No

Supply voltage [V=,V~].

Inputs

Enable	contact ?	voltage [V=]
Command value 1	type	voltage [V=]
Command value 2 additional	type	voltage [V=]
Current command value I _{max1} external		voltage [V=]
Current command value I _{max2} external		voltage [V=]

Speed controller settings

Actual value - rough adjustment
DC tachometer S9 Position

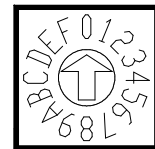

Switches

P-term S4 Position
I-term S5 Position

Potentiometers

Speed	n _{max}	P4	Position
Peak current	I _{max1}	P5	Position
Peak current	I _{max2}	P6	Position
Continuous current	I _D	P7	Position
Integrator	INT	P1	Position
Amplification	XP	P3	Position
Offset	Offset	P8	Position

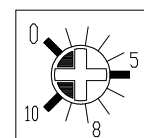
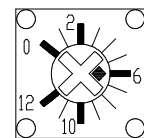

Jumper (Plug-in bridges) soldered jumpers

plugged-in no.
open no.

Adjustments - power section

Current control loop amplification

Resistances - current control loop (kΩ)

Measured data

Motor voltage	max.	[V~] 3x
Motor current	peak	[A~] 3x
Motor current	continuous	[A~] 3x
DC tacho voltage	max.	[V=]
Acceleration		[V/ms]
Braking		[V/ms]

Motor Data

Manufacturer	
Type	Serial number
Motor voltage [V~]	Motor current [[A~]
Brake [V]	Fan [V]

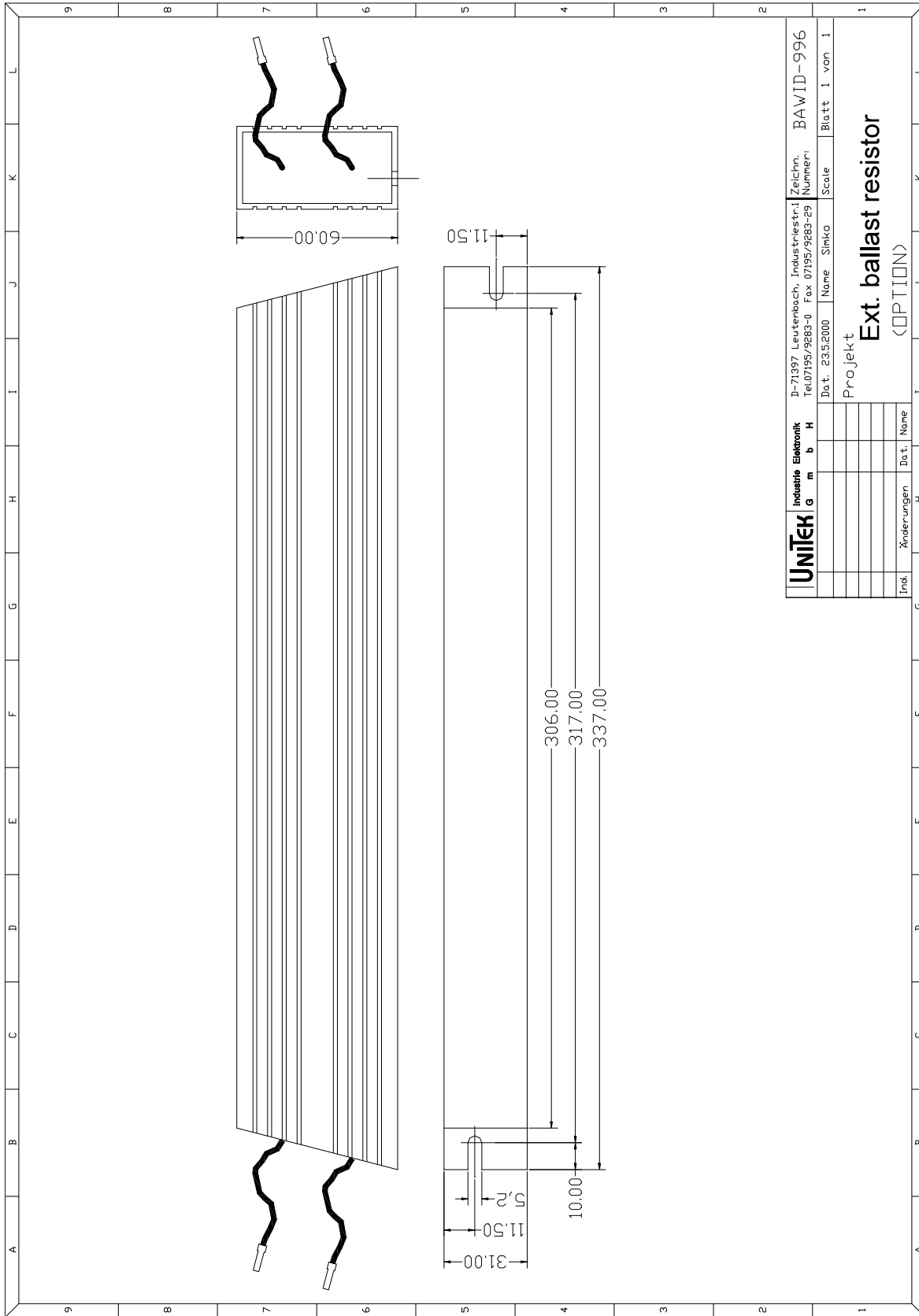

Transistor Servo-Drive TVD6-200bl, TVD6.2-400bl

Encoder connection for AC-Synchro-Servo-Motors with Rotor position encoder and bl-Tachometer.

UNITEK-Motor connection

TV D3	TV D6	MODULA
X3	X3	X10
3	7	M1
2	8	M2
1	9	M3

UNITEK-
Electronics connection
Rotor position encoder + bl-Tachometer

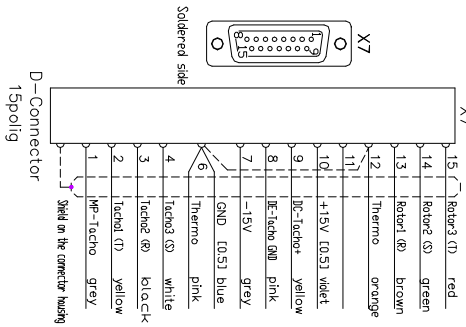

without Thermo
Bridge X7/12
to X7/6

MOTOR	ABB GC/LC	AEG-MT-Motors	BAUMÜLLER DS-Motors	EMDD EC-Motors	SCHABMÜLLER SDS	SIEMENS 1FT-Motors	STÖBER EC-Motors
Terminal-Box							
MOTOR-connector							
Encoder cable shielded	12x 0.25 oder 10x 0.25+2x 0.5	12x 0.25	12x 0.25	12x 0.25	12x 0.25	12x 0.25	12x 0.25
Encoder connector soldered side of ...							
Network Rn1/RN2 by 3000min-1	remove	10kDhm	22kDhm	33kDhm	33kDhm	47kDhm	10kDhm

UNITEK Industri Elektronik
 D-71397 Leutenbach, Industriestrasse 1 | Telefon: 07149 11330
 Tel: 07195/9883-0 Fax: 07195/9883-29 | E-Mail: info@unitek.de
 Projekt: Anschlussplanübersicht TVD3, TVD6 und Modula mit x ... Motoren